

Spiral® SST and STT Installation Manual

Rytec installation safety information

The meaning of signal words

Summary



Technical content produced by Rytec includes safety information which must be read, understood and obeyed to reduce the risk of death, personal injury or equipment damage. This information is boxed to set it apart from other text. The boxed text identifies the nature of the hazard and appropriate steps to avoid it.

The safety alert symbol identifies a situation that can result in personal injury. The accompanying signal word indicates the likelihood and potential severity of the injury. The meaning of the signal words is as follows:

	⚠ WARNING
	Warning indicates a hazardous situation that, if not avoided, could result in death or serious injury.
	⚠ CAUTION
	Caution indicates a hazardous situation that, if not avoided, could result in minor or moderate injury.

Safety icons used in this manual



Shock hazard



Fall hazard



Crush hazard



Cut hazard



Forklift

Installation safety

- **Do not install any Rytec product until** you have read and understood the safety information and instructions. Make sure all applicable regulations are observed and obeyed at all times.
- **Observe these precautions** while installing the door:
 - Only trained, qualified and authorized individuals are to install the door and the control system.
 - The installation site comprises the physical area required to safely uncrate, stage and install the door.
 - Make sure all personnel at the installation site have been informed of the date, time and location of the installation.
 - Make sure there is no pedestrian or vehicular traffic within the installation site for the duration of the installation.
 - Make sure you have and use all required Personal Protective Equipment.
 - Make sure you have adequate personnel and equipment to safely perform all lifts.
 - Make sure you have been informed of any hazardous conditions that exist within the installation site.
 - Make sure the installation site is kept clear of obstructions and debris and that the floor is dry.
 - Make sure you are aware of the location of all power lines, piping and HVAC systems within the installation site.
 - Make sure all accessories installed with the door are approved by the manufacturer.

Other icons used in this manual



Indicates instructions which, if not followed, could result in **damage to the door** or **voiding of the warranty**.



Indicates **best practice**. This is how Rytec Technical Support does the job.

Requirements – Staffing

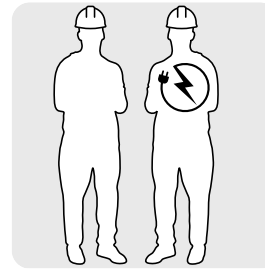

Two installers

A licensed electrician is recommended for making all electrical connections

Electrician's responsibilities

Refer to the Rytec System 4® Drive & Control Installation & Owner's Manual for a complete list of the electrician's responsibilities.

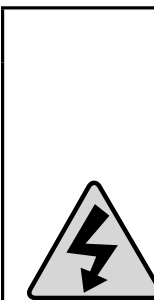

⚠ WARNING

Electrical work must meet all applicable local, state and national codes.

Failure to wire the door correctly can cause shock, burns or death to the people who install, use or service the door.

Failure to comply also voids the warranty for the door.

Requirements – Lifts

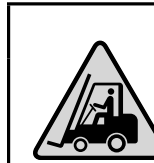

⚠ WARNING

A forklift is mandatory for the safe and proper installation of this door.

- **Forklift** that meets the following specifications:

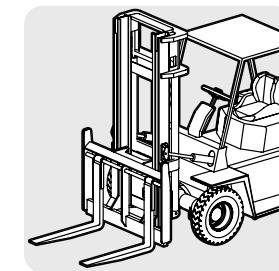

- Minimum 4,000-pound lift capacity
- Minimum height ability: door height + 12"
- 48"-wide fork
- Side shift capability

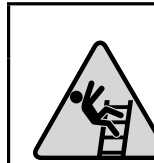

⚠ WARNING

Follow all safety instructions on all lifts and ladders used for this installation.

- **Scissor lift** that meets the following specifications:

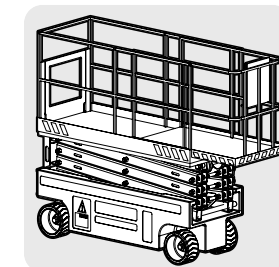

- Can hold both installers
- Minimum height ability: door height

- **Alternatively, two ladders** of sufficient height to safely access the door head assembly

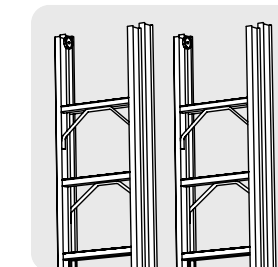

Terms used by Rytec to describe the parts of the door

This illustration shows the terms used by Rytec technical support to refer to the major components of your door.

Using these terms helps technical support provide assistance as quickly as possible.

Table of Contents

- Rytec® installation safety information 1
- The meaning of signal words 1
- Safety icons used in this manual 1
- Installation safety 1
- Requirements – Staffing 1
- Electrician’s responsibilities. 1
- Requirements – Site Conditions 1
- Requirements – Lifts 1
- Other icons used in this manual. 1
- Terms used by Rytec to describe the parts of the door 2
- How to uncrate the door and inspect the installation site 3
- How to prep the head assembly. 5
- How to prep the side columns. 7
- How to center the door in the door opening. 7
- Plumb, level, square: how to position the door correctly as you install the side columns 8
- How to install the head assembly 11
- How to remove the cradle 12
- How to raise the vertical guide tracks into place. 12
- How to run the drive side cables for Pathwatch and light curtain 13
- How to run the non-drive side cables for Pathwatch and light curtain 13
- How to install the springs 15
- How to install the secondary drive belt 17
- How to install the corner brackets, wireless antenna and (optional) bottom hood spreader 18
- How to connect the brake release cable to the brake release lever. 20
- (optional) How to install the bottom hood cover. 21
- (optional) How to install the slanted top hood cover 22
- How to install the System 4 controller and wire the door. 24
- Before powering up the door 28
- How to set limits and test the door 28
- What to test after powering up the door 29
- How to finish testing the door and the safety features 33
- How to complete the installation 34

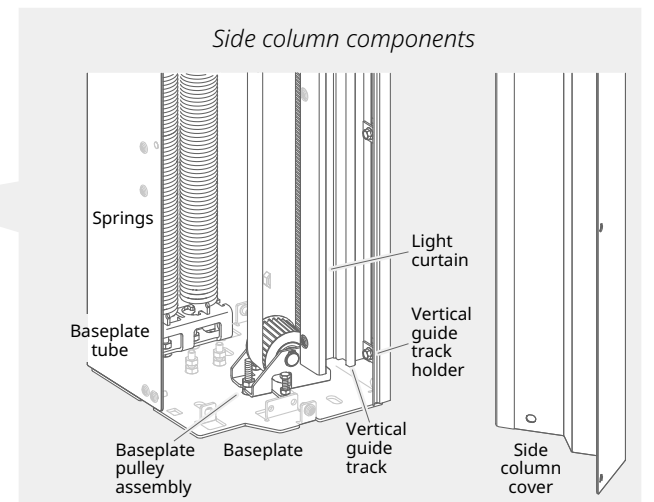
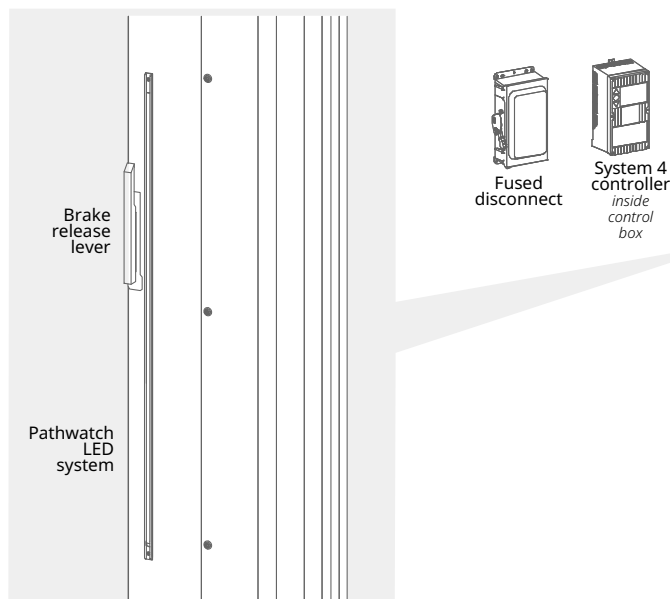
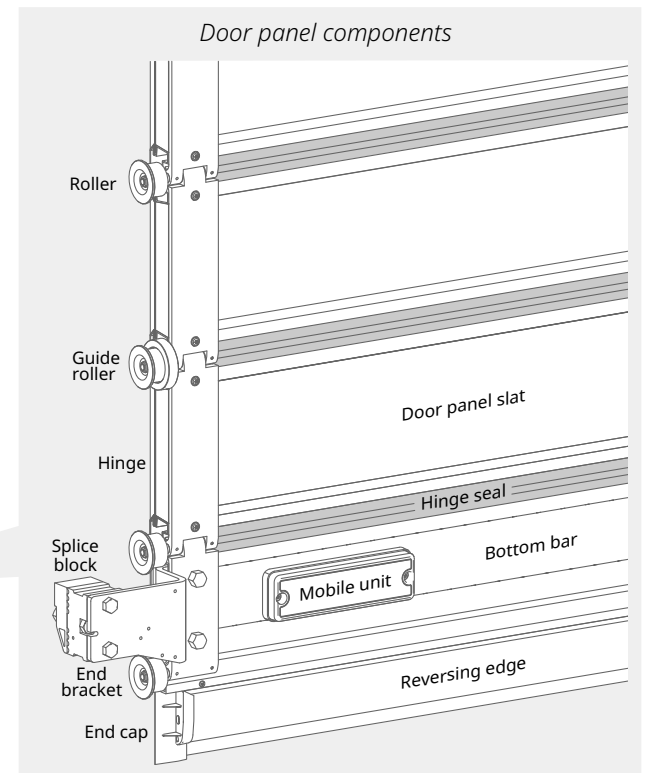
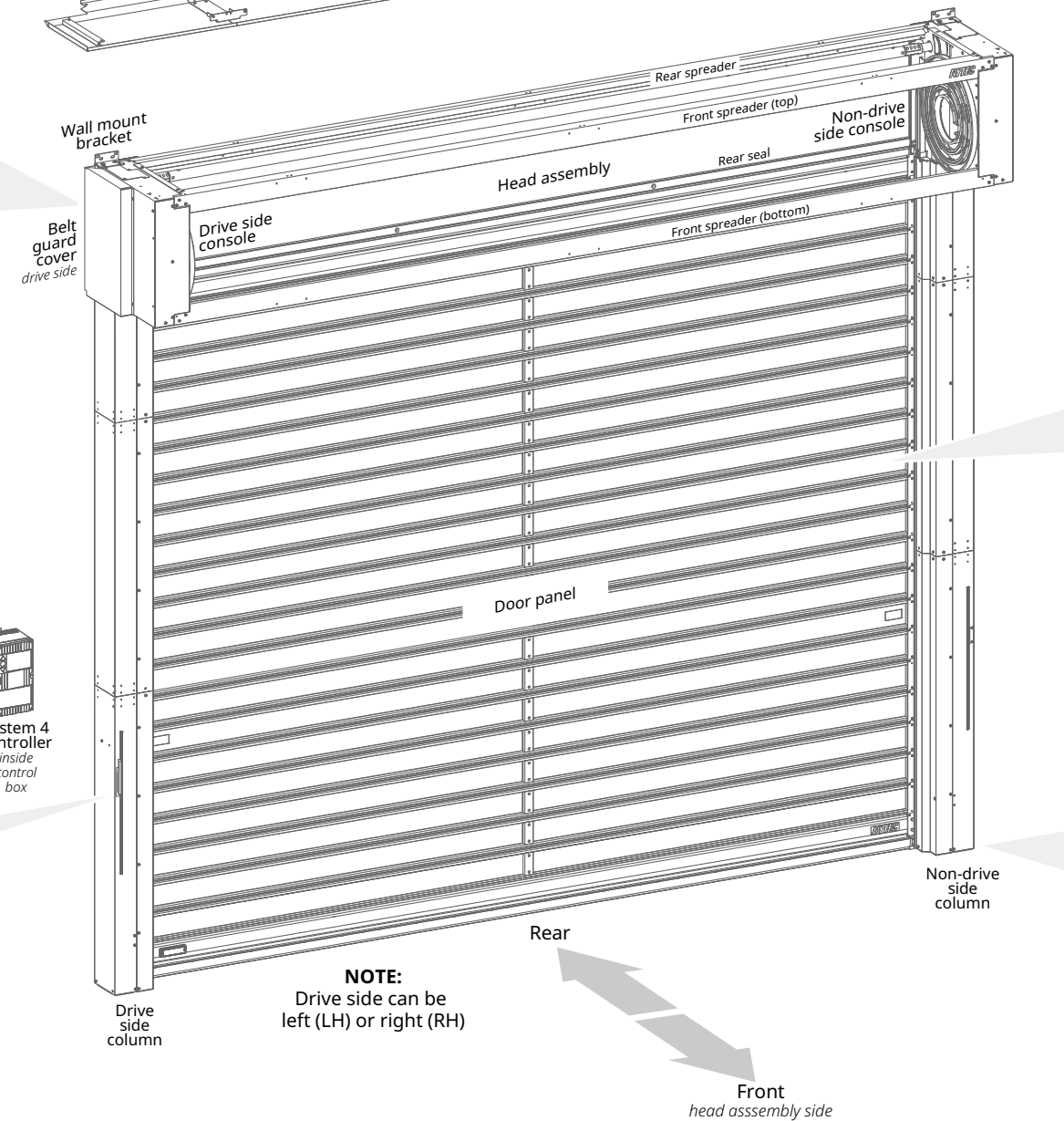
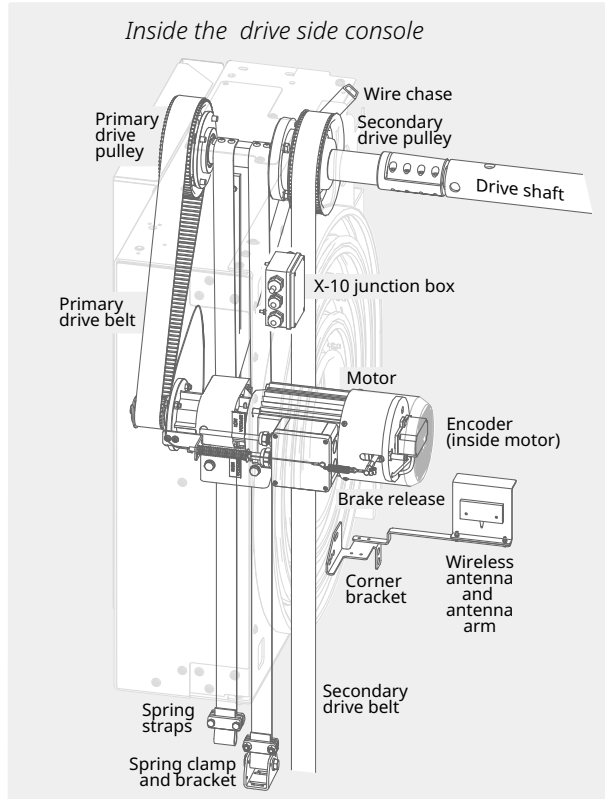
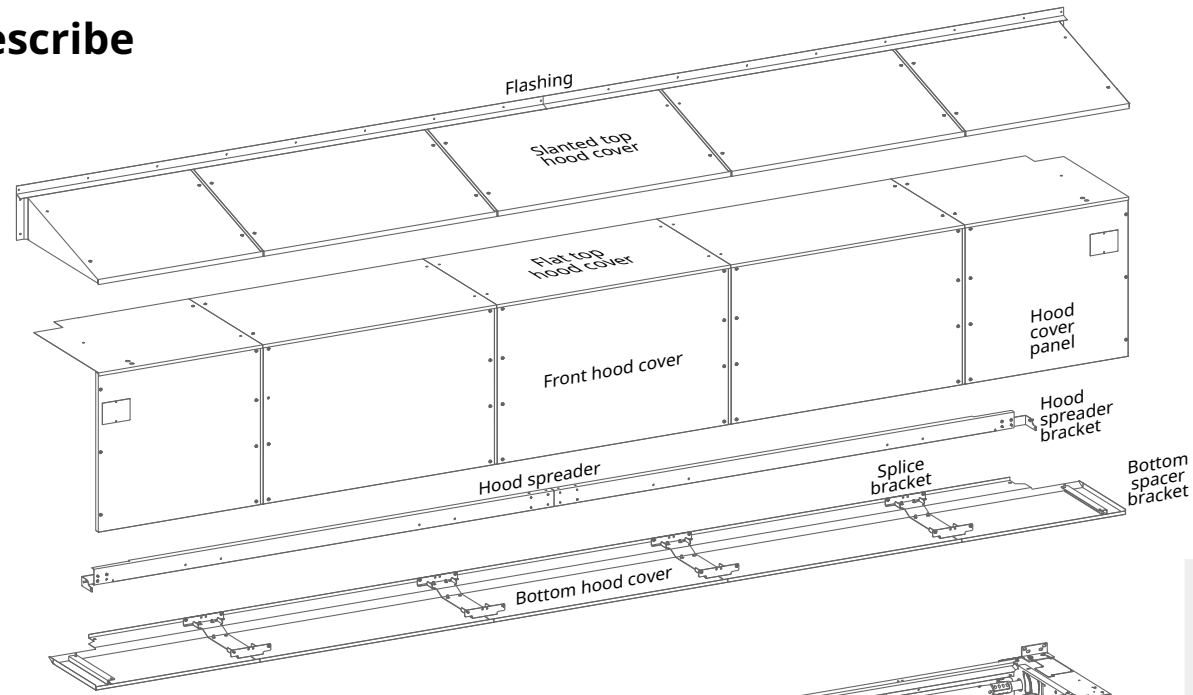

Spiral® Installation Manual for SST (Solid Panel) and STT (Full Vision Panel) Models

Call **800-628-1909**

or email helpdesk@rytecdors.com

if you have any questions during this installation. See previous page for list of Rytec terms for the parts of the door.

How to uncrate the door and inspect the installation site

IMPORTANT

Spirals ship in two crates (three if there is a slanted hood cover).

Each set of crates is marked with the unique serial number for the door ① and the number of crates used for the door ②.

All parts for the door are in these crates.

If more than one door is to be installed, treat each set of crates as a separate installation.

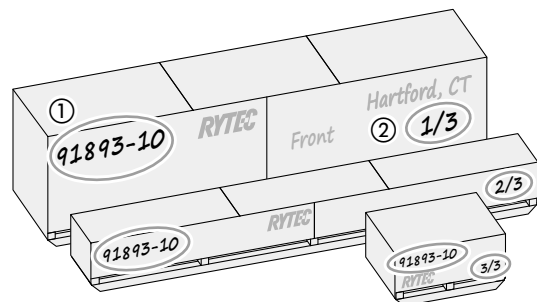

Mixing parts from different doors voids the warranty for all doors in the installation.

1 Remove all top panels.



Pry bar

INSIDER'S TIP

Panels are made of fiberboard that shreds easily, and are secured with many nails.

Slide the pry bar along the edge, prying gently every six inches, to remove the panel in one piece.



2 Check the crates. Make sure all serial numbers match the number on the crate and all visible parts have no shipping damage.

Drive belt guard cover: indicates drive side. May be left (LH) or right (RH). LH is used for this manual.

Flat top hood cover (optional): preinstalled. Must be removed to access the head assembly components, then reinstalled.

Front hood cover (optional): preinstalled. Some panels must be removed, then reinstalled.

Head assembly: check the serial number on the label (inside top, non-drive side).



System 4 controller box: check the serial number on side of box.

IMPORTANT

Small parts box(es): check the serial number on side of box. There may be two boxes.

Open box, remove the red documents envelope, then open the envelope and get the object list (also called the cut sheet). Check serial numbers on both.

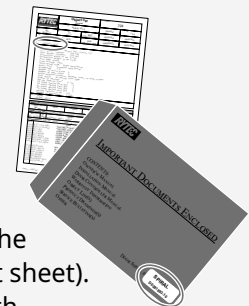

SMALL PARTS

Parts and hardware that you find in the box(es) will be called out in this manual as they are needed.

Slanted top hood cover (optional): third crate holds panels and brackets. Number varies based on size of door.

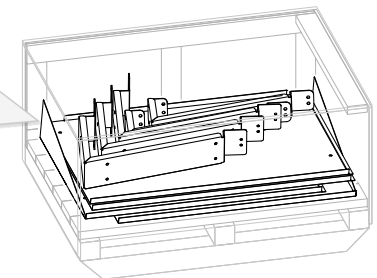

Bottom hood cover (optional): panels are crated in front of head assembly, and brackets are crated under the lifting cradle.

Springs: number varies from one to twelve based on size of door.

Side columns: check the serial number on the label.



3 Check your tools. Make sure you have all tools and supplies for the installation.

Tools you need



Pry bar and mallet or reciprocating saw



Crowbar



Cutting pliers



Utility knife

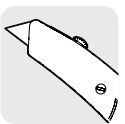

Wire stripper

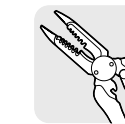

Precision screwdriver



Flat screwdriver



#2 Phillips screwdriver

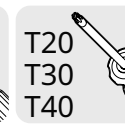

T20 Torx screwdriver

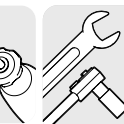

10mm 13mm 17mm Socket or open wrench



7mm 10mm 13mm (2) Sockets or wrenches needed

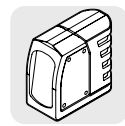

Laser level

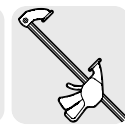

(2) Bar clamps

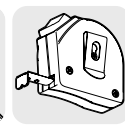

Measuring tape

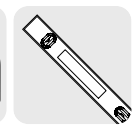

Spirit level



Carpenter's square

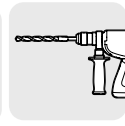

Anchoring tools

You also provide



Anchoring hardware

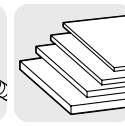

Shims

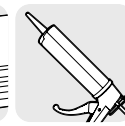

Caulk

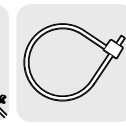

Cable ties

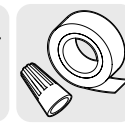

Electrical tape and wire nuts

4 Check the measurements. Make sure the door will fit in the installation site.

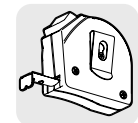

Tape measure

Object list		Material number
Original		
Description lists if door is small (-L, -L/R), large (-S, -S/R) or extra large (-US, -US/R).		
MRP controller	Production scheduler	Order type
500	T7	ZP02
B5 ZMAT	Tier 7	RYTEC MTO C
Status	Plant	
REL MSPT PRT PRC SETC	2000	
Serial number		
D0091893-010		
Configuration		
DOOR MODEL NAME Spiral Full Vision "L"		
Door Width (Inches)	144-094	144-1/16
Door Height (Inches)	128-346	128-3/8
Production Width in mm	3,660	
Production Height in mm	3,260	
Door head size B		
Line Voltage	460V	
motor mount side	Right Hand Motor	
Motor Duty	Standard Duty Motor	
Horsepower	2.0	
Number of solid	ts 0	

Write on object list:
 Width to center = 1/2 ①
 Total width = ③
 Total height = ② + ④

Description lists if drive side is left hand (LH) or right hand (RH).

IMPORTANT

Spirals are built to metric specifications to a very tight spec. Round the **Door Width** and the **Door Height** to nearest 1/16 inch.

Decimal	.063	.125	.188	.250	.313	.375	.438	.500
Fraction	1/16	1/8	3/16	1/4	5/16	3/8	7/16	1/2
Decimal	.563	.625	.688	.750	.813	.875	.938	
Fraction	9/16	5/8	11/16	3/4	13/16	7/8	15/16	

1. **Locate the Door Width ① and Door Height ② on the object list.**
Round the numbers to nearest 1/16 inch.
2. **Measure the door opening** to make sure the width and height match the numbers on the object list.
3. **Calculate the width to center:** divide the Door Width ① by 2.
Write this number on the object list. **Use it** when you center the door.
4. **Find the total width of the door:** measure the width of the head assembly ③ in the crate.
Write this number on the object list.
5. **Calculate the total height of the door:**
 - Start with the Door Height ②.
 - Measure the height of the head assembly ④ in the crate. Add this to ②.
 - Add 13 inches (13") to account for the height of the forklift backrest or an optional slanted hood.**Write this number** on the object list.
6. **Make sure there is enough space to lift the door:** make sure the site has space for the total width and the total height you calculated.

Call Rytec technical support at 800-628-1909 or email helpdesk@rytecdoors.com if you have any questions about the measurements at the site.

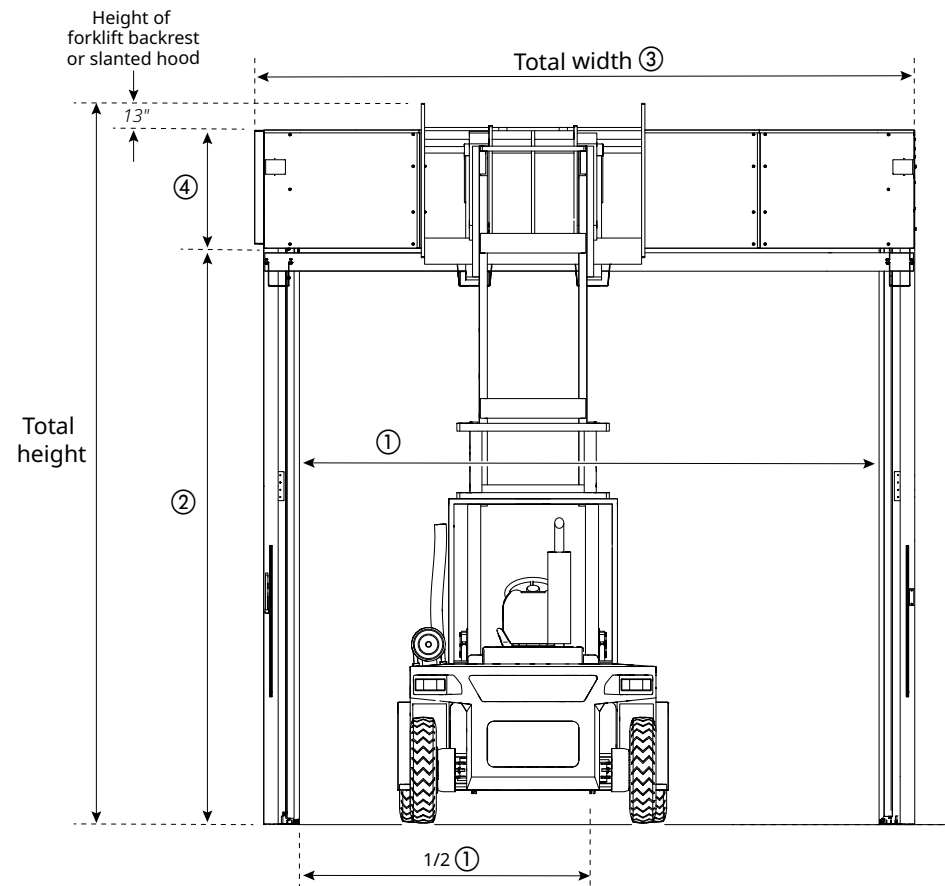
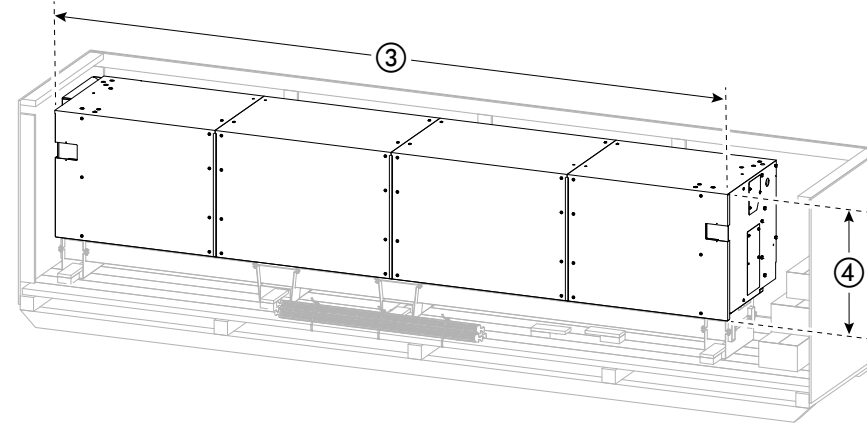

5 If all checks are good, finish uncrating the door. Starting at the center, remove the crossbars, then remove the front panel.

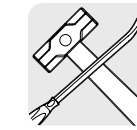

Mallet and pry bar or

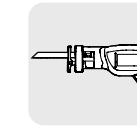

Reciprocating saw

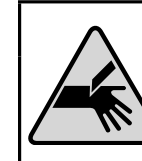

CAUTION

Flatten exposed nails as you go. Keep hands clear while striking or cutting.

① Strike across the crossbar to loosen nails. Do not strike down.

② Strike the side panel to expose nails.

③ Pry up to remove crossbar.

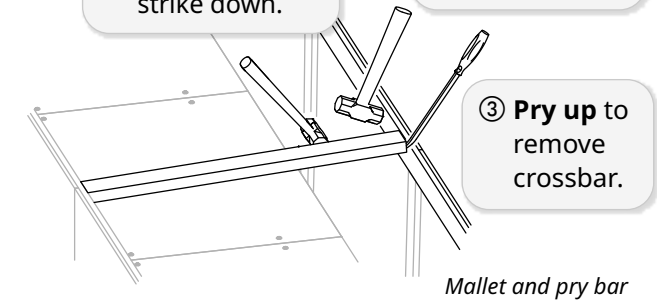

Mallet and pry bar

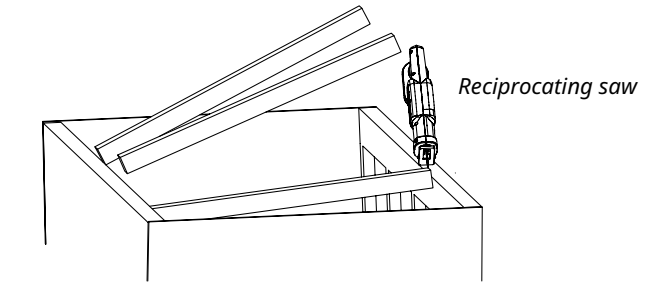

Reciprocating saw

End panels are nailed into the side panel. Strike crossbar and pry end panel to loosen nails. Pull side panel free from sides, then pull down to remove.

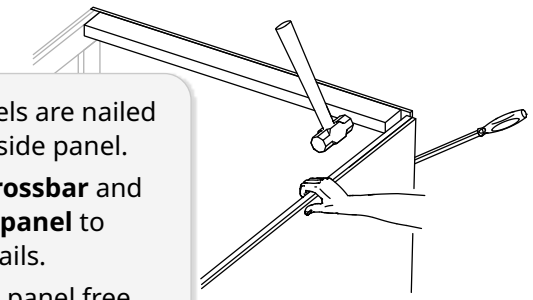

Mallet and pry bar

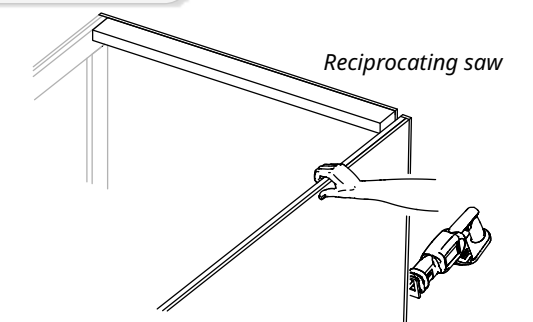

Reciprocating saw

How to prep the head assembly

- 1 Remove** springs, blocks and (optional) hood cover panels for clear access.
Use a forklift to move the head assembly to an open space.

INSIDER'S TIP

After the head assembly is removed, **use the crate** to stage parts until they are needed.

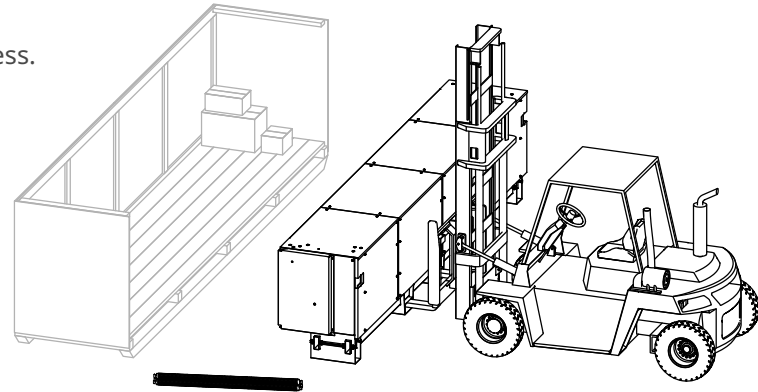

- 2 Locate and remove** the rear seal (rear spreader).
 On smaller (-L and -L/R) doors, it is tied to the top rear spreader.
 On larger (-S and -S/R) doors, it is tied to the back of the lifting cradle.

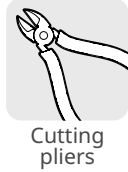

Cutting pliers

If the door has a **slanted top hood cover**, the flashing will also be tied to the cradle.

If the door has a **bottom hood cover**, the bottom hood spreader will also be tied to the cradle.

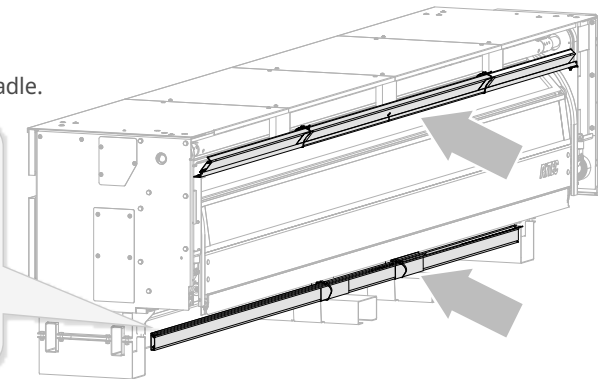

Before you begin: differences between the -US -US/R (extra large) doors and the -S -S/R (large) doors

Extra large -S and -S/R doors are designated as -US and -US/R. **Note these differences:**

- The **motor and encoder** are located **outside** of the head assembly ①.
- The motor has an external cover ②. **Remove** this instead of the drive side console cover.
- There are **six preinstalled side column screws** and washers on each side of the door.

On the drive side, two of these screws ③ will require a **wobble or swivel extension** to tighten when the head assembly is installed.

- The encoder cable is routed differently from other Spirals. This will be shown on page 18.

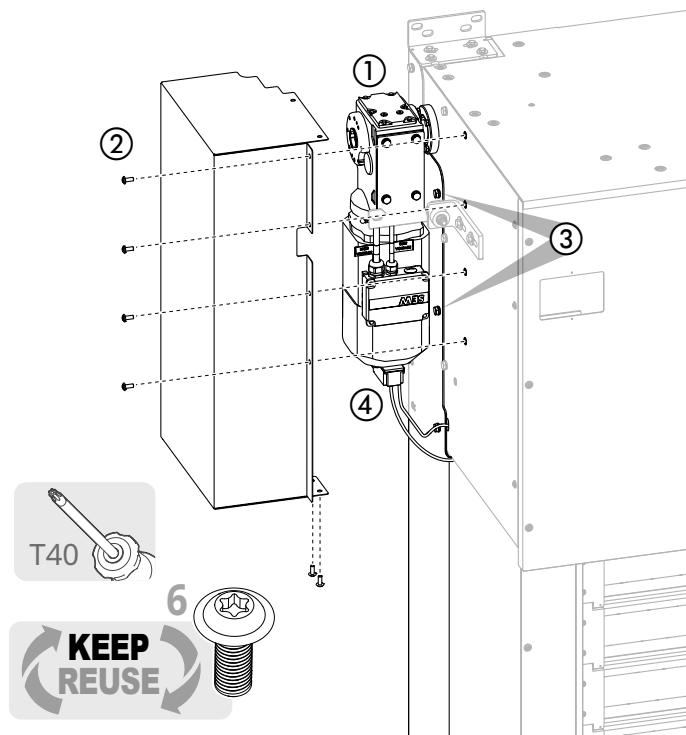

- 3 Remove** the belt guard cover.

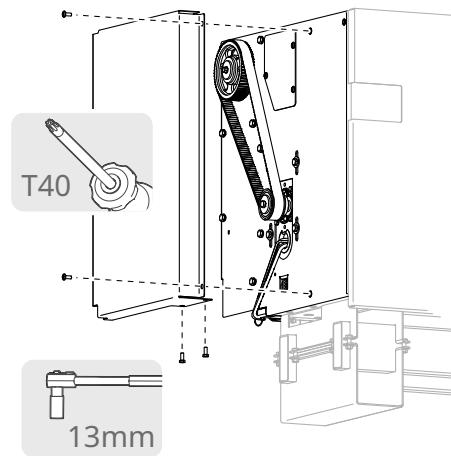

Note: on -S and -S/R doors, all hardware requires a T40 torx screwdriver.



- 4**

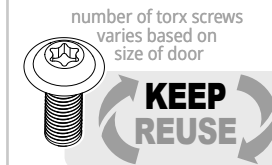
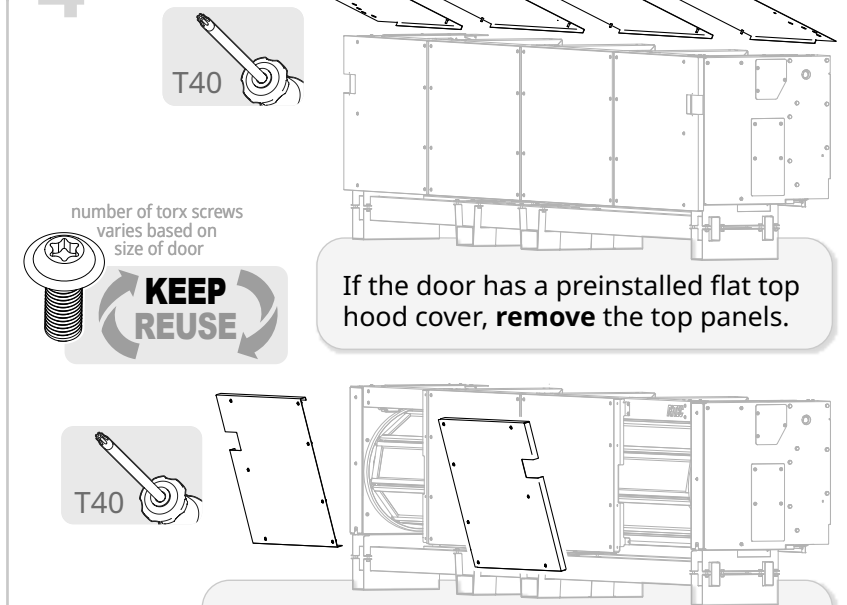

If the door has a preinstalled flat top hood cover, **remove** the top panels.



Note: -S and -S/R doors have both top and bottom front spreaders.

If the door has a preinstalled front hood cover, **remove** the panels in front of the side consoles. **For -L and -L/R doors with bottom hood covers**, remove all of the front panels.

Note: number of panels varies based on size of door.

- 5 Remove** the console cover and spacer bracket. **Do this** on both sides of the head assembly.

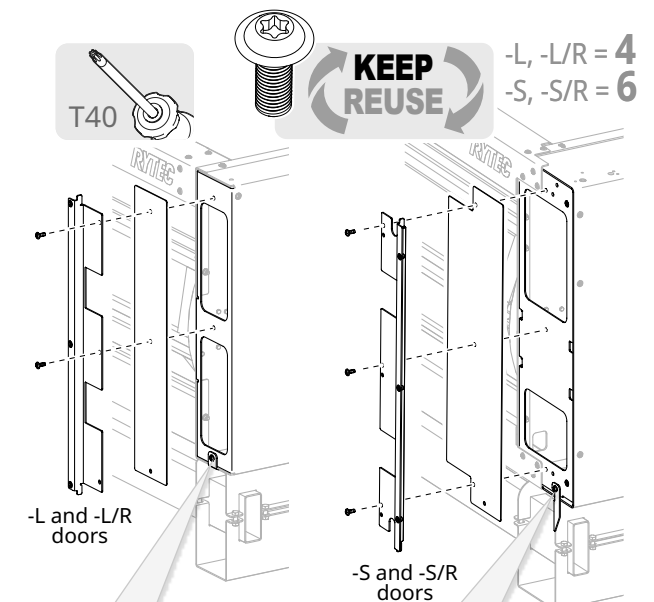

IMPORTANT The screw that secures the mounting cradle is preinstalled behind the cover and bracket. **Do not remove it** until the head assembly has been lifted into place.

6 **Protect your cables!** On the drive side, **reach** into the back of the console and place the four cables inside on top of the head assembly. **Make sure** cables are clear of the side columns (non-shaded area). **Leave the pulley and spring strap** in place.

IMPORTANT

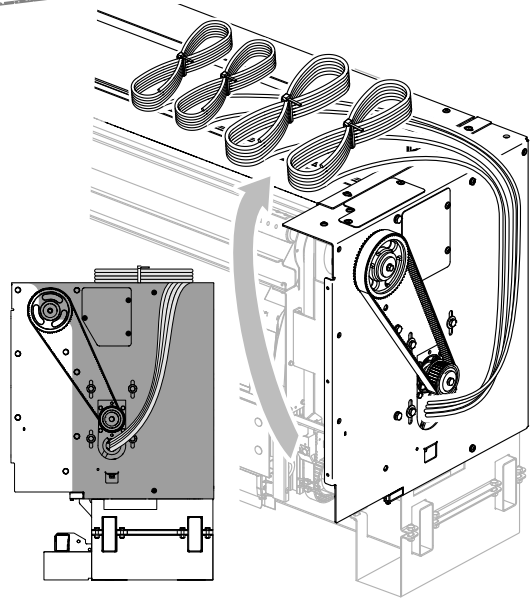

7 **Remove** the five preinstalled side column screws (located in the non-shaded area). **Do this** on both sides of the head assembly.

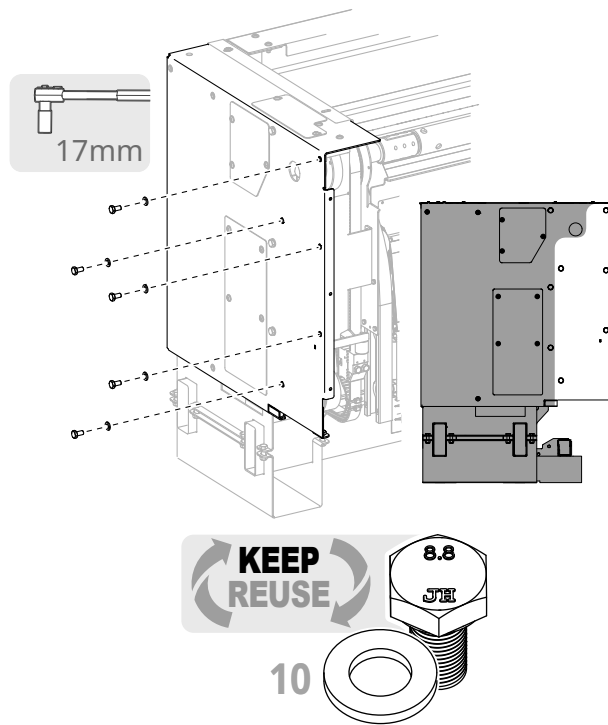

8 **IMPORTANT** **Protect the brake release cable!**

The cable is preinstalled, and can be damaged when the head assembly is raised onto the side columns. This extra step puts it out of harm's way.

Unscrew the retaining nut, cut the cable tie and slide the cable through the hole in the console. **Slide the nut** up the cable and reattach. **Coil the cable** inside the console.

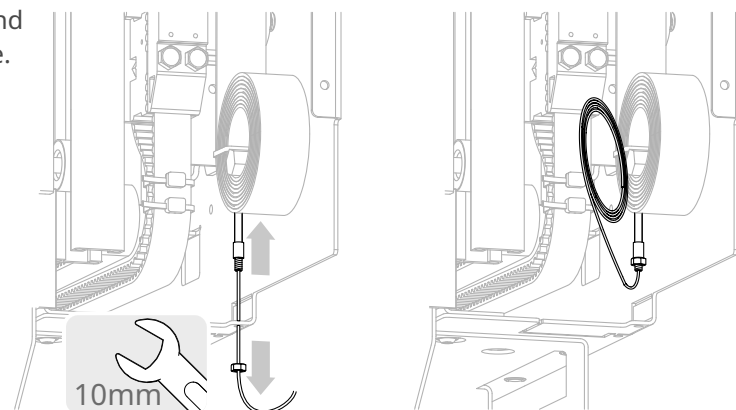

9 **-S and -S/R doors only: look for** the wall mount brackets at the top rear corners of the head assembly. **Remove** the screws and washers and **flip** each bracket so the flange points up. **Line up** bracket with the rear of the head assembly, then **reinstall** the screws and washers.

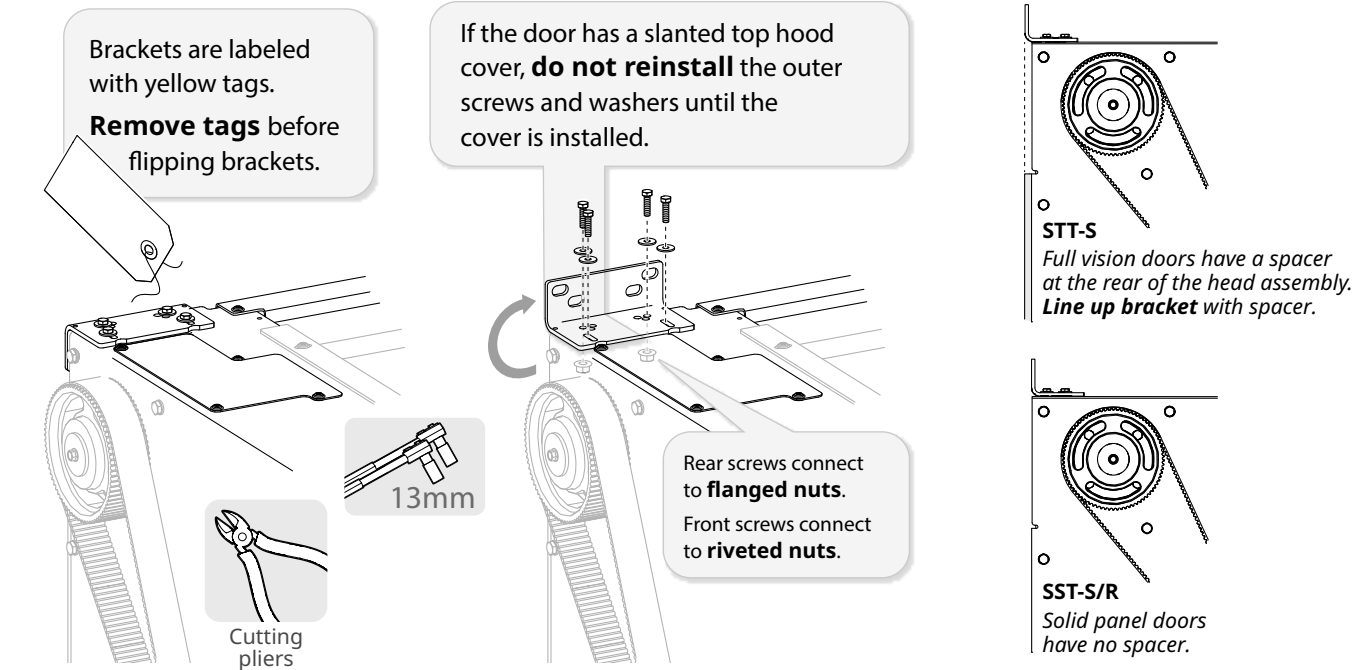

10 Before lifting the head assembly, **clamp both forks** so the fork pockets are secure.



C-clamp (2)

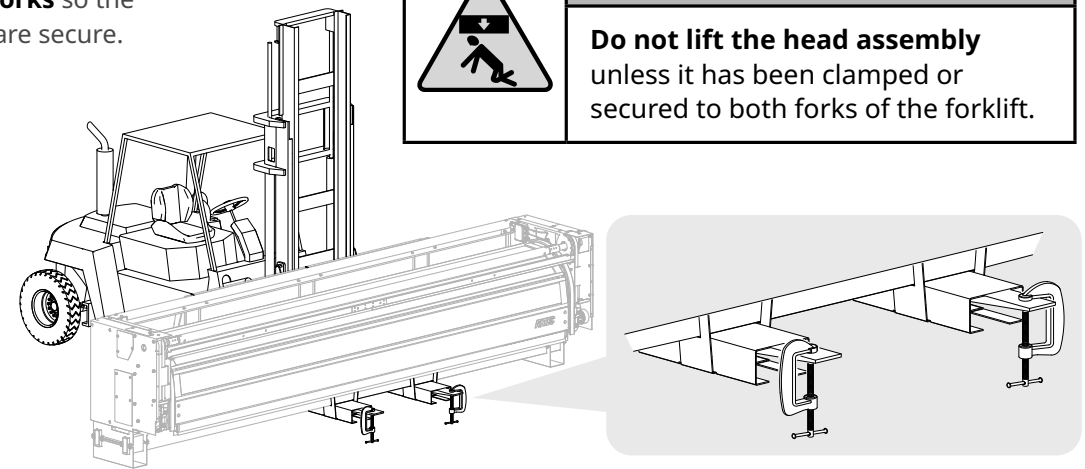

How to prep the side columns

- 1 Remove** the covers on both side columns.
Screws for side column covers run in a vertical line. There is also one screw at the base of the column.

Check all surfaces on side columns and head assembly for protective film. **Remove film.**

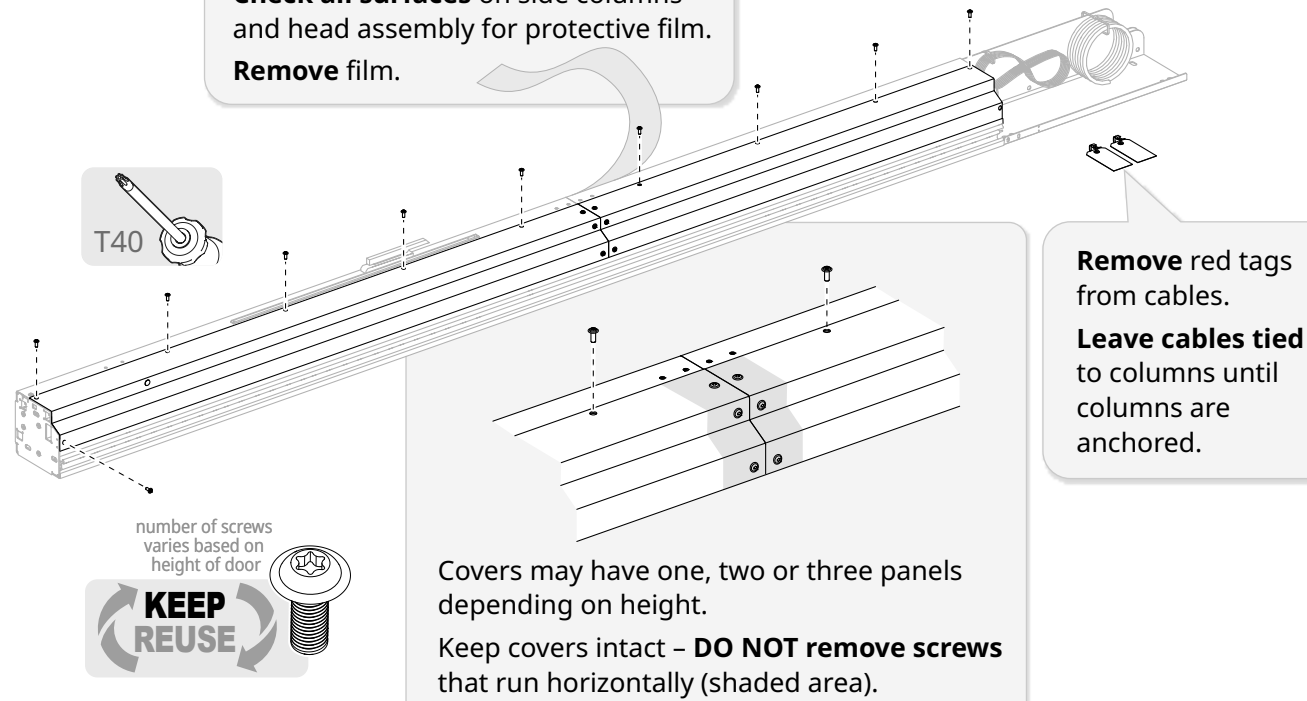

- 2 Make sure** the vertical guide tracks for the door panels are in the fully lowered position.

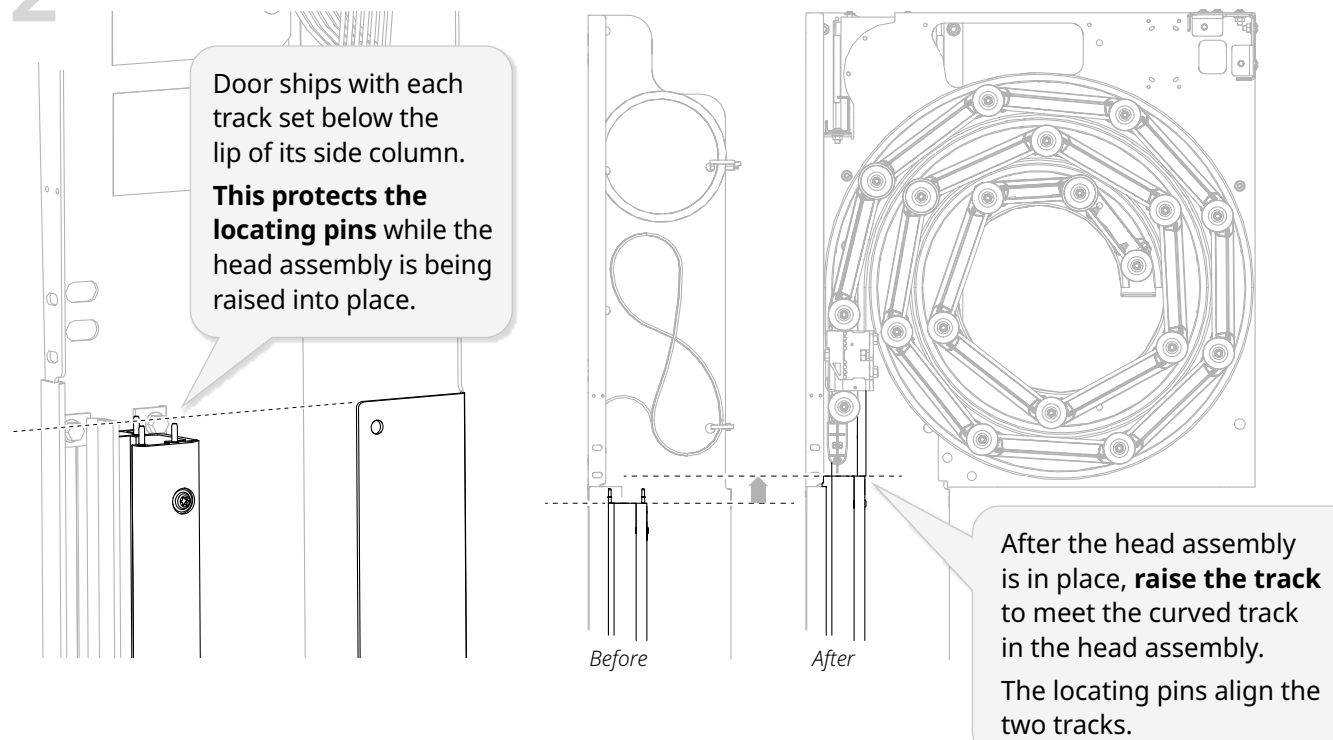

- 3 Loosen** the holders on the vertical guide track. **If necessary**, lower the track.
Do this for both columns.

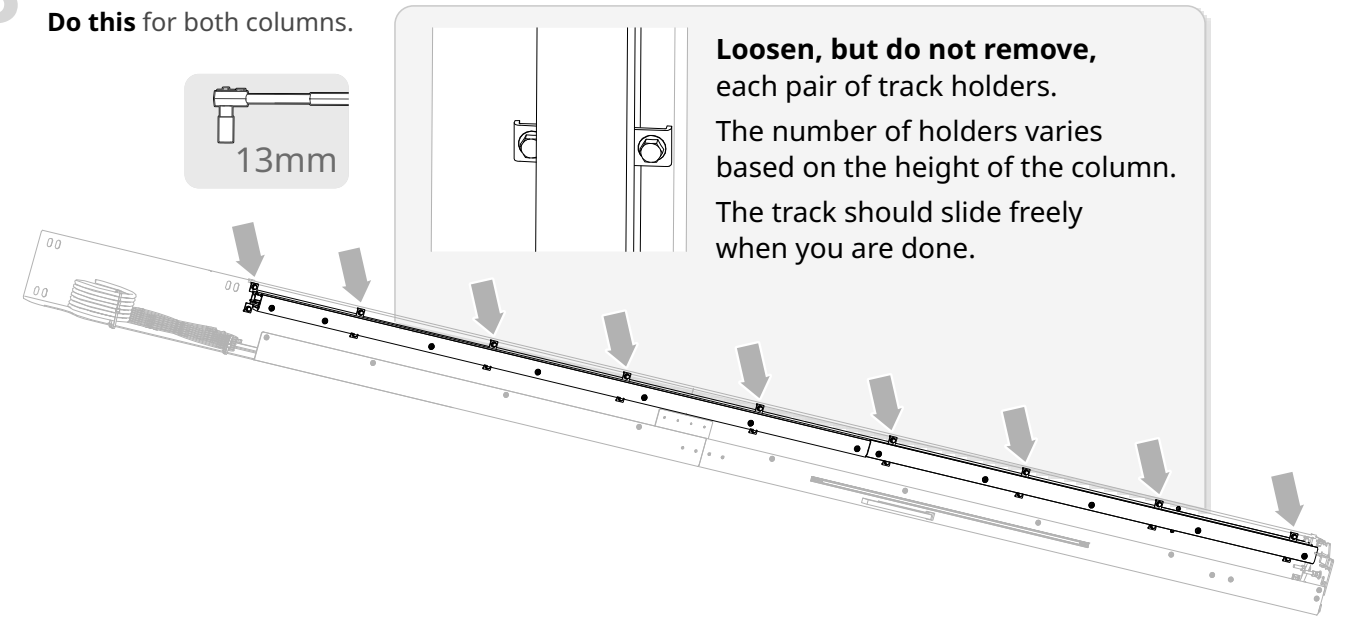

- 4** **13mm** Select one holder at the halfway point of the side column and **hand tighten the screws** to secure the guide track in place. **Do this** for both columns.
The tracks can now be repositioned easily after the side columns are installed, but will not slide while the columns are being lifted into place and leveled.

How to center the door in the door opening

IMPORTANT

Rytec doors are engineered to be centered in the door opening, so follow these steps even if the width of the opening and the production width match exactly.

- 1**
- Measuring tape
- Carpenter's square

Object list		Material number
Original		724
Material description: SPIRAL STT-L		
Order number	20000597	Order quantity: 1 EA
MRP Controller: 500	Production scheduler: T7	Order type: ZP02
B5 ZMAT	Tier 7	RYTEC MTO Order
	Start: 06/03/2019	Finish: 06/05/2019
Plant: REL MSPT PRT PRC SETC	Plant: 2000	Reservation number: 0002425475
	Rytec Corporation -	Creation Date: 05/31/2019
Serial number: D0091893-010		
Configuration		
DOOR MODEL NAME: Spiral Full Vision "L" ①		
Door Width (Inches): 144.094 144 1/16	①	
Door Height (Inches): 128.346 128 3/8		
Production Width in mm: 3		
Production Height in mm: 3		
Door head size: B		
Line Voltage: 460V		
Motor mount side: Right Hand Motor		
Motor Duty: Standard Duty Motor		
Horsepower: 2.0		
Number of solid slats: 0		
Number of vent slats: 0		
Brake Release Location: Release lever on side column		
Hood style: No spiral hood type		
Number of Springs: 4		
Spring Tension (lbs): 4.724		
Oil (Other optional part): 0		
Oil (Other optional part): 0		

Width to center = 1/2 ①

1: Measure the width of the door opening (w) and find the halfway point ($1/2 w$). **Mark** the centerline there.

- 2: Use** the width to center from the object list ($1/2$ ①). **Starting at the centerline**, measure and mark the reference line for the first column.

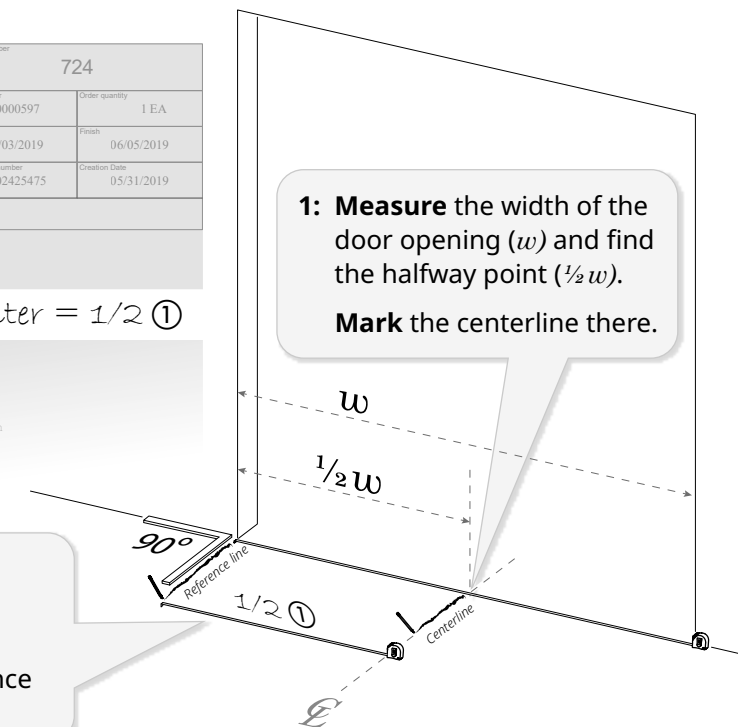

Plumb, level, square: how to position the door correctly as you install the side columns

IMPORTANT

Call Rytec technical support at 800-628-1909 immediately and stop the installation if you are not able to correctly position the door.

Before you begin: where to find the anchor points on the Spiral side columns

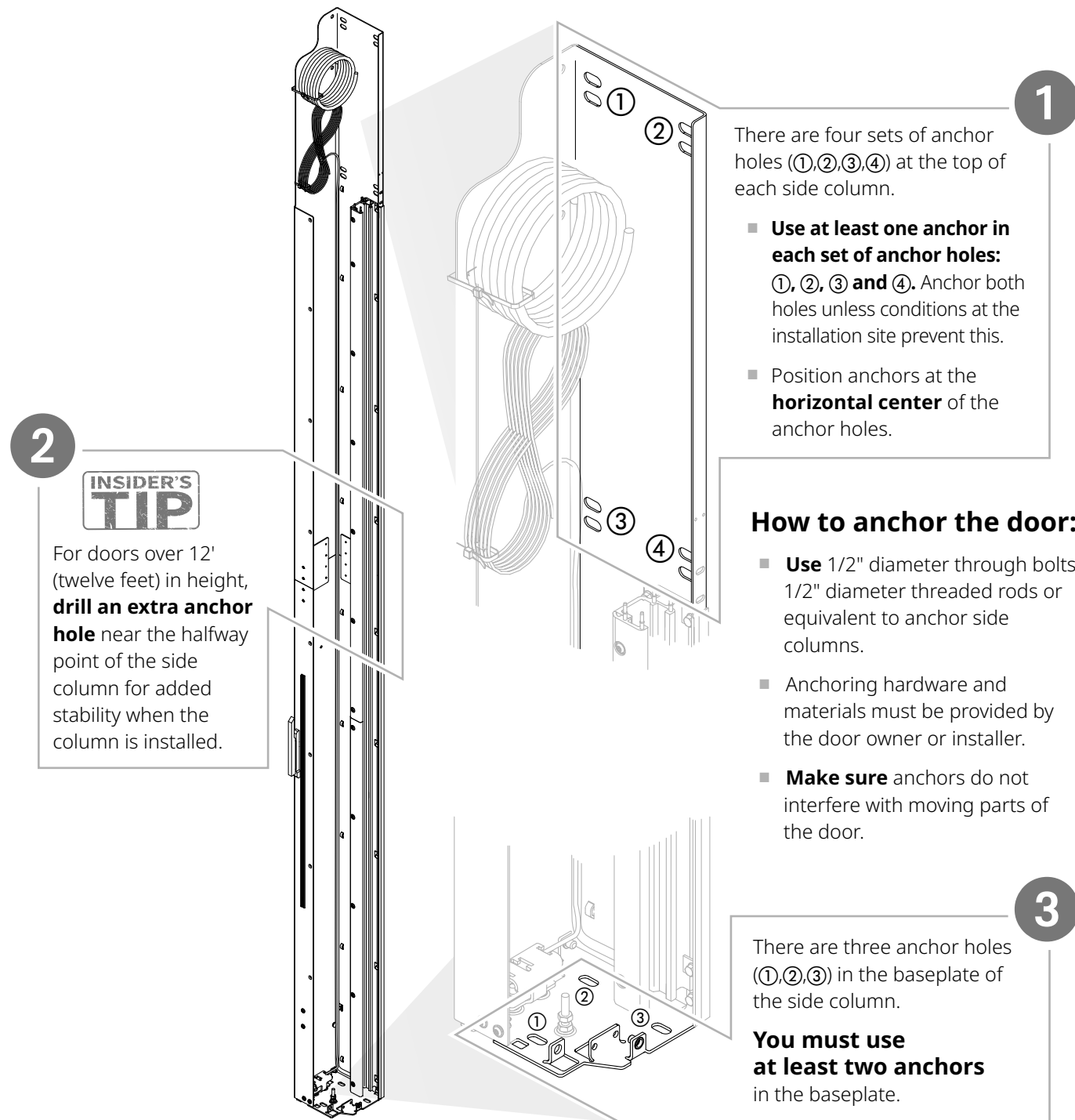

Step 1: Plumb and level the site, then install and plumb the side columns

1 Plumb the door opening. **If the wall is not plumb**, or there is bowing or an obstruction in the wall, shim the columns.

IMPORTANT

To prevent column from bowing, shim as needed **at each anchor point**.

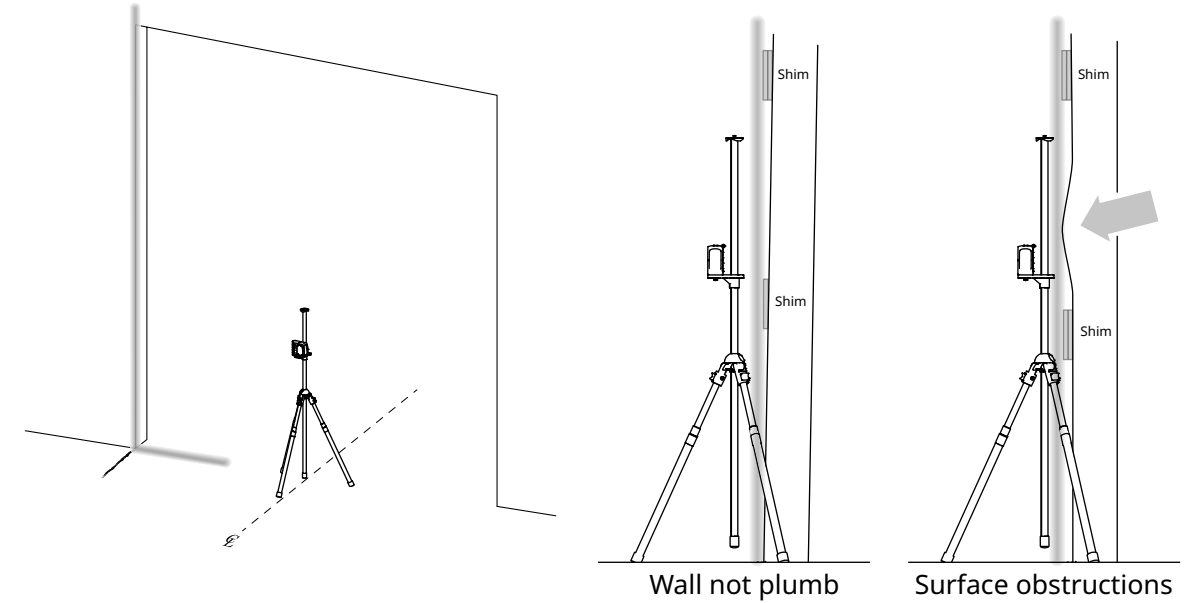
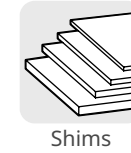

2 Level the floor.

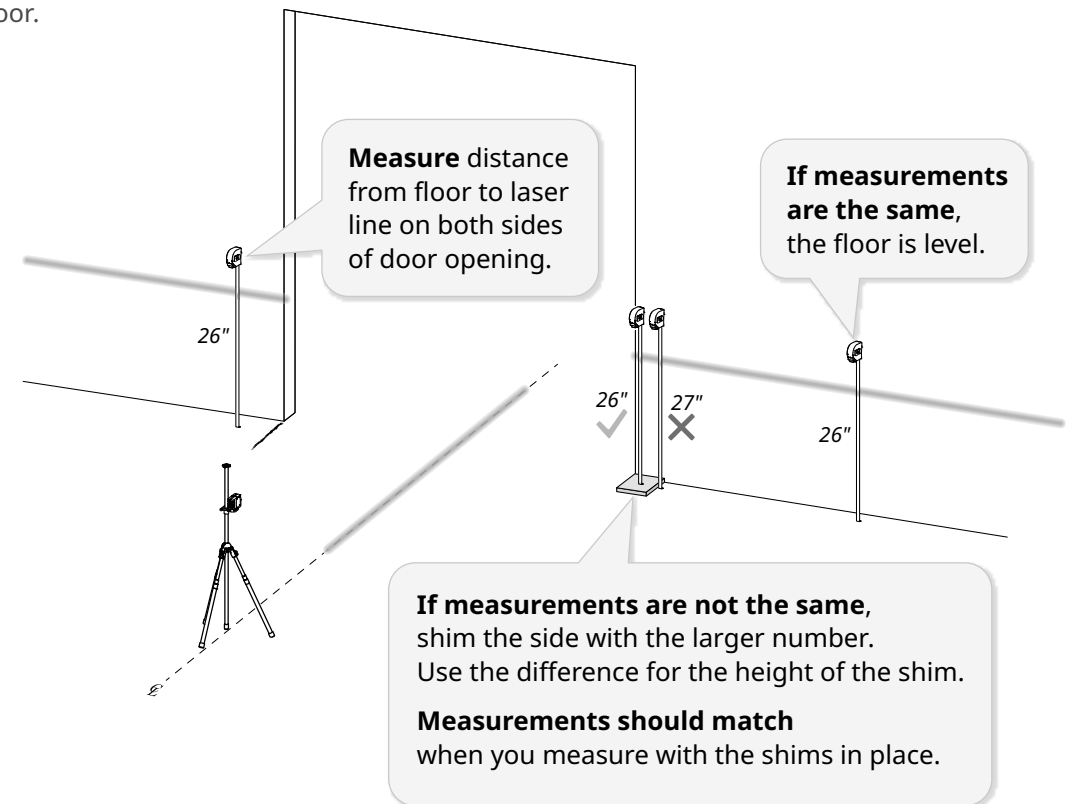
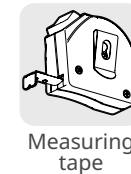

3 If the floor is level, install the drive side column first.
 If the floor is not level, install the side column that is not shimmed first.

4 Clamp the first side column into place.

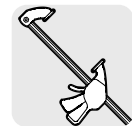

Bar clamp

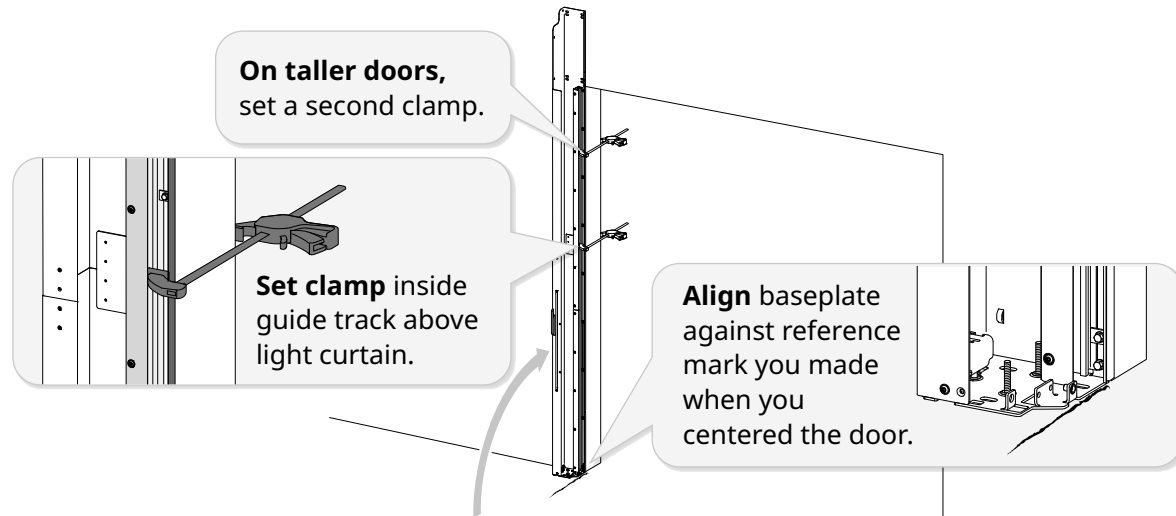

5 Plumb the side column.

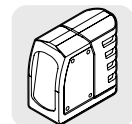

Laser level

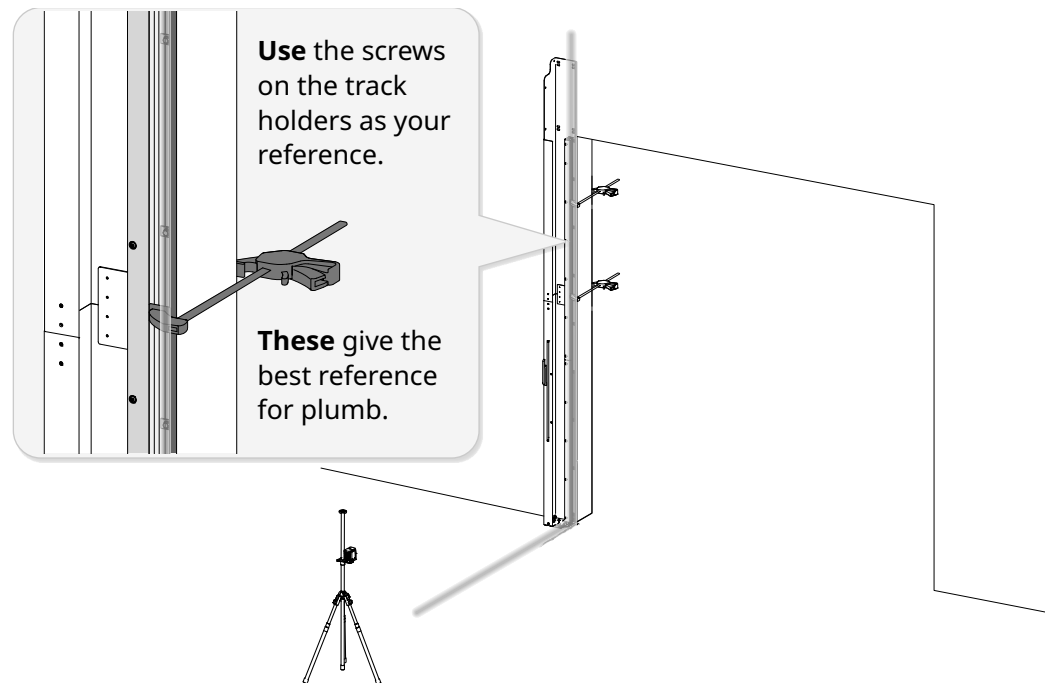

6 Anchor the first side column to the wall at the **top of the column** and **baseplate**.
 Set anchors tight. Remove clamp.

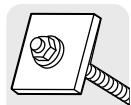

Anchoring hardware

IMPORTANT

Make sure you have read *Before you begin* on the previous page before you start.

7 Measure and mark the reference mark for the second side column.

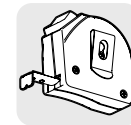

Measuring tape



Carpenter's square

Object list		Material number	
Original		724	
Material description	SPIRAL STT-L	Order number	20000597
Order type	ZP02	Order quantity	1 EA
MSP controller	500	Production scheduler	T7
BS ZMAT	Tier 7	RYTEC MTO Order	ZP02
Start	06/03/2019	Finish	06/05/2019
Status	REL MSPT PRT PRC SETC	Plant	2000
Plant	Rytec Corporation	Observation number	0002425475
Creation Date	05/31/2019		
Serial number	D0091893-010		
Configuration	DOOR MODEL NAME Spiral Full Vision "L"		
Door Width (Inches)	144.09*	144 1/16	①
Door Height (Inches)	128.346		
Production Width in mm	3,660		
Production Height in mm	3,260		
Door head size	Line Voltage 460V		
motor mount side	Right Hand Motor		
Motor Duty	Standard Duty Motor		
Horsepower	2.0		
Number of solid slats	0		
Number of vent slats	0		
Brake Release Location	Release lever on side column		
Hood style	No spiral hood type		
Number of Springs	4		
Spring Tension (in)	4.724		
SL Track Spacing (mm)	0		
SL Track Spacing (mm)	0		

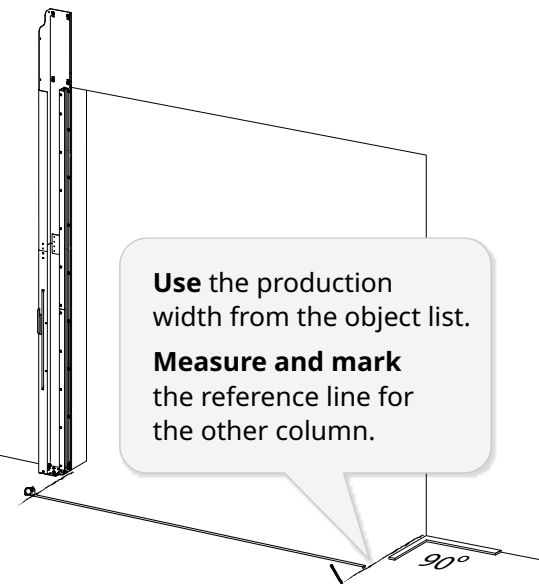

8 Clamp the non-drive side column into place.

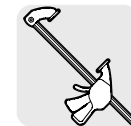

Bar clamp

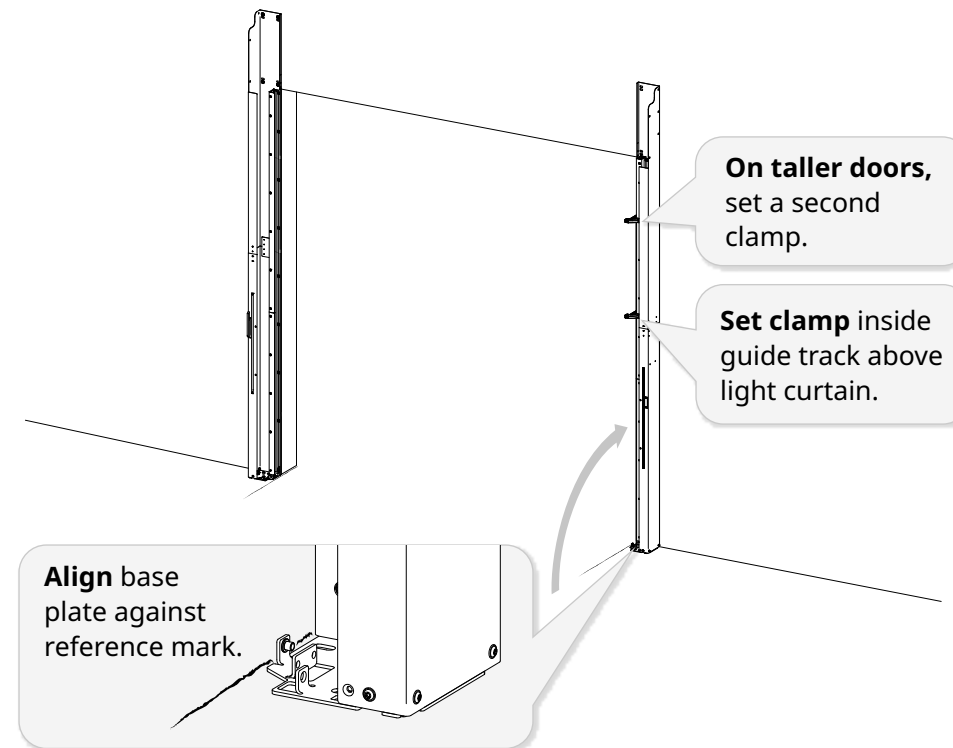

9 Anchor the second side column to the wall at the **top of the side column** and **baseplate**.
 DO NOT SET ANCHORS TIGHT until you have completed Step 3 on page 11.

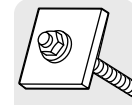

Anchoring hardware

IMPORTANT

Make sure you have read *Before you begin* on the previous page before you start.

10 Set a laser line parallel to the wall 1" (one inch) in front of columns. **Make sure** the line is parallel to the wall.



Measure the distance from the wall to the laser line at multiple locations.

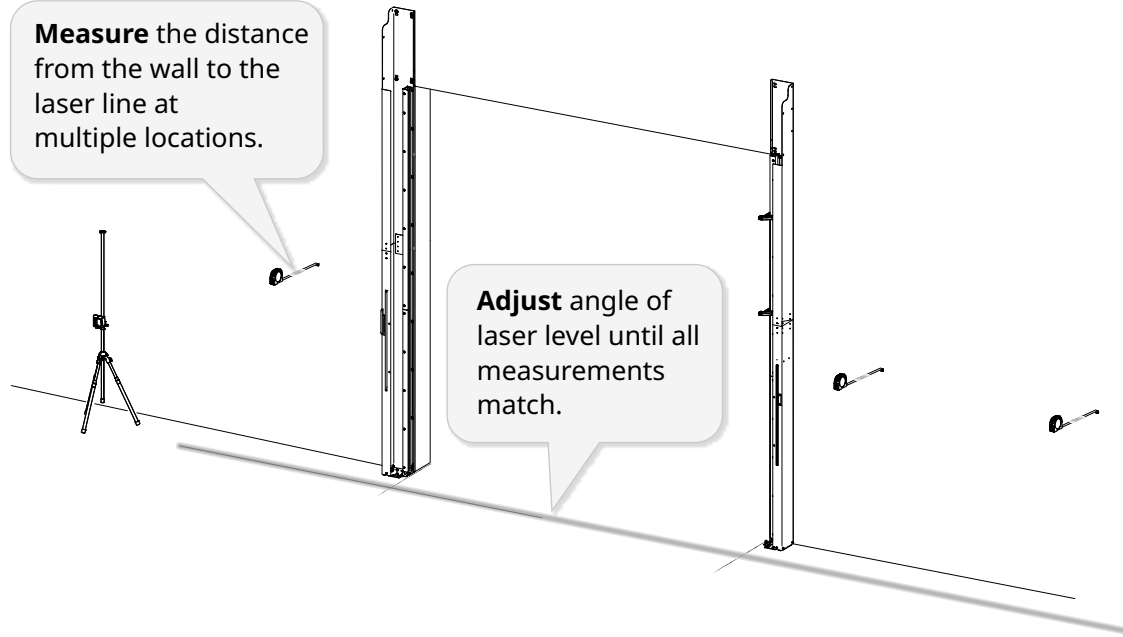

11 **Plumb** the side columns to each other.

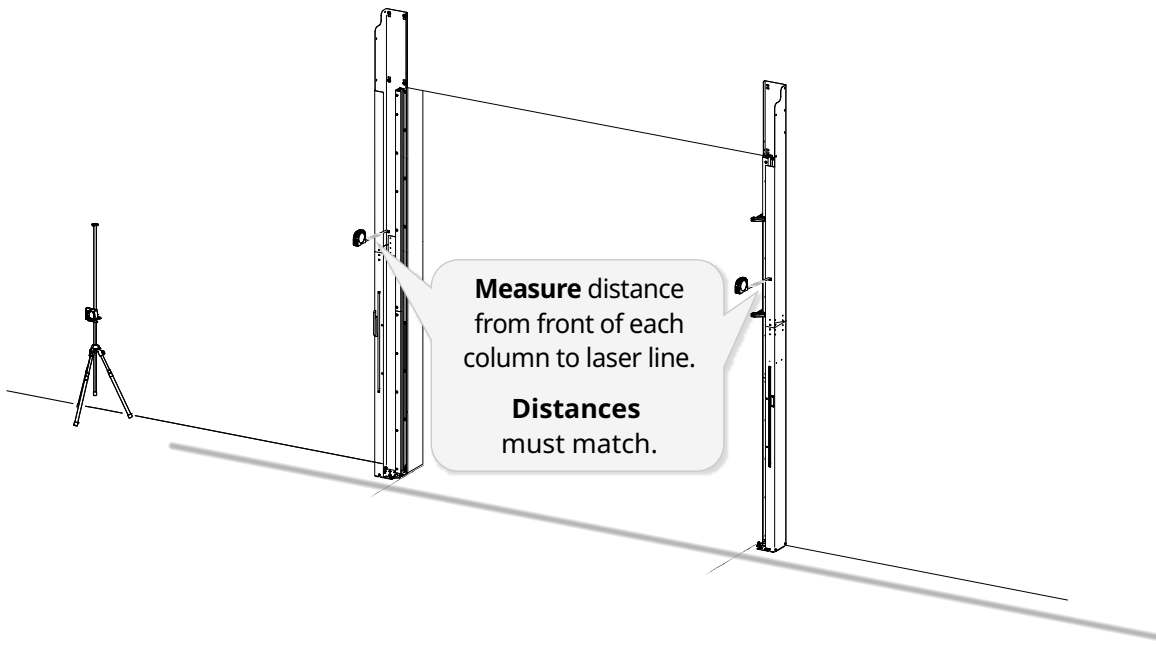

12 **If necessary, shim** the side columns so they are plumb to each other.

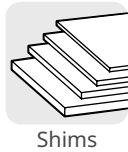

Step 2: Install the rear seal

1 Install bolts on both sides of the seal and **hand tighten**.

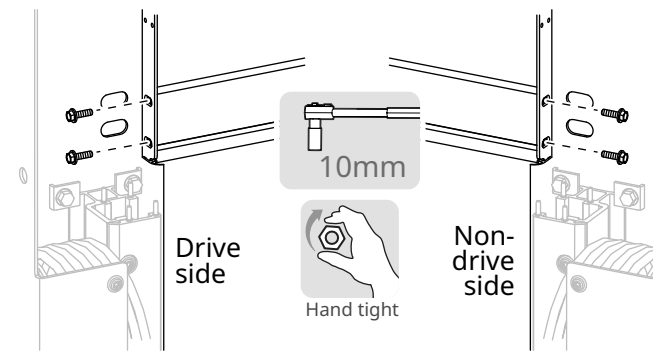

2 **Make sure** the back of the seal is flush with the back of the side column and that there is direct contact with the wall.

- If necessary, **shim the seal** where it meets both side columns and at the anchor point so that both conditions are met.

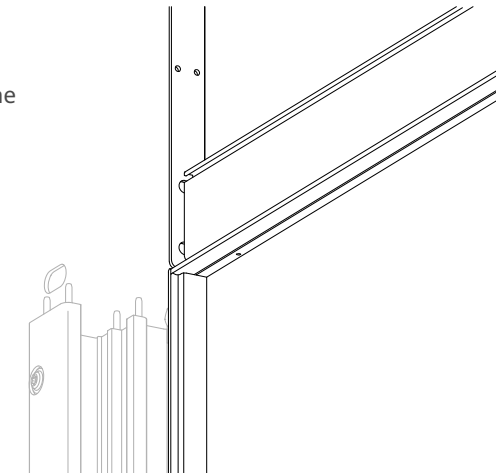
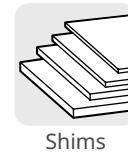

3 **Make sure** the rear seal is level.

Anchor rear seal to wall at all anchor points.

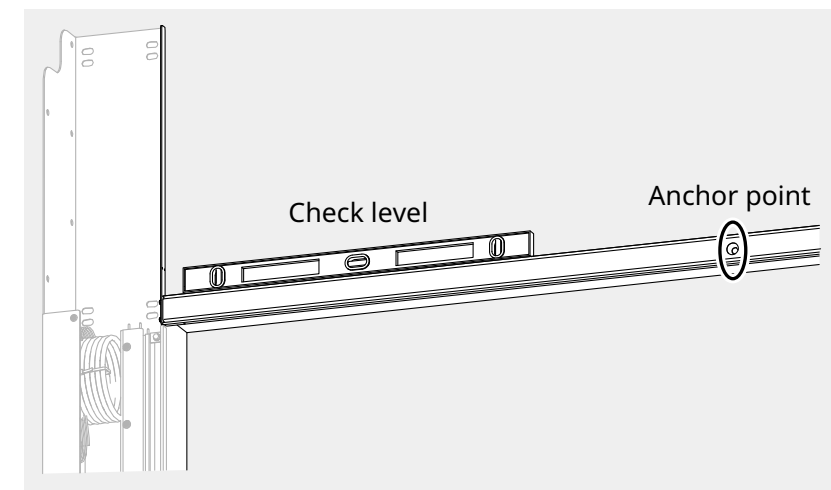
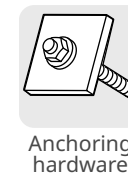

4 **Tighten** the bolts on both sides of the seal.

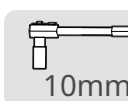

Step 3: Replumb and square the door and finish anchoring the side columns

1 Plumb both side columns from the front again. Realign if necessary.



Laser level

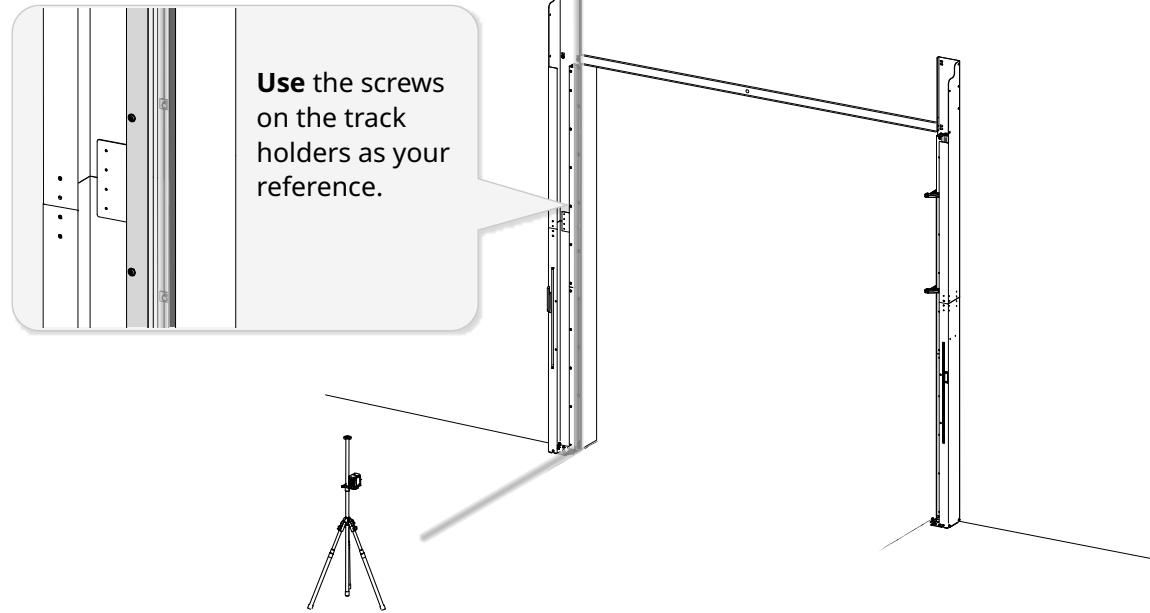

2 Square the door:

- Measure distance between side columns at top and bottom of columns ①. Make sure the distances are the same.
- Measure distance from bottom corner of drive side to top corner of non-drive side, then from bottom corner of non-drive side to top corner of drive side ②. Make sure the distances are the same.



Measuring tape

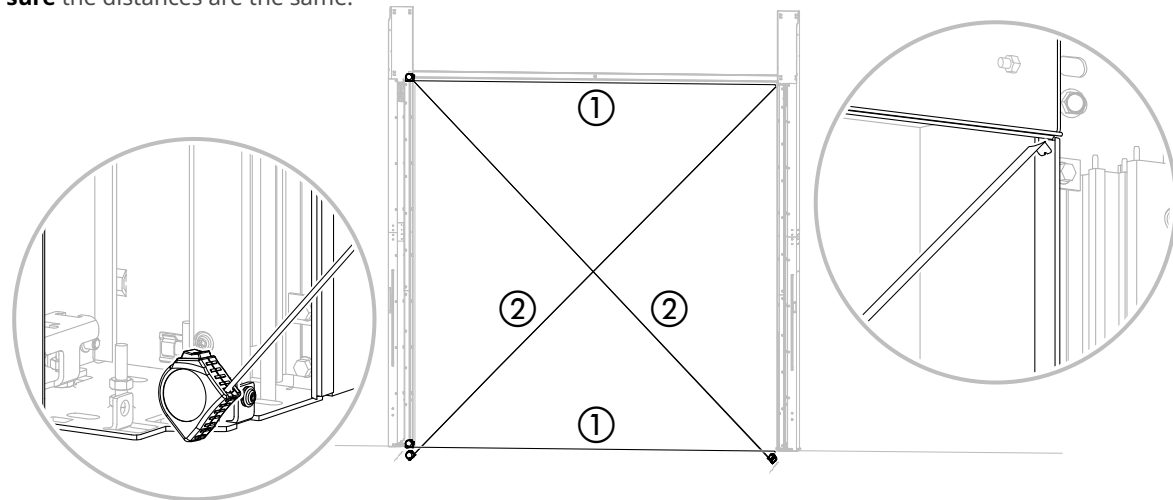

3 Tighten all anchors.



Anchoring hardware

How to install the head assembly

1 **INSIDER'S TIP** Line up the head assembly with the side columns before lifting.

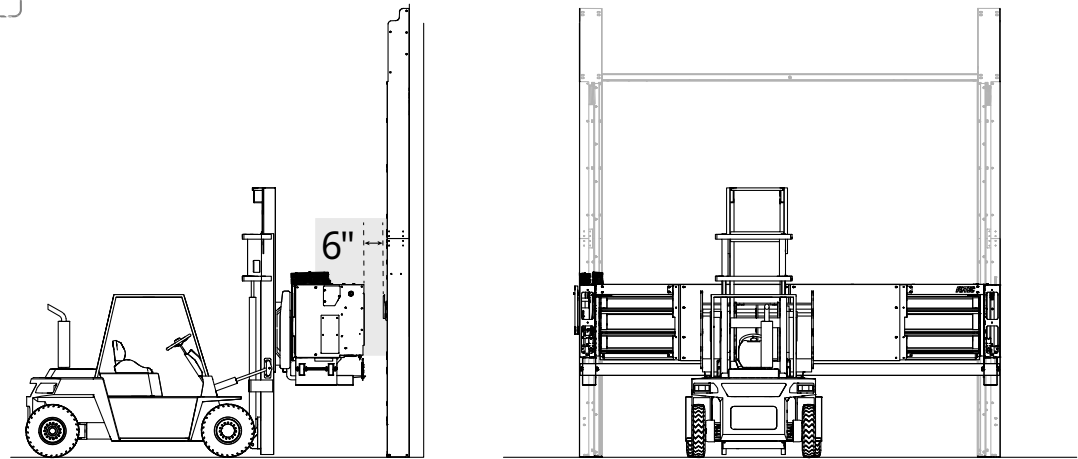

2

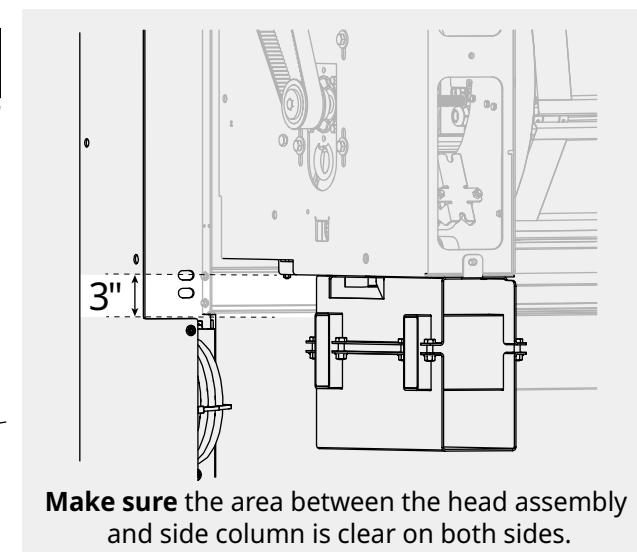
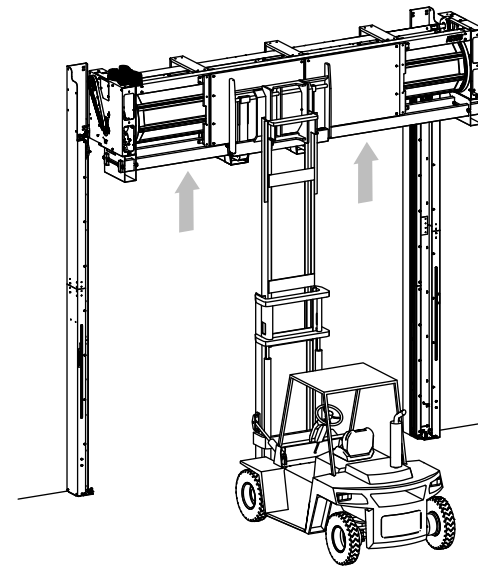

Make sure the area between the head assembly and side column is clear on both sides.

3

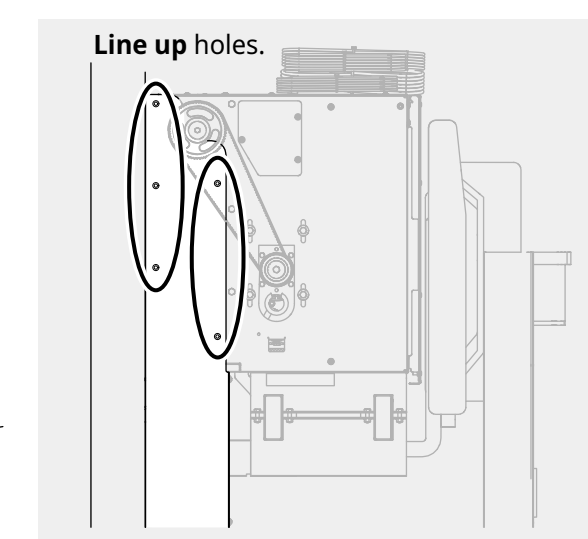
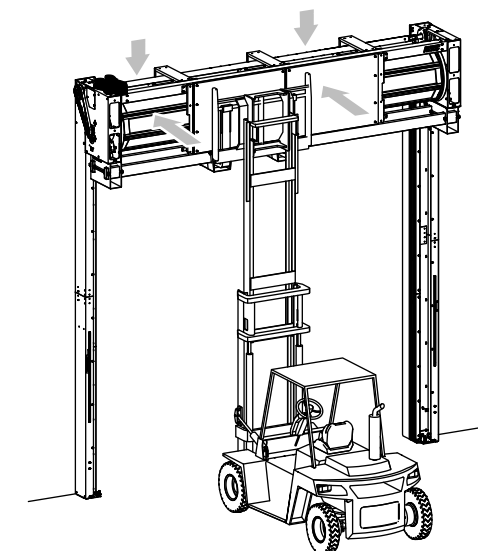

4 Secure the head assembly to the side columns.
Do this on both sides of the head assembly.

Start at the top and work around the screw holes.
Install screws and washers and hand tighten.
When all screws are seated, tighten screws.

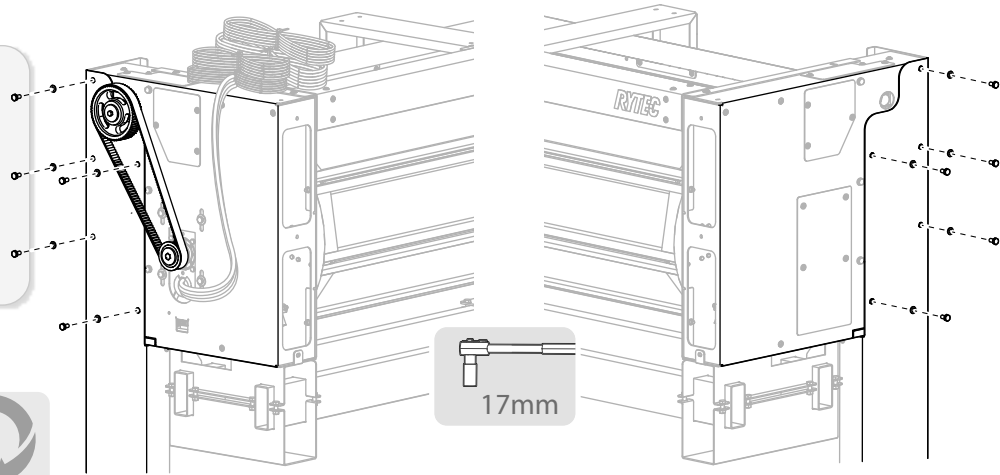
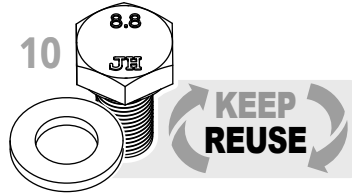

5 **-S and -S/R doors only:** loosen the screws on the wall mount brackets.
Place the brackets flush to the wall and anchor the brackets



If the door has a slanted top hood cover, do not install the outer anchors until the cover is installed.
Make sure the outer screws, washers and nut are not installed.

Use at least one anchor on each side of the bracket.

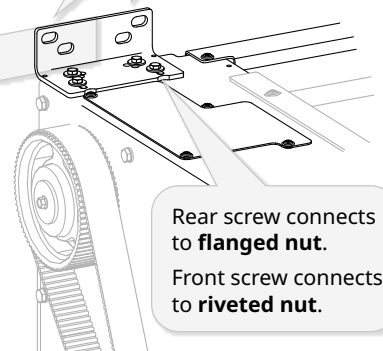

How to remove the cradle

1 Remove the two screws that attach the cradle to the head assembly.
Do this on both sides of the head assembly.
Remove the cradle by backing up, then lowering.

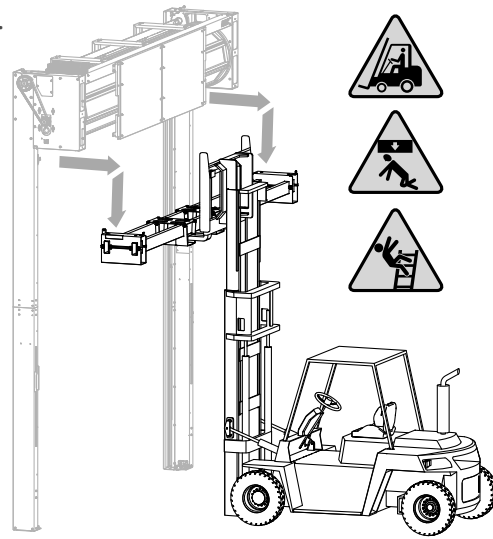
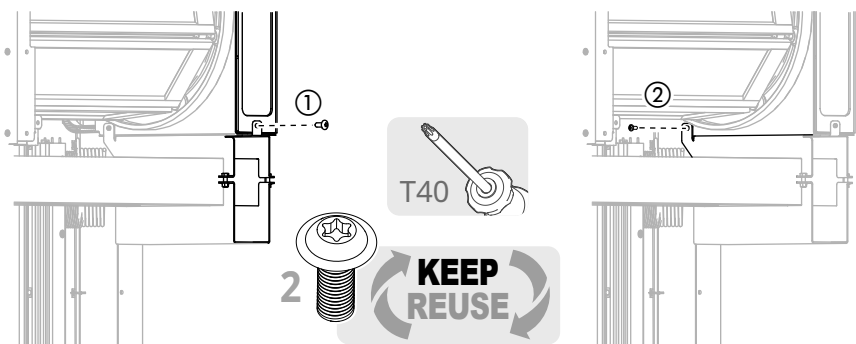

How to raise the vertical guide tracks into place

1 Make sure that all of the vertical guide track holders are loose enough to allow the track to move freely.
DO NOT remove any of the holders.

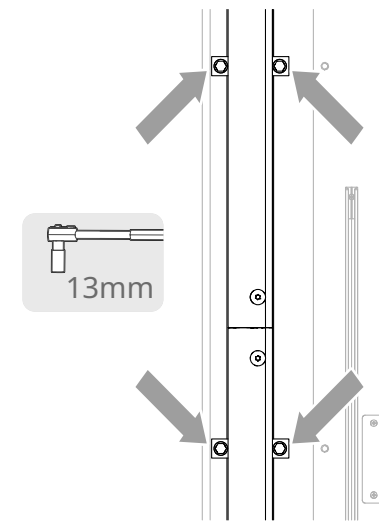

2 Make sure the pins at the top of the vertical guide track ① align with the holes in the head assembly track ②.



Use a pry bar to lift and hold the vertical guide track in place.

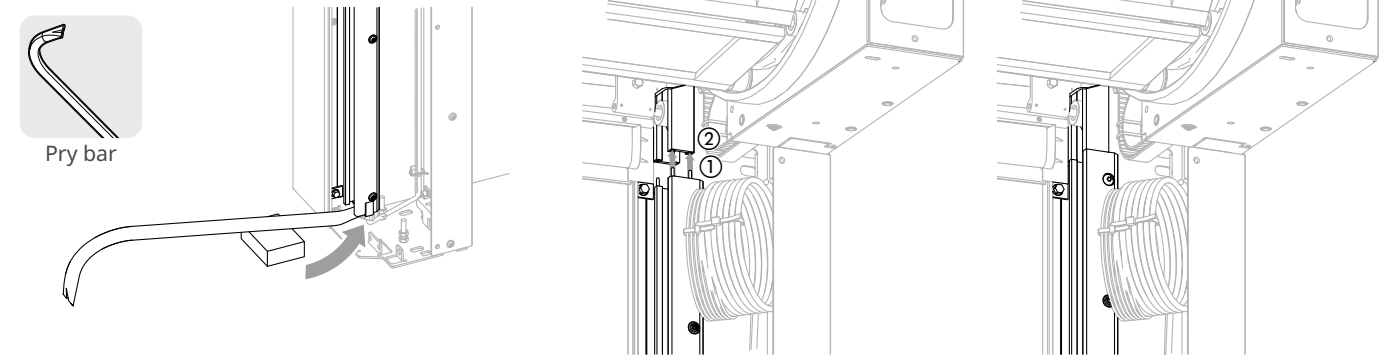

3 Tighten the bolts on the track holders.

- Start at the **middle of the track** and work toward the top and bottom.
- Make sure the holder is at a 90° angle to the track before tightening the bolt. You will need to hold it in place while tightening to keep it level.
- Make two full passes from top to bottom: tighten bolts to snug on the first pass, then fully tighten on the second pass.



CAUTION

Make sure your fingers are clear of the bolt when tightening. Power tools are not recommended.

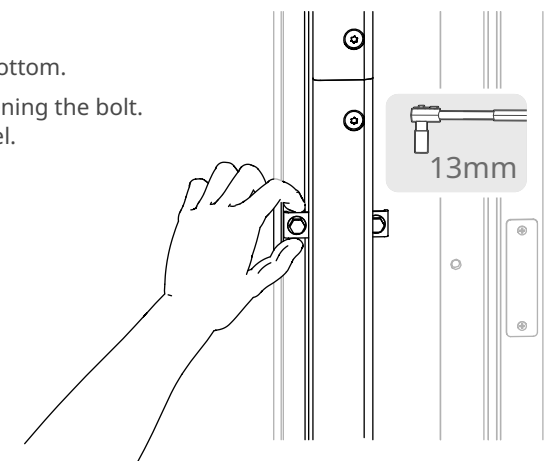

How to run the drive side cables for Pathwatch and light curtain

1 Cut the ties on the cables in the side columns.



Cutting pliers



INSIDER'S TIP

Tape ends of cables together and run them together.

Make sure both cables run cleanly, with no slack, kinks or loops. Check whole length of cable as you go.

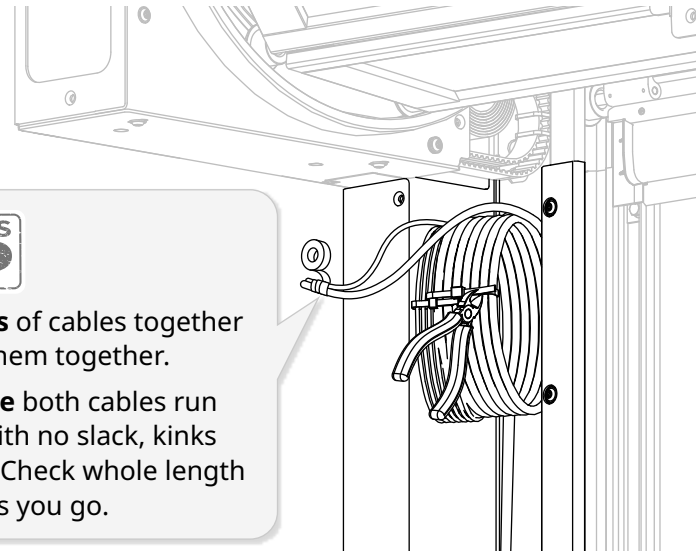

2 Locate the wire chase at the back of the console.

You may have to move the spring strap to the side to see the chase.

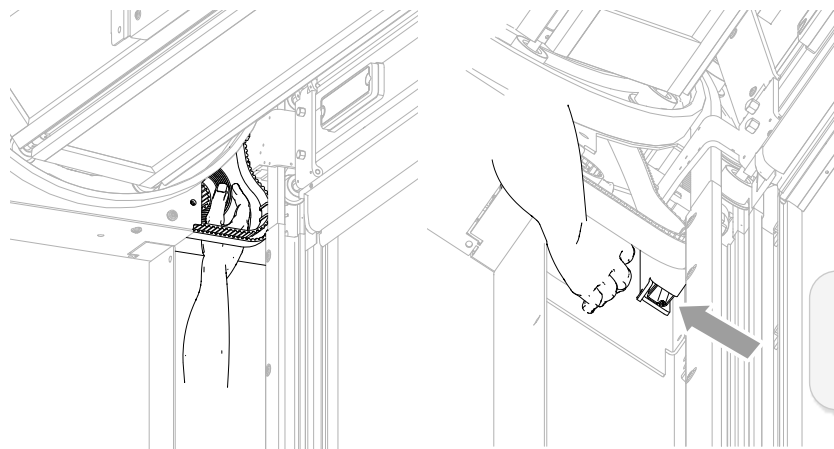

Wire chase is a rectangular white plastic tube.

3 Pull cables through chase.

Make sure the full length of both cables is run through the chase and that both cables are tight against the back of the console.

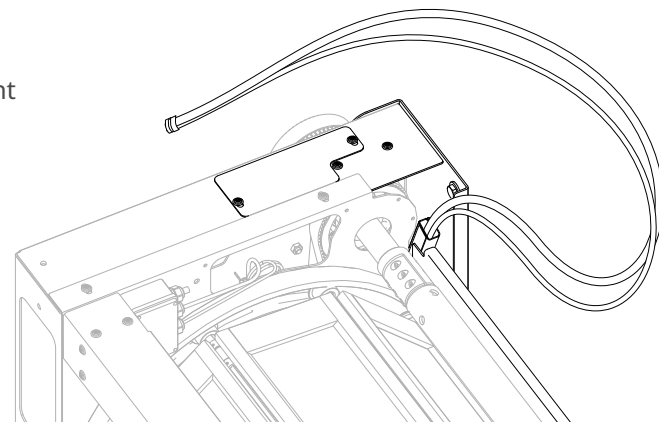

How to run the non-drive side cables for Pathwatch and light curtain

1 Cut the cable ties.

Locate the chase.

Pull the cables completely through the wire chase.



Cutting pliers

2 Run cables across rear spreader.

Tuck cables under lip of spreader.



Cable ties

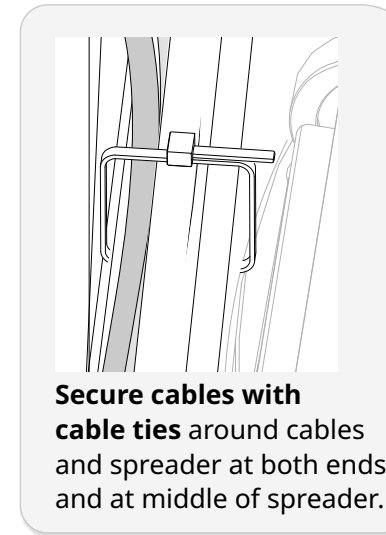
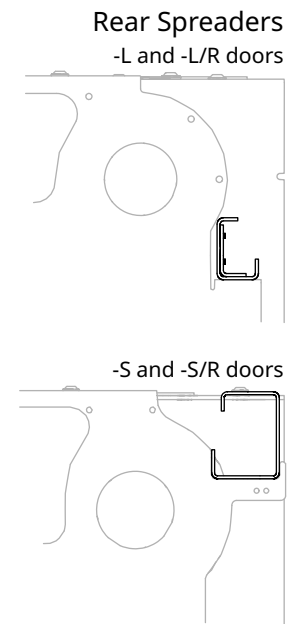

Secure cables with cable ties around cables and spreader at both ends and at middle of spreader.

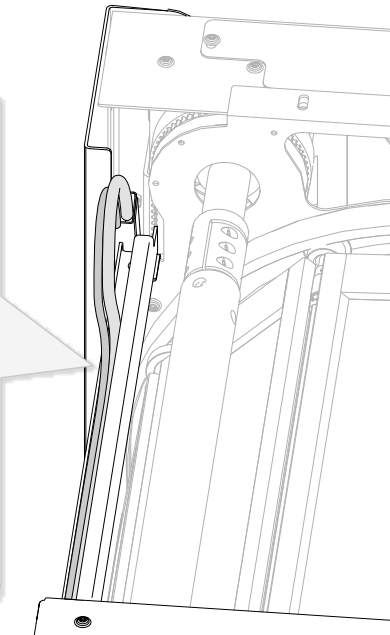

3 Splice the Pathwatch cables together near the drive side wire chase.

Run the longer drive side splice to the controller.



Wire stripper



Wire nuts and electrical tape



Cable ties

INSIDER'S TIP

Add cable tie around cables and spreader beyond splice point.

Tape all three cables together for strain relief.

IMPORTANT Use UL-rated wire nuts.

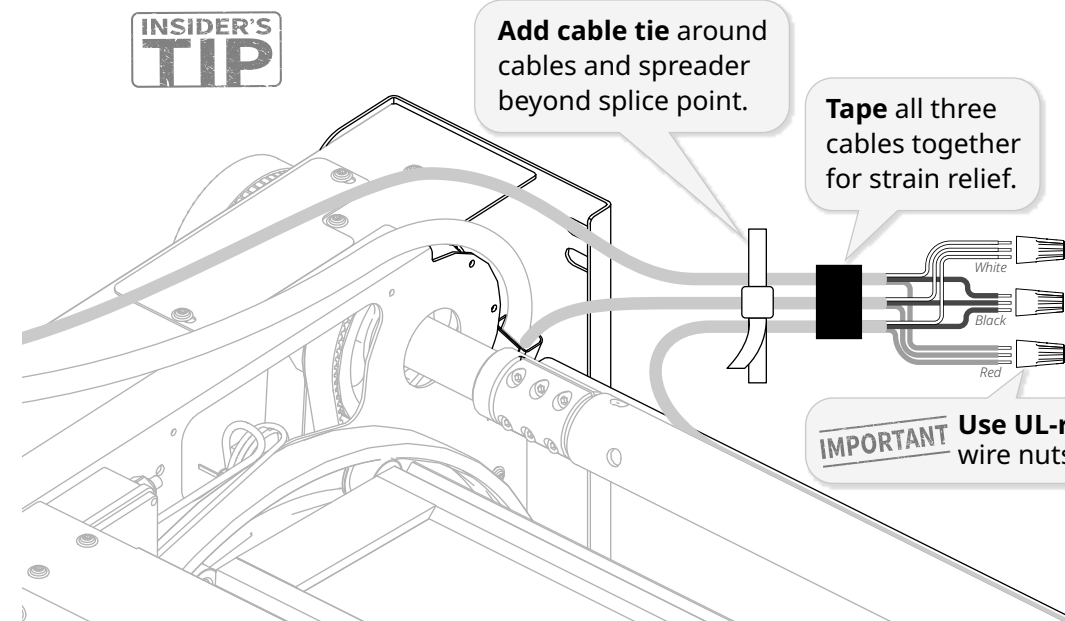

- 4** Run all cables together along the outside of the console.
Tie cables down at all tie points.



Cable ties

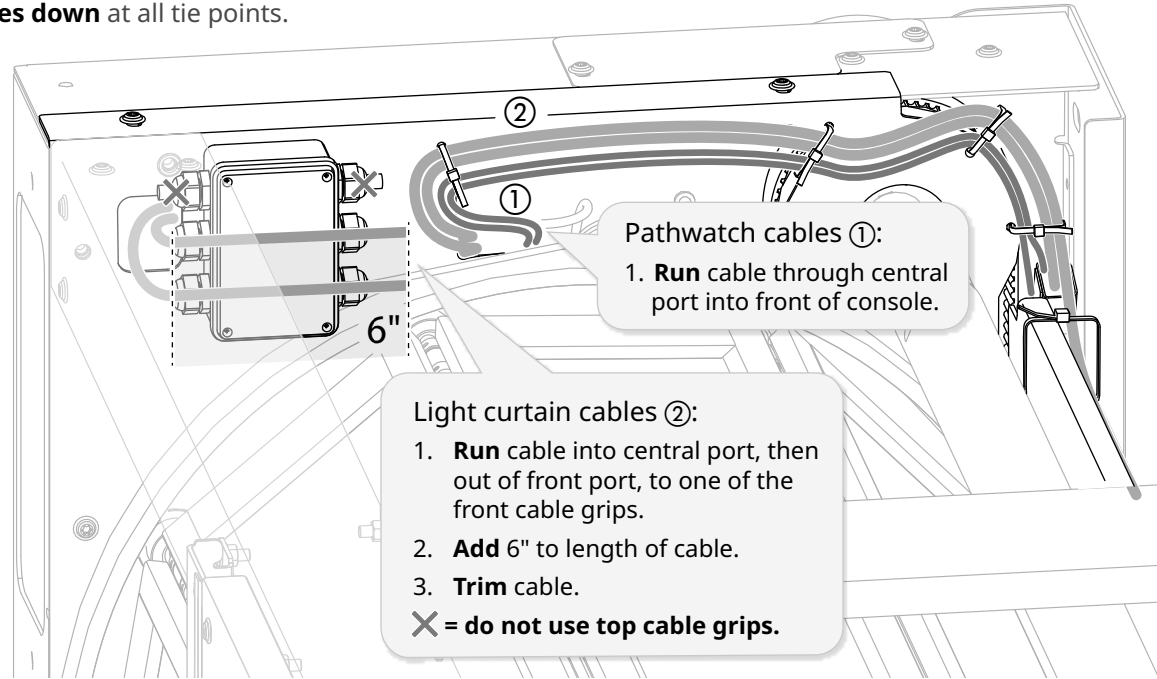

- 5** Run the Pathwatch cable(s) through front of console and out of the cable port.
Place the cable(s) with the other head assembly cables.

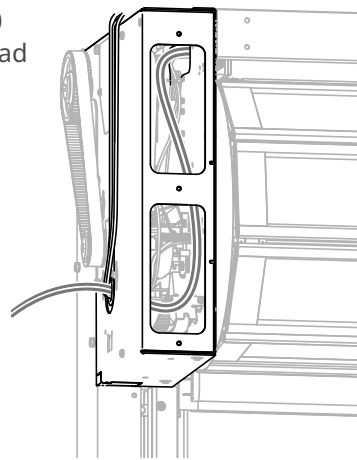

- 6** Loosen the four capture screws on the X-10 junction box cover ① and pull off the cover.

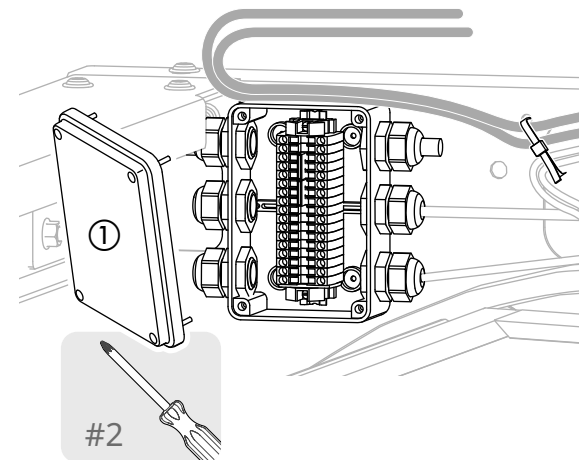

- 7** Run the light curtain cables through the cord grips.
1: Remove the cord grip covers ②.
2: Thread the cables through the covers.
3: Remove the plug ③ from the middle cord grip and discard.
4: Thread the cables through the cord grips.
5: Pull cables tight and tighten down the cord grip covers.

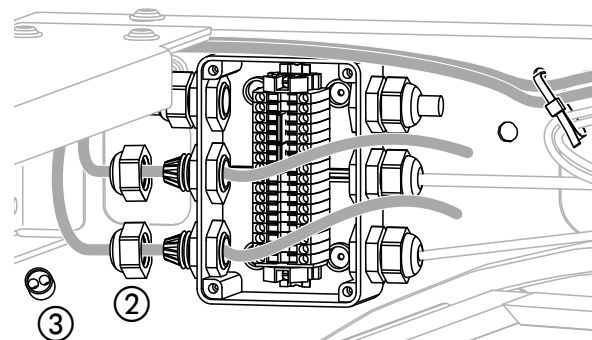

- 8** Find the schematics for the door in the red document envelope.

IMPORTANT

Check the crate and small parts boxes for accessories such as activators or safety devices and any schematics included with them.

If the schematics indicate the door has non-standard wiring, follow the schematics instead of this manual.

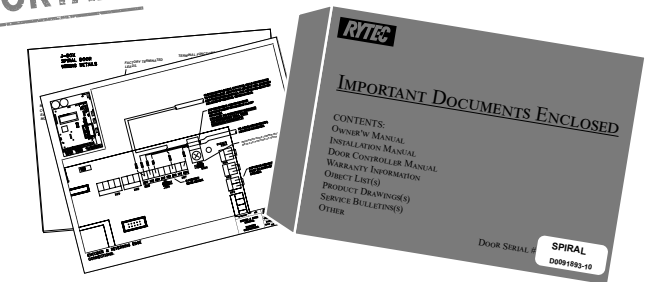

- 9** Wire the light curtains to the terminals in the X-10 junction box. Replace the cover.

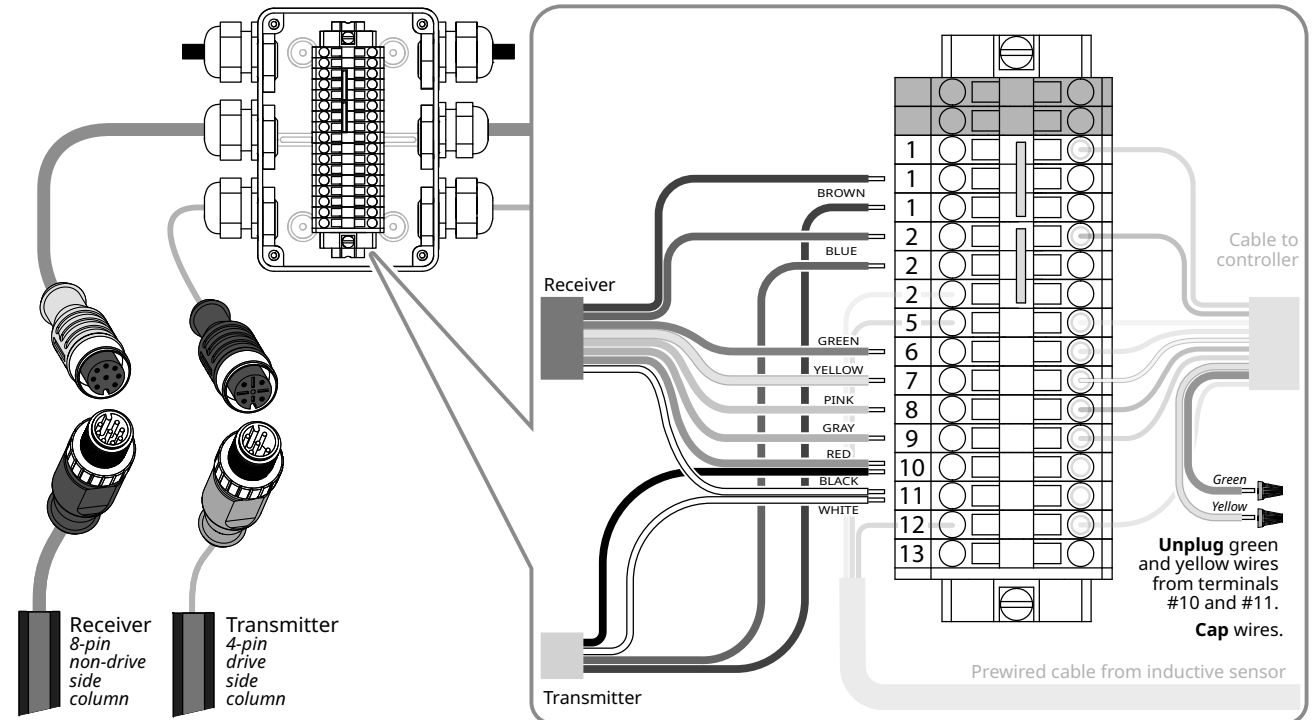

Wire stripper



Precision screwdriver

How to open a terminal connection

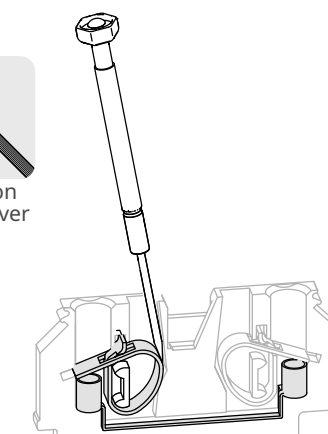

1. Slide the screwdriver into the square opening until the flat blade wedges against the spring inside.

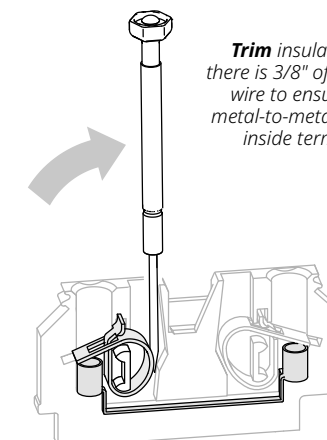

2. Twist the screwdriver while pushing down to pry the spring open.

Trim insulation so there is 3/8" of exposed wire to ensure full metal-to-metal contact inside terminal.

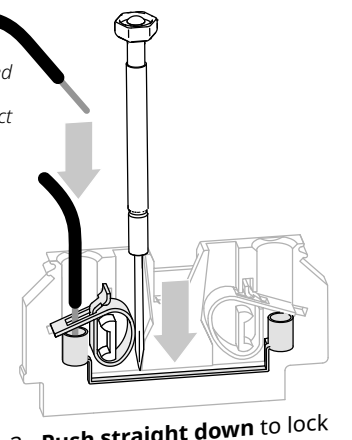

3. Push straight down to lock the spring open.
4. Push in the wire until it is fully seated, then remove the screwdriver.

How to install the springs

- 1 **Make sure** the total number of springs in the crate matches the number listed in the object list ①. The object list also shows how to divide the springs between the side columns ②.
- Make sure** the preinstalled spring straps on both sides of the head assembly match the table below ③ for the total number of springs in the door.

RYTEC		Object list		Material number	
Original		SPIRAL STT-L		724	
Material description	SPIRAL STT-L	Order number	20000597	Order quantity	1 EA
MSP number	500	Production schedule	T7	Older type	ZP02
	B5 ZMAT		Tier 7	RYTEC MTO Order	06/03/2019
Start	06/03/2019	Finish	06/05/2019		
Plant	2000	Reservation number	0002425475	Creation Date	05/31/2019
Material number	DD091893-010				
Configuration					
DOOR MODEL NAME Spiral Full Vision "L"					
Door Width (Inches) 144.094					
Door Height (Inches) 128.346					
Production Width in mm 3,660					
Production Height in mm 3,260					
Door head size 8					
Line Voltage 460V					
motor mount side Right Hand Motor					
Motor Duty Standard Duty Motor					
Horsepower 2.0					
Number of solid slats 0					
Number of vent slats 0					
Brake Release Location Release lever outside column					
Hood style No spiral hood type					
Number of Springs 4					
Spring tension (lbs) 4,724					
LH Inner Spring Pack Qty 0					
LH Outer Spring Pack Qty 2					
RH Outer Spring Pack Qty 2					
RH Inner Spring Pack Qty 0					
Spring tension in mm 120					
Number of pre-wraps 2,250					



Locate the parts and hardware the spring assemblies in both si

Each assembly includes:

- 1-3 springs
- guide tubes
- a guide bracket
- a strap bracket

When there are more than three springs in a side column, two assemblies are installed side by side and bolted together.

The table to the right shows how to divide the parts and hardware found in the small parts box(es) and how to put together the assemblies.

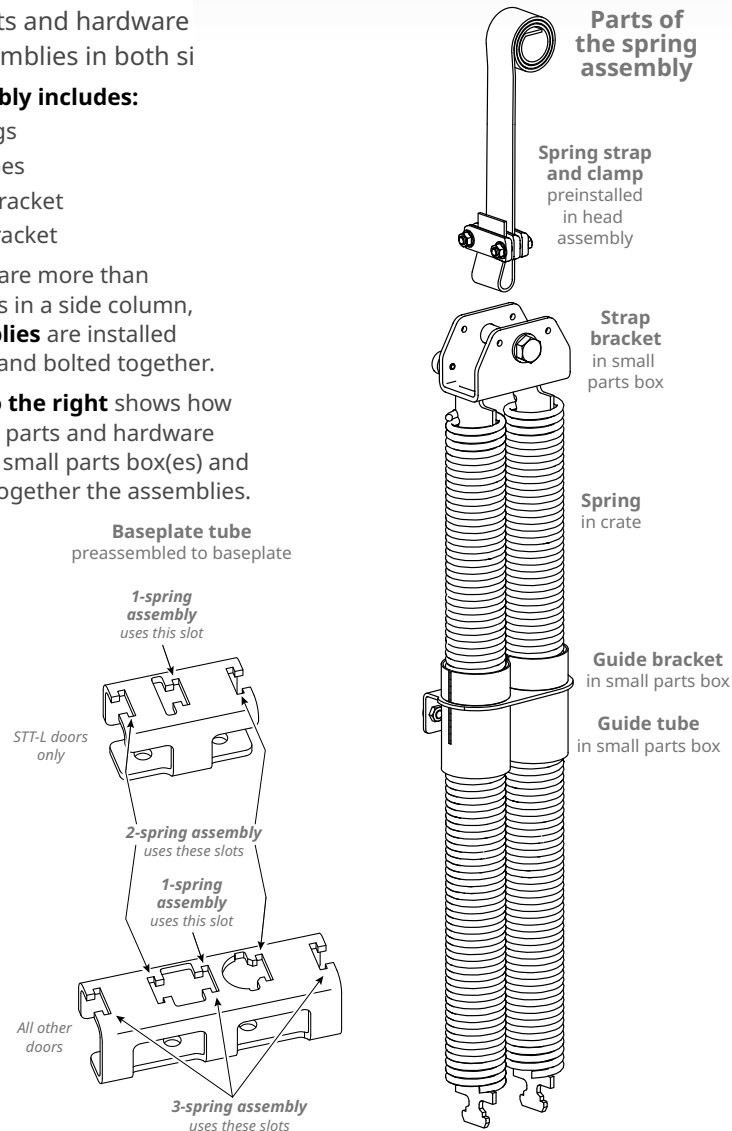

Total number of springs			Drive side			Non-drive side				
	Springs	Spring straps	In small parts box: guide tube(s), strap bracket, guide bracket(s)			Springs	Spring straps	In small parts box: guide tube(s), strap bracket, guide bracket(s)		
1						1	1	1		
2		③				2	1	2		
3	1	1	1			2	1	2		
4	2	1	2			2	1	2		
5	2	1	2			3	1	3		
6	3	1	3			3	1	3		
7	3	1	3			4	2	4		
8	4	2	4			4	2	4		
9	4	2	4			5	2	5		
10	5	2	5			5	2	5		
11	5	2	5			6	2	6		
12	6	2	6			6	2	6		

Hardware (in small parts box)

Hardware to attach outer guide brackets to side column wall

2 01900812

IMPORTANT

Match 01900812 screws to this illustration to make sure length is correct. Other screws used in the Spiral have the same head style, but are too long for the guide bracket nut and will damage the door.

Hardware to attach inner guide bracket to outer guide bracket

01901506

2 01260110

NOTE: a four-spring, two-assembly configuration is shown for these steps.



It is recommended that you **do not use power tools** for these steps. Overtorquing screws can damage parts.

2 **Install** the guide tubes into the guide bracket. **Squeeze** the top of the tube, then slide the tube into a guide hole until it clicks into place.

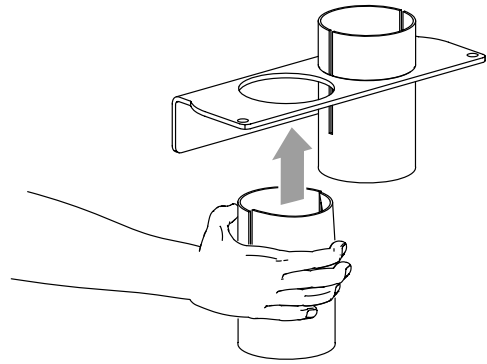

3 **Install** the bracket into the side column.

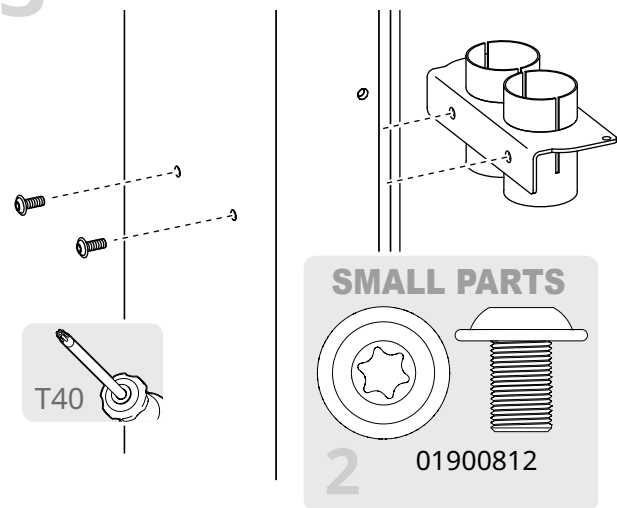

SMALL PARTS

2 01900812

4 **Slide** the top of the springs into the bracket.

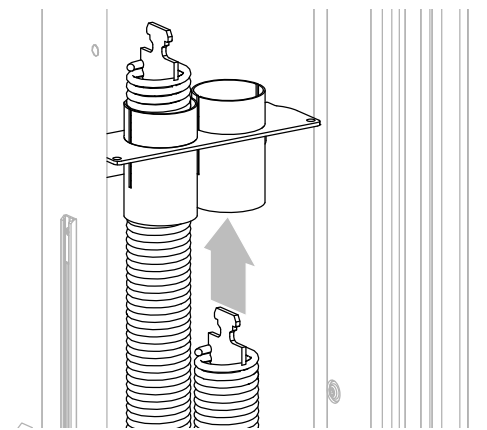

5 **Slide** the bottom spring tabs into the wide slot ①, through the narrow ②, then **pull up** into the retaining slot ③. The spring should remain upright.

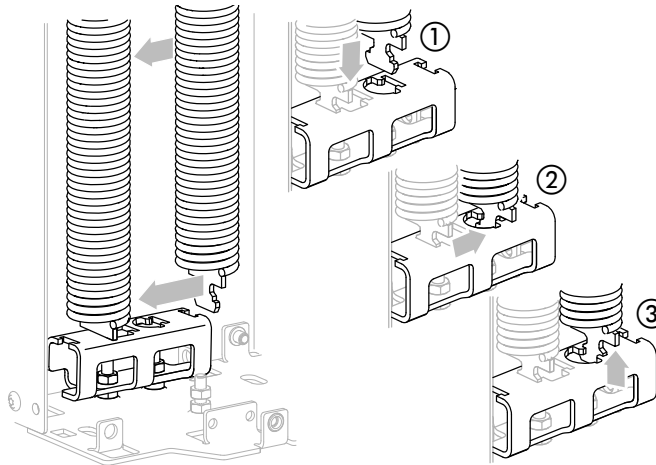

6 **Make sure** the number of wraps for the spring strap matches the object list ①. **Look through** the front of the console or temporarily **remove** the top access cover.

Production Width in mm 3,660
 Production Height in mm 3,260
 Door head size B
 Line Voltage 460V
 motor mount side Right Hand Motor
 Motor Duty Standard Duty Motor
 Horsepower 2.0
 Number of solid slats 0
 Number of vent slats 0
 Brake Release Location Release lever on side
 Hood style No spiral hood type
 Number of Springs 4
 Spring Tension (in) 4.724
 LH Inner Spring Pack Qty 0
 LH Outer Spring Pack Qty 2
 RH Outer Spring Pack Qty 2
 RH Inner Spring Pack Qty 0
 Spring Tension in mm 120
Number of pre-wraps 2.250 ①

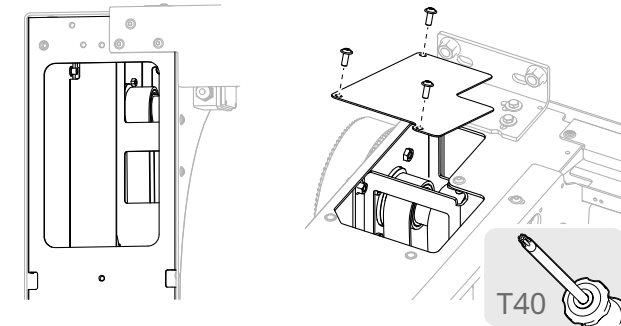

IMPORTANT **DO NOT unspool the strap or change the number of wraps** unless you are in contact with Rytec technical support at **800-628-1909**. **The wraps are required** for the door to operate correctly.

7 **Cut the cable tie** on the outer spring strap and let it drop.

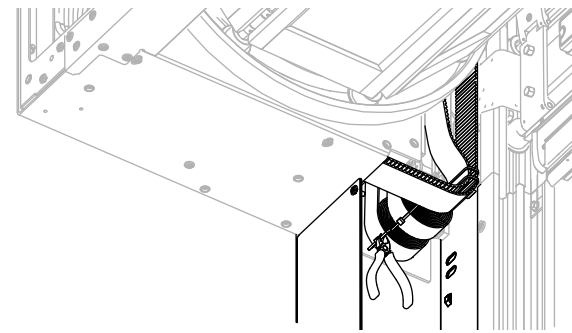

8 **Loosen** the clamp on the spring strap.

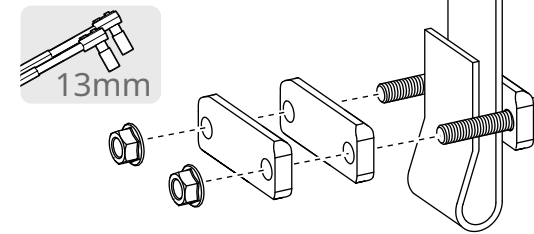

9 **Position** the spring bracket so that the bumpers and locking tab face the side wall.

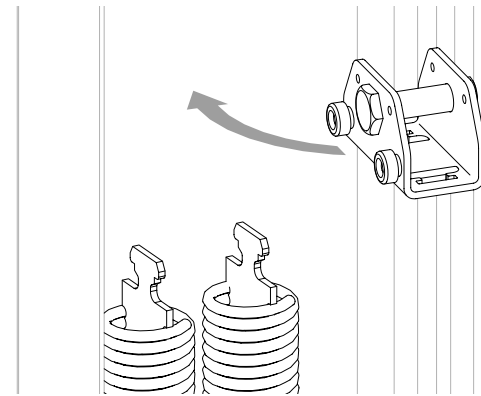

10 **Loop the spring strap** around the bolt in the spring bracket.

Thread the strap between two plates of the clamp. **Make sure** the clamp stays two inches (2") above the bracket.

Hand tighten the clamp nuts.

IMPORTANT

DO NOT trim the strap.

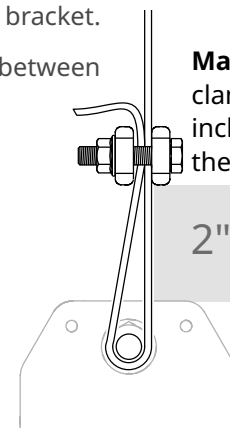

11 **Set the spring tension.** This is the distance the springs must be stretched to provide the correct tension for the door.

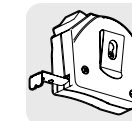

Measuring tape

Locate the spring tension ① on the object list. **Round** to the nearest 1/16 inch.

Measure the distance between the bottom of the spring bracket and the top of the spring tab (shaded area).

.063	1/16	.313	5/16	.563	9/16	.813	13/16
.125	1/8	.375	3/8	.625	5/8	.875	7/8
.188	3/16	.438	7/16	.688	11/16	.938	15/16
.250	1/4	.500	1/2	.750	3/4		

Configuration

DOOR MODEL NAME	Spiral Full Vision "L"
Door Width (Inches)	144.094
Door Height (Inches)	128.346
Production Width in mm	3,660
Production Height in mm	3,260
Door head size	B
Line Voltage	460V
motor mount side	Right Hand Motor
Motor Duty	Standard Duty Motor
Horsepower	2.0
Number of solid slats	0
Number of vent slats	0
Brake Release Location	Release lever on side column
Hood style	No spiral hood type
Number of Springs	4
Spring Tension (in)	4.724 4-3/4 ①
LH Inner Spring Pack Qty	0
LH Outer Spring Pack Qty	2
RH Outer Spring Pack Qty	2
RH Inner Spring Pack Qty	0
Spring Tension in mm	120
Number of pre-wraps	2.250

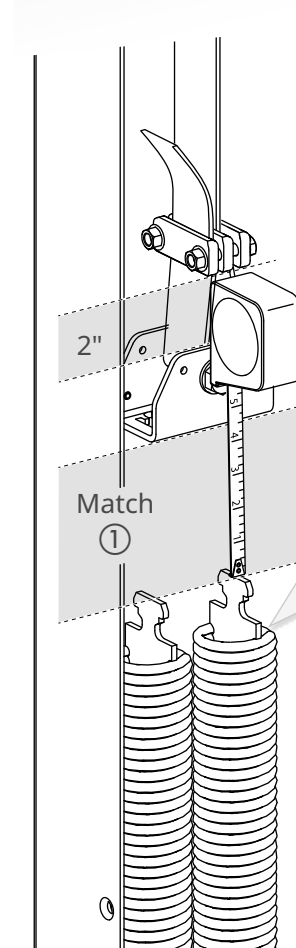

IMPORTANT
Make sure the spring is standing straight up and does not sag while you measure.

12 Adjust the strap until the measured distance matches the object list and the distance from the clamp to the bracket is two inches (2").

13 Remove the nuts and **retrieve** the third clamp plate.

Loop the spring strap down between the second and third clamp plate.

Tighten the nuts to secure the strap.

If necessary, **trim** excess strap length.

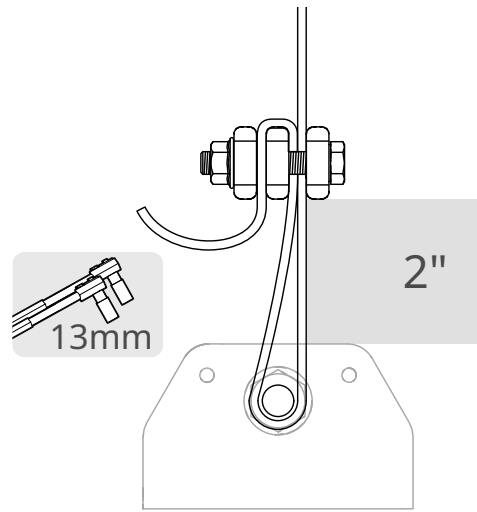

14 Release each spring from the baseplate tube.

Lift each spring and **slide** the spring tab into the slot in the spring bracket.

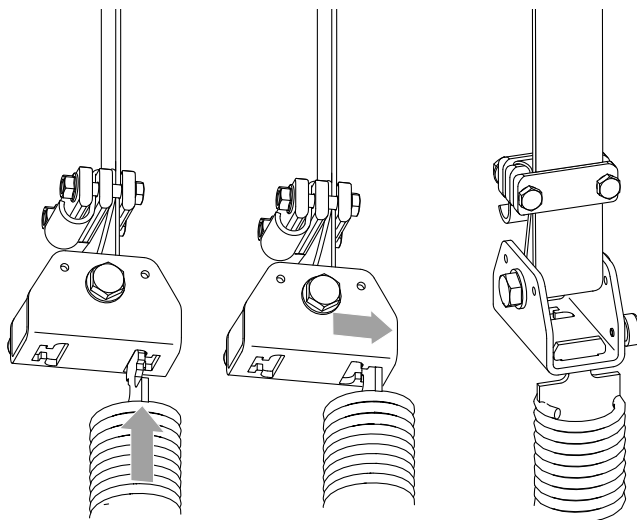

15 Stretch the springs downward. **Slide** the bottom spring tabs into the wide slot ①, through the narrow ②, then **pull up to lock** it into the retaining slot ③.

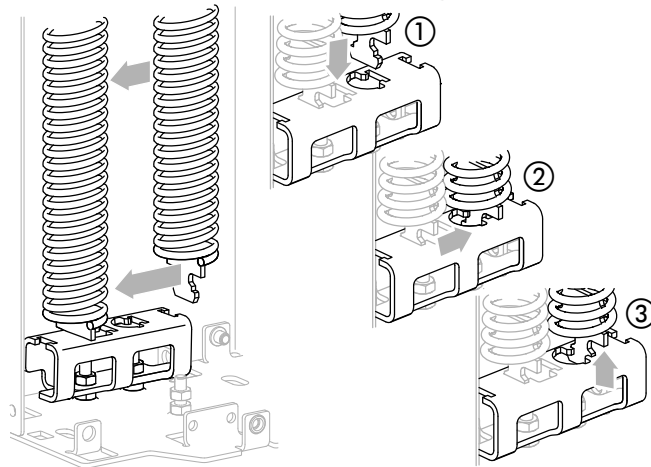

How to install a second assembly in the side column

1 Install the guide tubes into the second bracket. **Install** the second bracket above the first bracket.

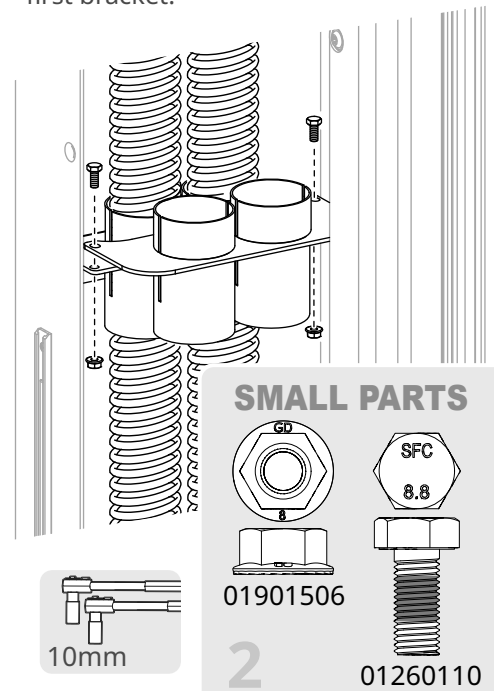

2 Follow steps 4-15 for installing the springs. **Make sure** the spring bracket bumpers face out, toward the first spring assembly.

How to install the secondary drive belt

1 IMPORTANT Make sure the secondary drive belt is kept taut throughout these steps.

- The belt is preinstalled around the pulley ①.
- The **door panel end bracket** ② is connected at the precise height to keep the door panel level.
- The belt is kept taut to the pulley and end bracket during crating by **two cable ties** ③.
- **If the belt becomes loose** before it is secured to the baseplate, it can skip a tooth in the pulley. **This will cause the door panel to run crooked and damage the door.**

Keep downward pressure on the secondary drive belt until the baseplate pulley assembly ④ is installed and the belt has been properly tensioned.

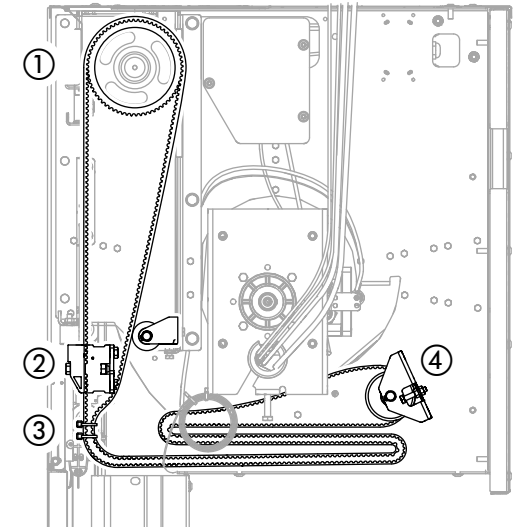

2 Pull the secondary drive belt and baseplate pulley assembly out of the console.

Lower them down the side column.

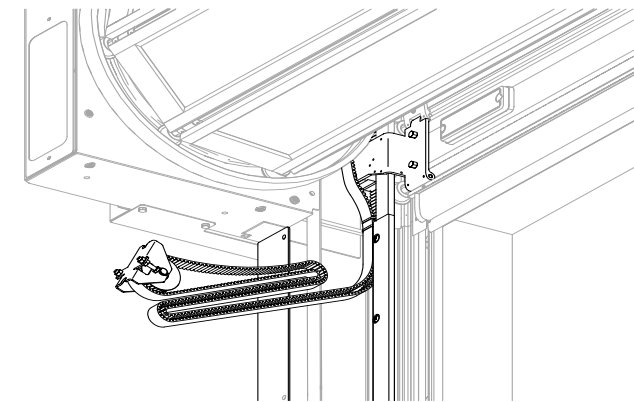

3 Grab the belt below the cable ties and pull gently downward to keep the belt tight.

Cut the two cable ties to release the belt.

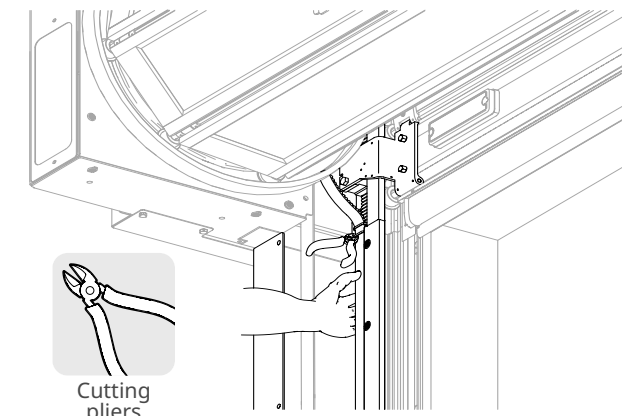

4 Remove the top nut on the front baseplate mounting post.

Keep the nut.

Loosen the top nut on the rear mounting post.

IMPORTANT DO NOT loosen the bottom nuts.

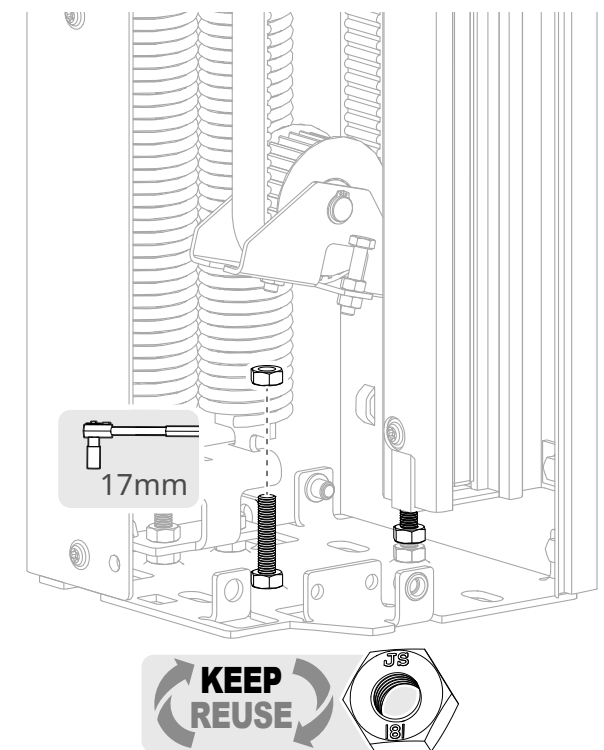

- 5 Set the height** of the top nut on the rear baseplate mounting post ①.
- 1: Slide** the rear flange of the baseplate pulley assembly ② **under the top nut** until it touches the post.
 - 2: Press down** on the front of the pulley assembly as hard as you can ③.
 - The top nut is at the correct height when **three (3) threads of the front mounting post clear the front flange**.
 - 3: Adjust** the height of the nut as needed to reach the correct height.

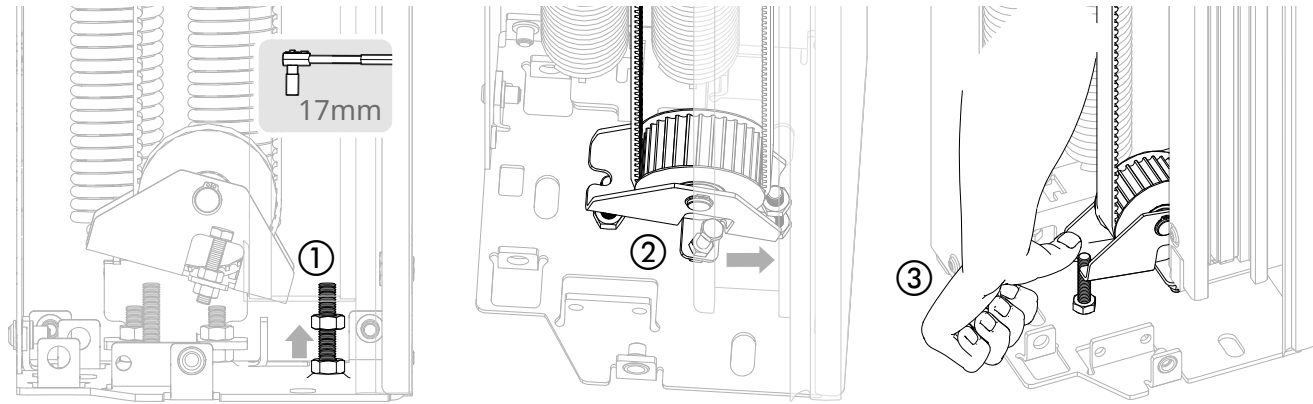

- 6 Set the tension** of the belt.
- 1: Replace** the top nut on the front mounting post. **Tighten** the nut to increase the tension on the belt.
 - 2: Grab** the belt as close as possible to the midpoint with one hand. **Press** the front and rear legs of the belt together between your fingers and thumb.
 - The tension is correct when it requires **considerable effort to bring the legs together**.
 - 3: Adjust** the height of the top nut as needed to reach the correct tension.

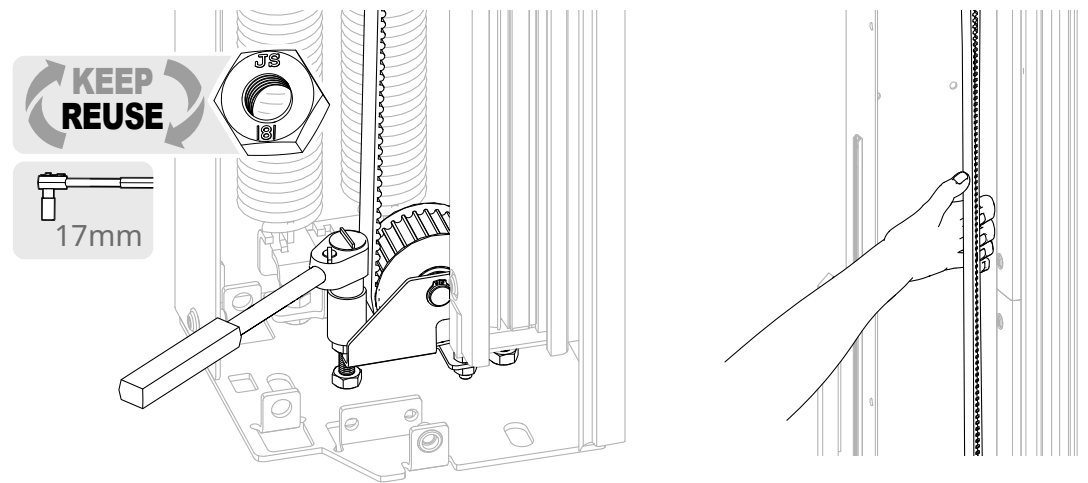

How to install the locking collars at the top and bottom of the springs

Install the locking collars onto the tabs at the top and bottom of each spring after the secondary drive belts have been tensioned.

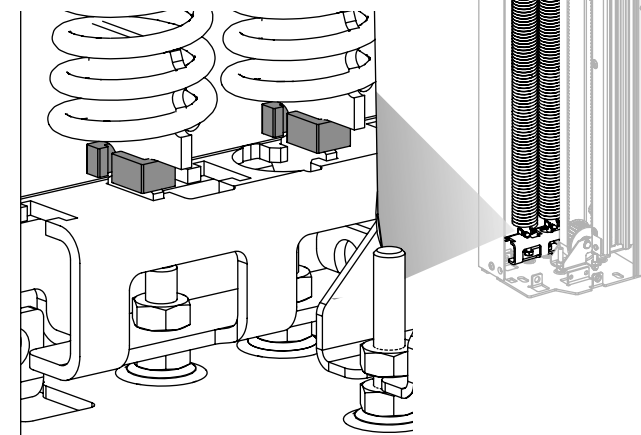
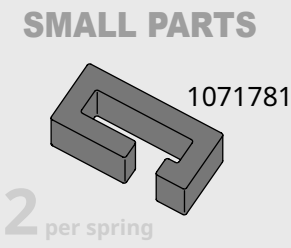
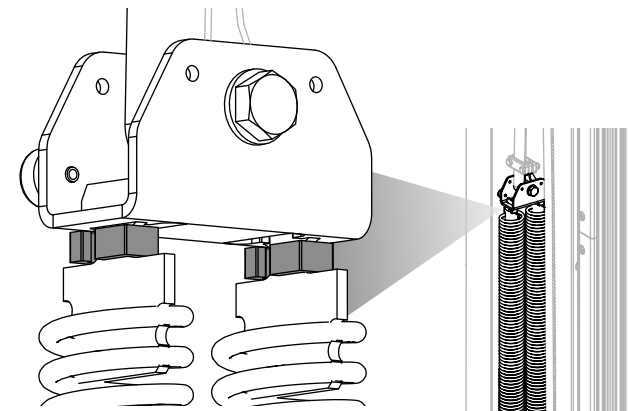

1 Install collar into the top tab:

- 1 Slide** the opening in the collar onto the tab.
- 2 Twist, then push** the collar across the tab (the collar is flexible and will bend open enough to fit).
- 3 Push** the short end around until it clicks into place.

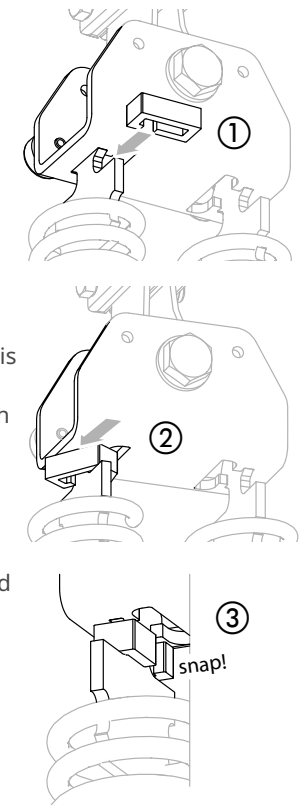

2 Follow the same steps for the tab at the baseplate pulley assembly.

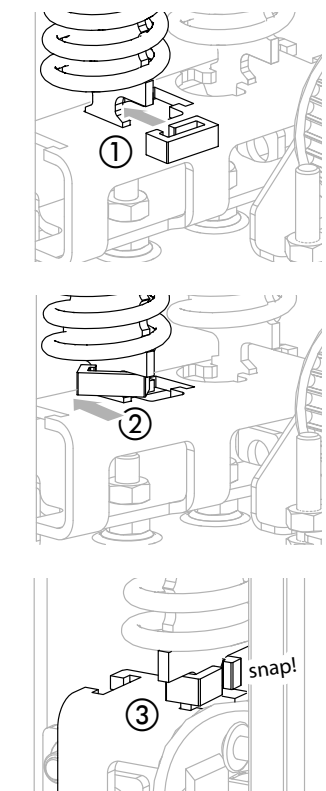

How to install the corner brackets, wireless antenna and (optional) bottom hood spreader

1 **Locate** the corner brackets, wireless antenna arm and hardware in the small parts box.

Install a corner bracket on each side column.

- **The drive side bracket** holds the wireless antenna arm and has an extra screw hole to secure the side panel cover.
- **The non-drive side bracket** has an extra screw hole to secure the side panel cover.

NOTE: depending on the configuration of the door, the drive side may be on the left (LH) or right (RH) side of the door. These steps show a left hand (LH) door.

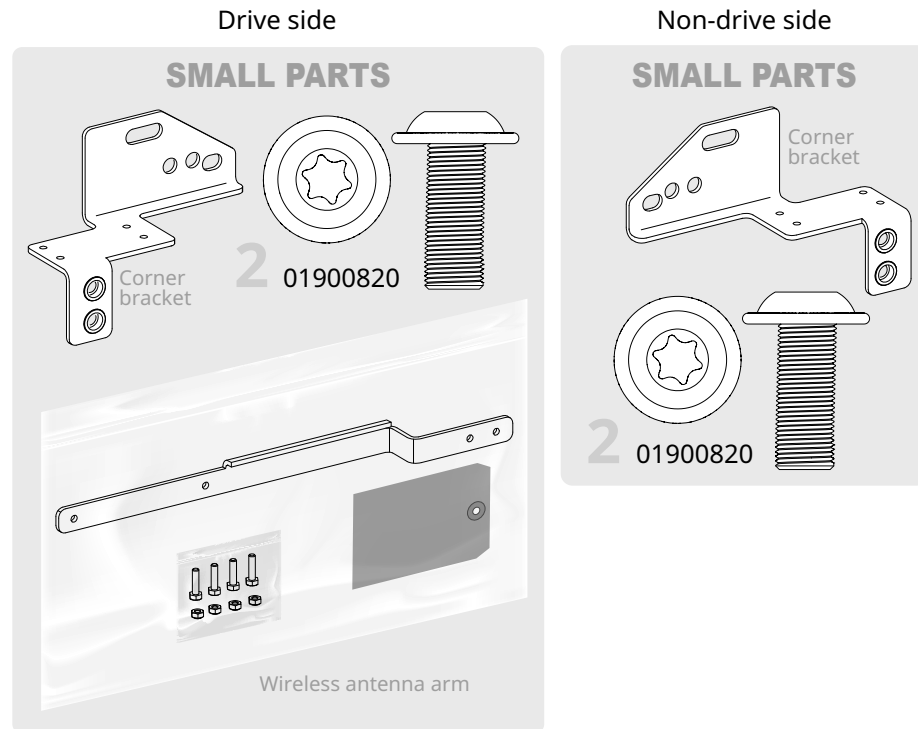

2 **If the door has a bottom hood cover:**

- **Locate** the two spreader brackets and hardware for the bottom hood spreader in the small parts box
- **Locate** the bottom hood spreader.

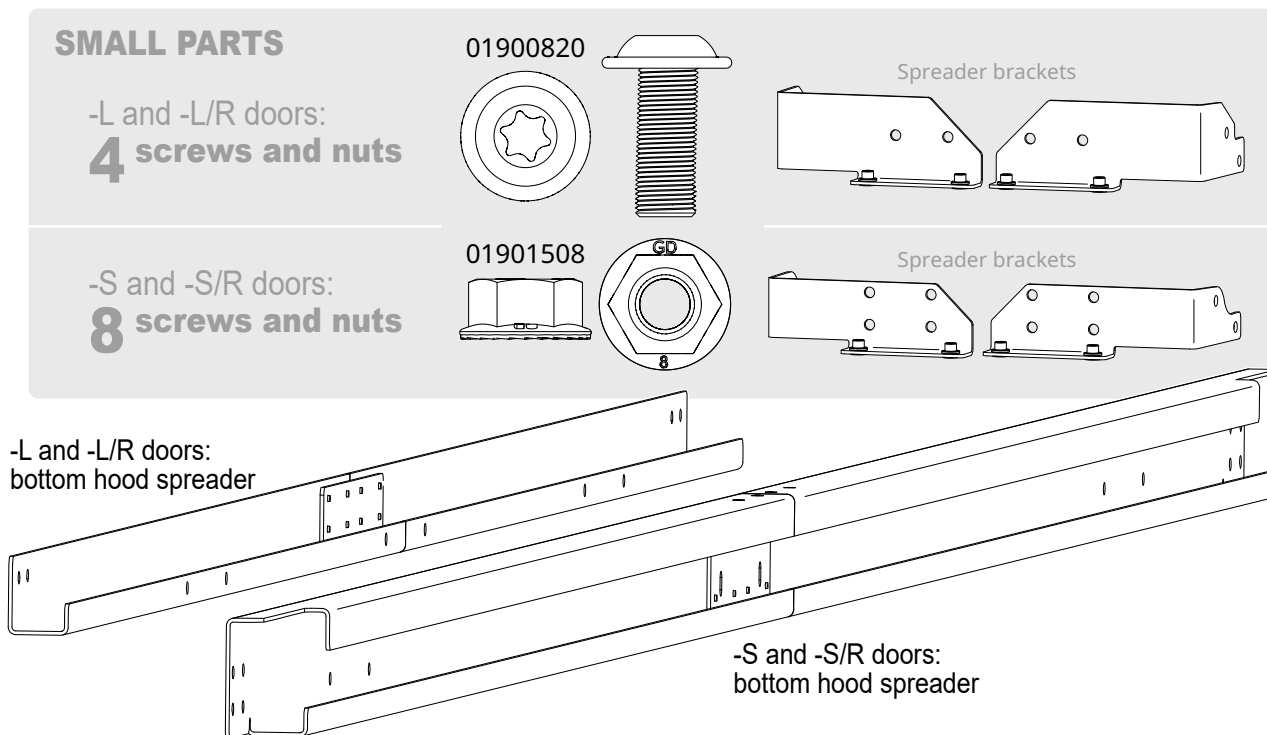

3 **If the door has a bottom hood cover, attach** the spreader brackets to the bottom hood spreader.

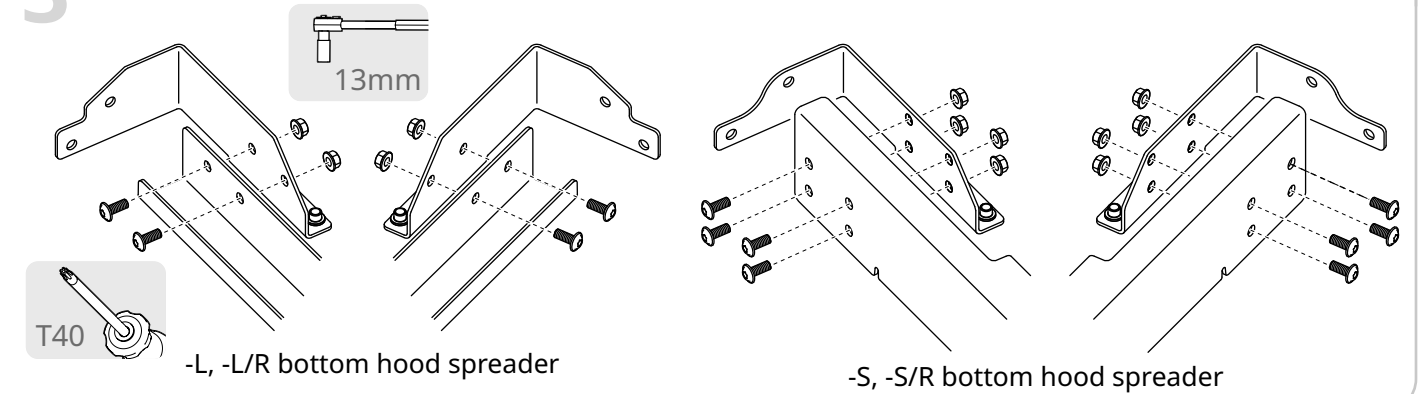

4 **Install** the corner brackets.

If the door has a bottom hood cover, install the bottom hood spreader inside the corner bracket, using the same screws.

Do this on both sides of the head assembly.

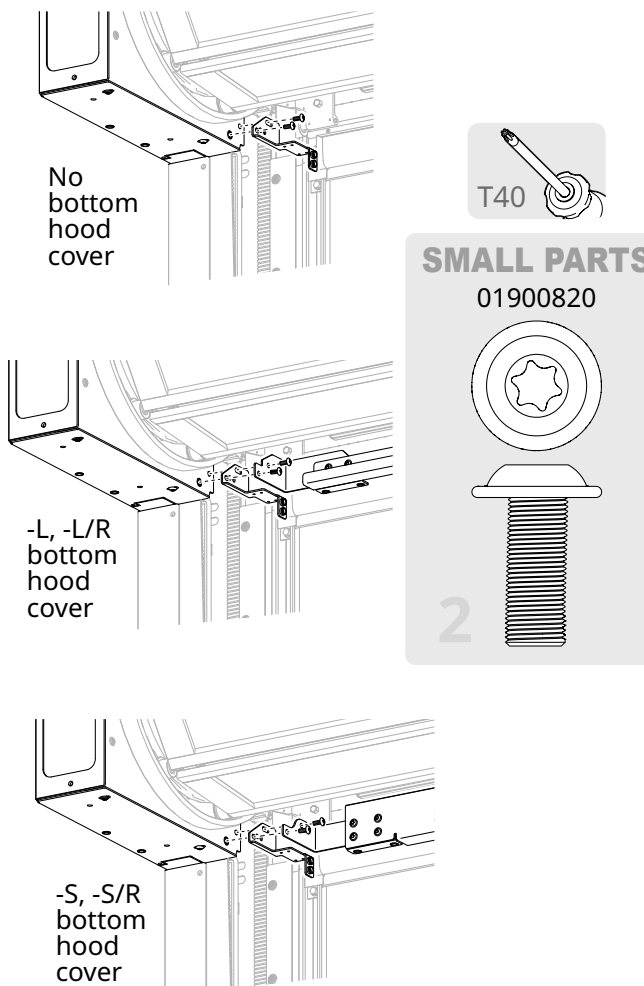

5 **Install** the wireless antenna arm onto the drive side corner bracket.

Use the hardware included with the wireless antenna arm.

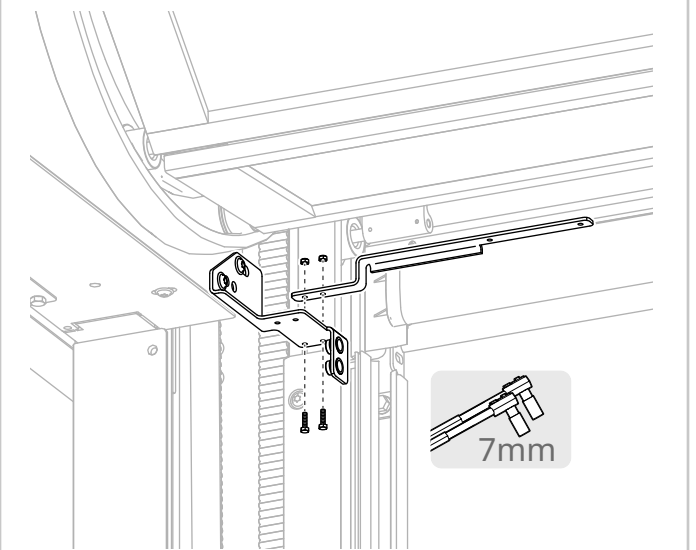

6 **Reach** into the drive side compartment and **remove** the wireless antenna and antenna bracket from the top of the motor.
Unwrap the antenna cable.

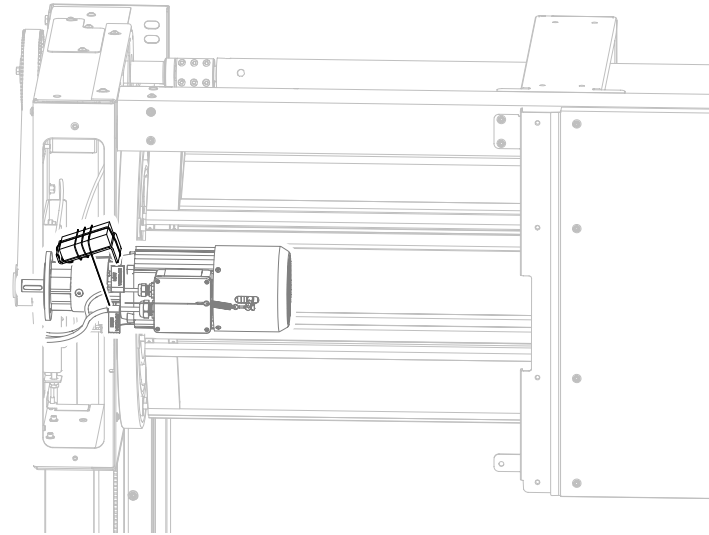

7 **Install** the wireless antenna bracket onto the arm.
Use the hardware included with the wireless antenna arm.
Secure the cable to the wireless antenna arm with cable ties.



Cable ties

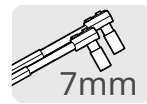
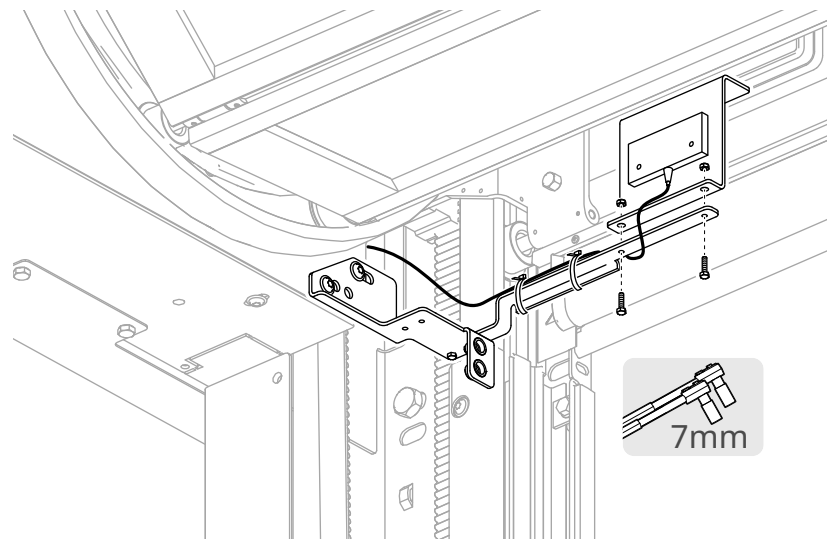

7mm

8 **-US and -US/R doors only:** route the cable to the wireless antenna around the side column and through the gap between the drive side console and the side column.
Install the bracket and **secure** the cable.



Cable ties

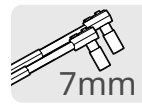
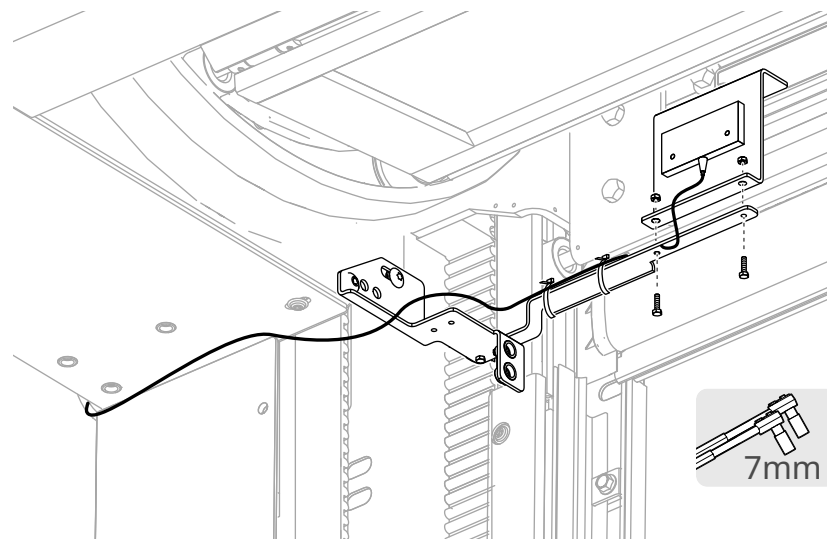

7mm

How to connect the brake release cable to the brake release lever

- 1** **Locate** the brake release cable in the console.
Loosen the retaining nut and slide it down the length of the brake release cable.

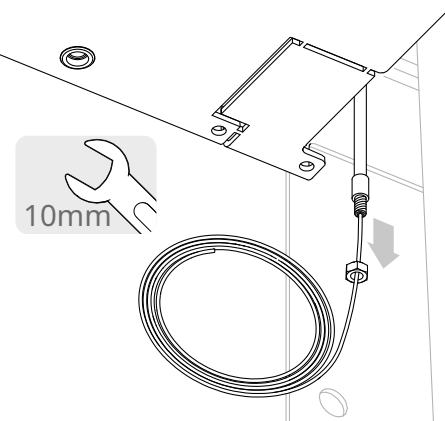

- 2** **Thread** the cable through the hole in the bottom of the console ①.
Thread the retaining nut ② up the cable and install into the bottom of the console.
Run the cable ③ down the side column to the brake release lever.

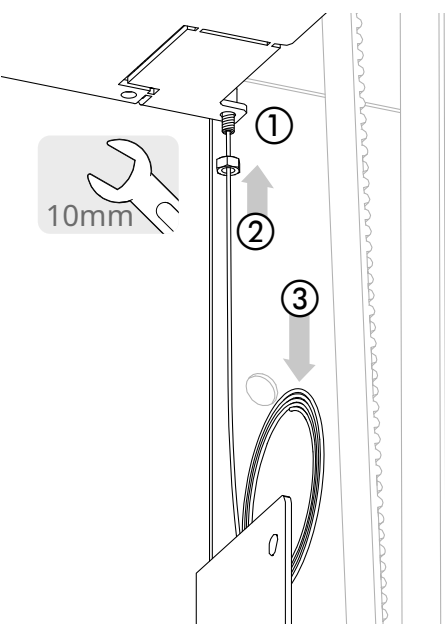

- 3** **Pull** the cable ① straight. **Allow** some slack.
Pull down the brake release lever ② to 90°.
Run the cable through the large hole in the brake release tab ③.

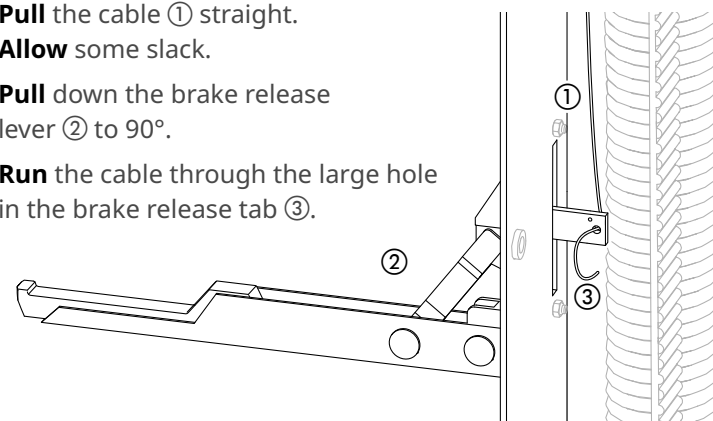

- 4** **Loosen** the screw on the cable stop clamp ④ until you can thread the cable through the clamp.
Slide the clamp against the lever tab and **tighten**.

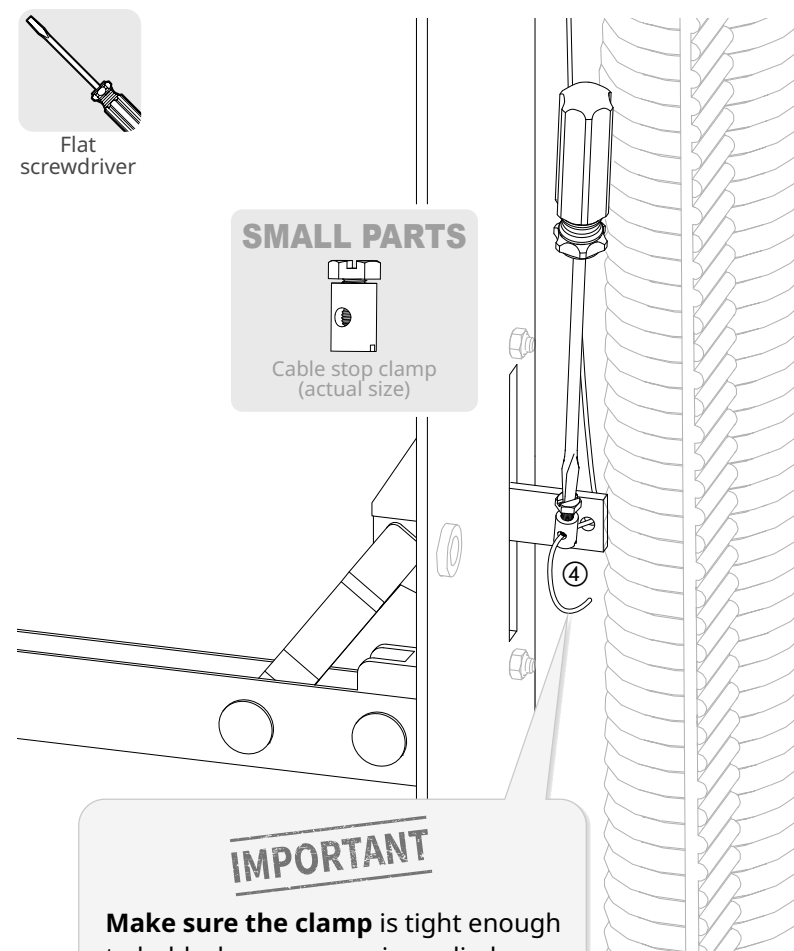

IMPORTANT

Make sure the clamp is tight enough to hold when pressure is applied.
DO NOT trim the cable until the brake release has been fully tested.

- 5** **Pull down** the brake release lever to the fully released position.

IMPORTANT

There will be some resistance when you push the lever down, but **it should not require excessive force** to reach the fully released position.
If you feel too much resistance, loosen the tension on the cable.

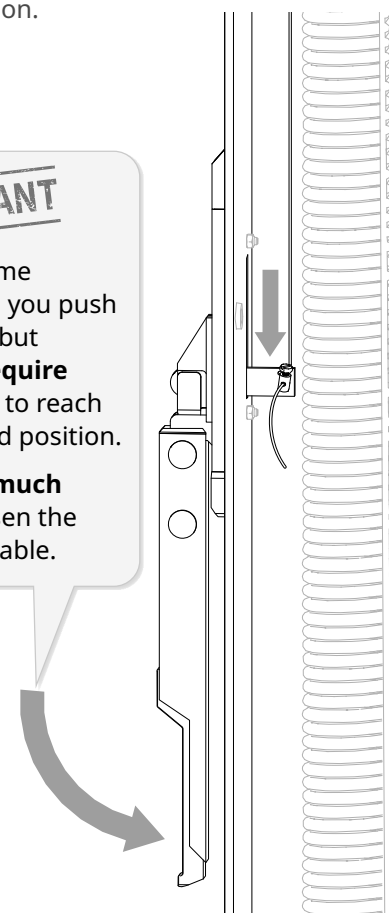

- 6** The door panel should **release** under its own weight and **drop** approximately 1/3 of the door height.
 If it does not drop, **manually pull** the door panel down to that height.

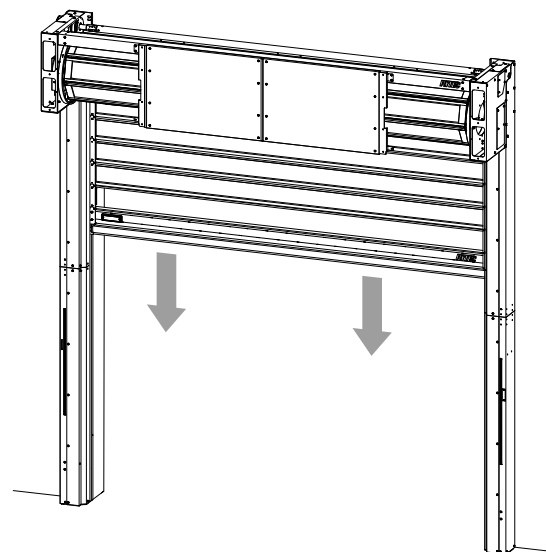

- 7** **Pull up** the brake release lever 180° to the fully engaged position.

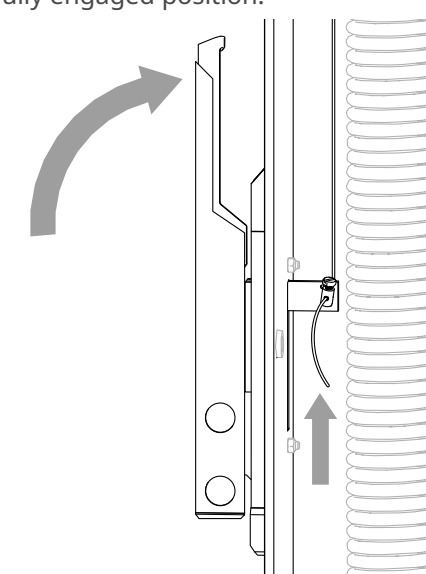

- 8** Try to **manually move** the door panel up and down.
 You should **NOT** be able to move the panel.

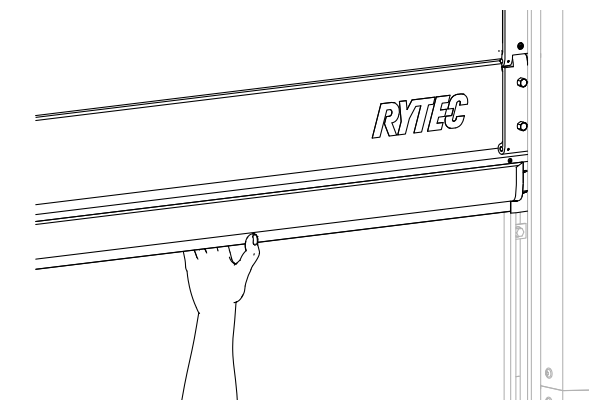

- 9** If necessary, **adjust the tension** on the cable until both conditions are met:
- The door moves freely when the brake release level is in the fully released position.
 - The door does not move when the lever is in the fully engaged position.

- 10** **Release, then reengage** the brake several times. **Test** after each time.
Make sure the cable does not loosen after multiple uses.
- If necessary, **adjust the tension** on the cable.
 - When all tests are complete, you can **trim** the cable (minimum trim length = 4").

(optional) How to install the bottom hood cover



It is recommended that you **do not use power tools** for these steps. Overtorquing screws can damage the riveted nuts that secure them.

- Locate** the spacer brackets and hardware in the small parts box.

Locate the bottom hood cover panels and bottom splice brackets (mounting brackets) in the crate.

 - L and -L/R doors may have 2, 3 or 4 panels. -S and -S/R doors may have 2, 3, 4 or 5 panels, -US and -US/R doors have 6 panels.

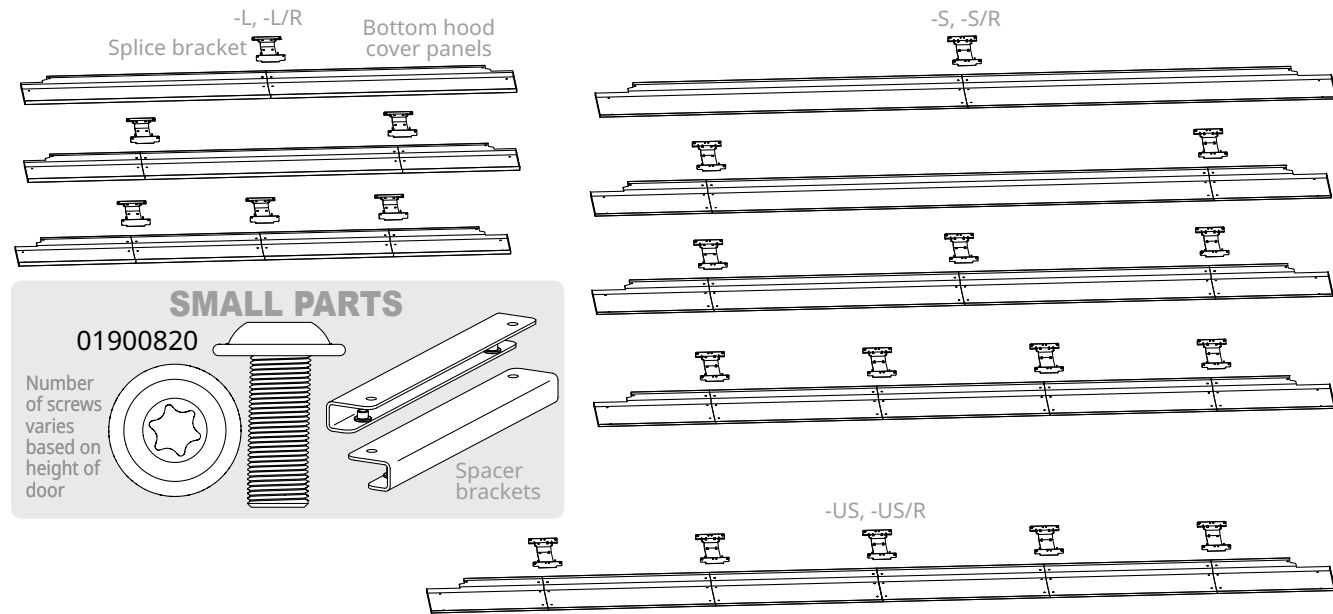

- L and -L/R doors only:** if necessary, remove all front cover panels to access the front splice brackets.

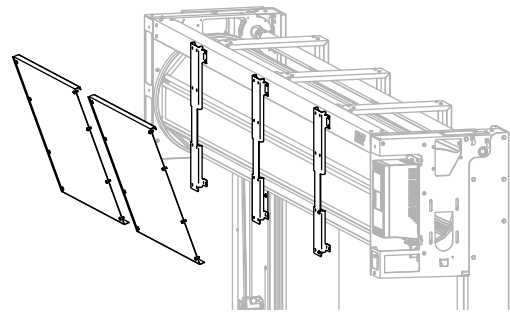
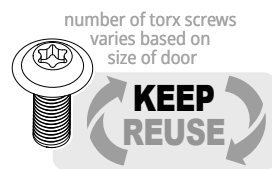

- Install** the spacer bracket from the small parts box onto the side console.

Do this on both sides of the head assembly.

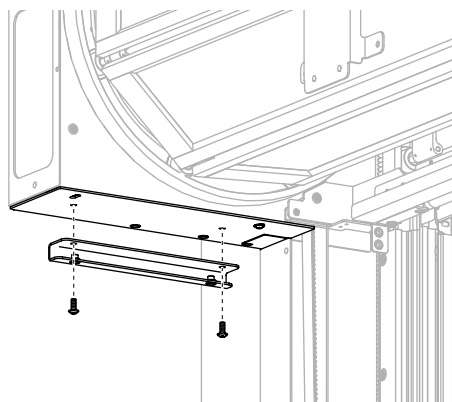
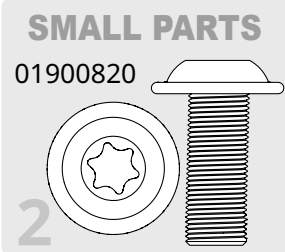

4

Install the splice brackets for the bottom hood cover panels.

- On -L and -L/R doors, the brackets attach to the front splice brackets and the bottom hood spreader.
- On -S, -S/R, -US and -US/R doors, the brackets attach to the bottom front spreader and the bottom hood spreader.

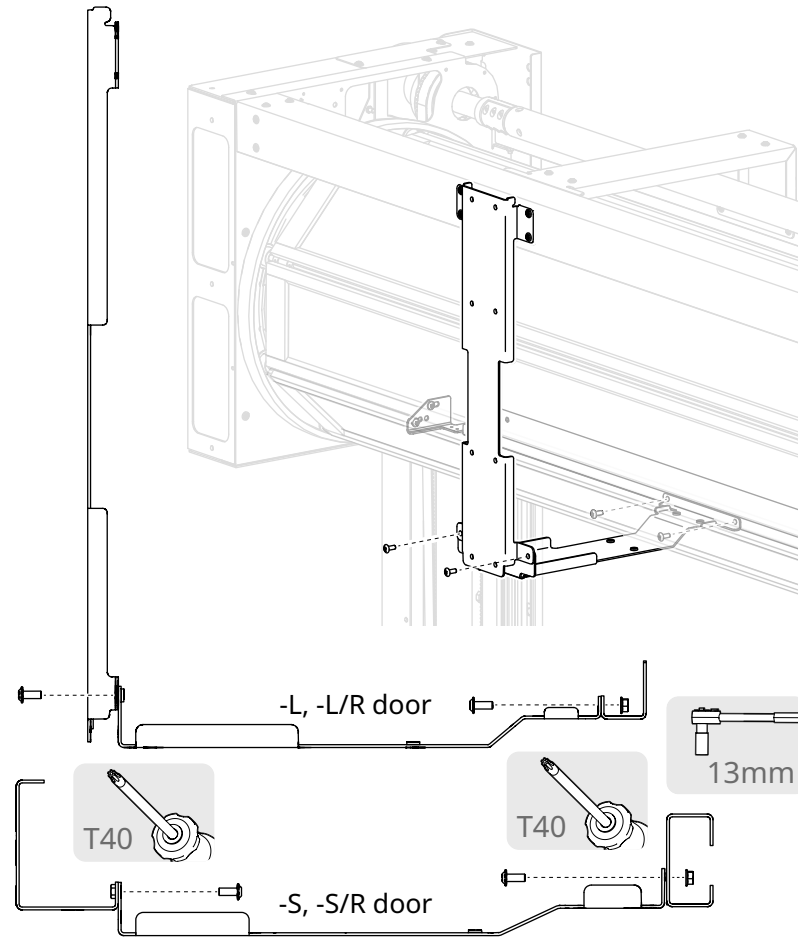

SMALL PARTS

01900820

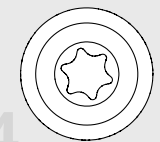

01901508

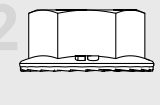

5

Install the bottom hood cover panels.

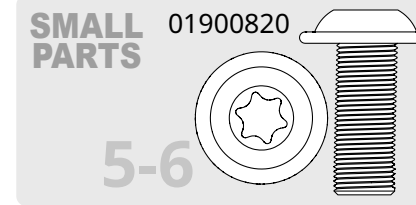
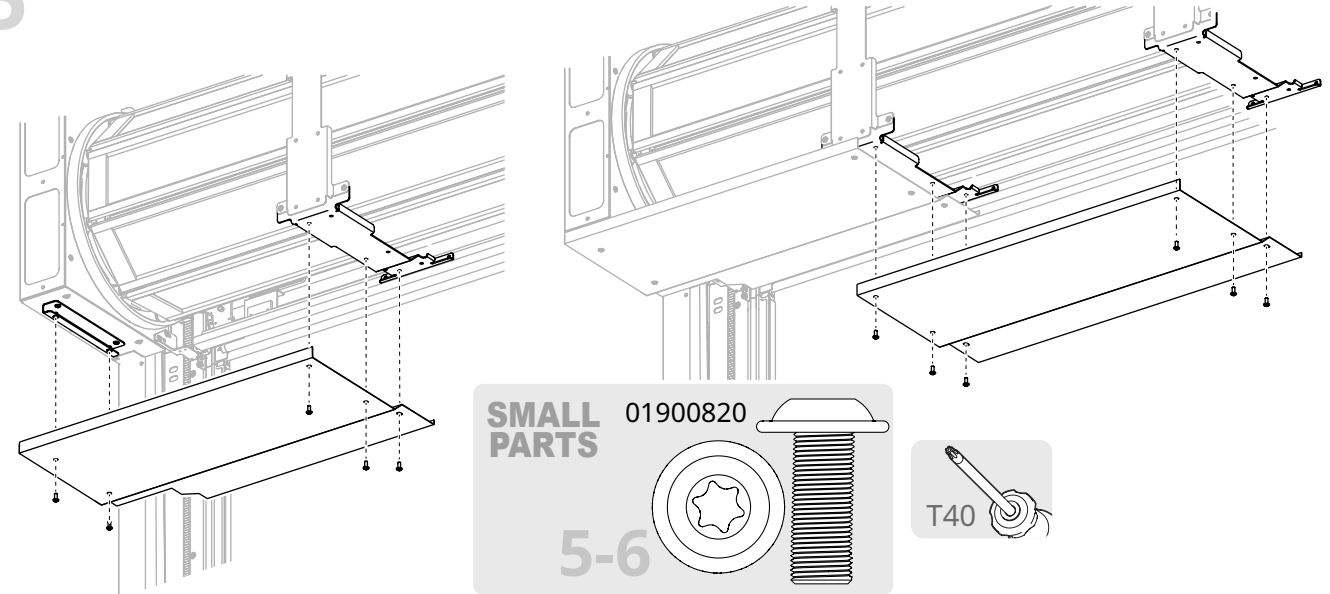

(optional) How to install the slanted top hood cover



It is recommended that you **do not use power tools** for these steps. Overtorquing screws can damage the riveted nuts that secure them.

- Locate** the top hood cover panels and splice brackets in their crate.

 - L and -L/R doors may have 2, 3 or 4 panels. -S and -S/R doors may have 2, 3, 4 or 5 panels, -US and -US/R doors have 6 panels.

Locate the flashing. There should be two long segments (three for -US and -US/R) and two short side segments.

Locate the hardware in the small parts box.

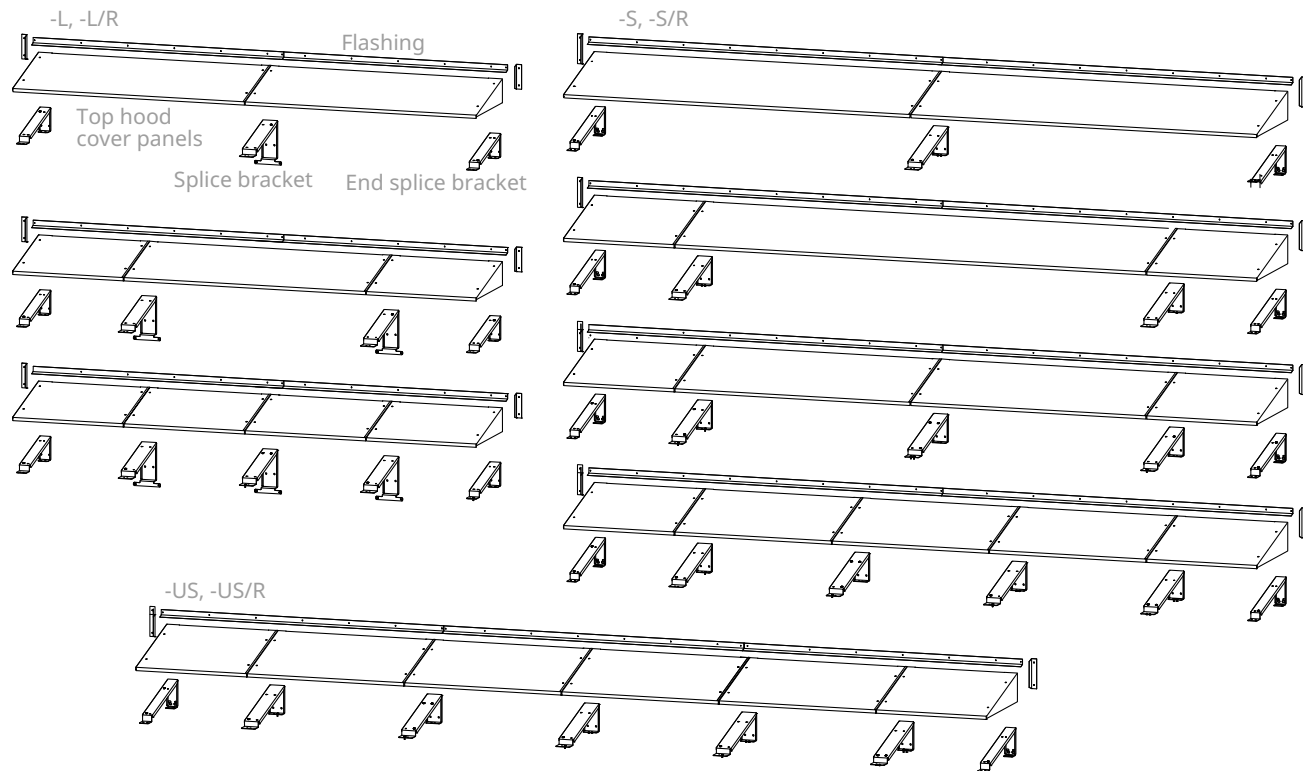

- L and -L/R doors:** install the end splice bracket.

Do this on both sides of the head assembly.

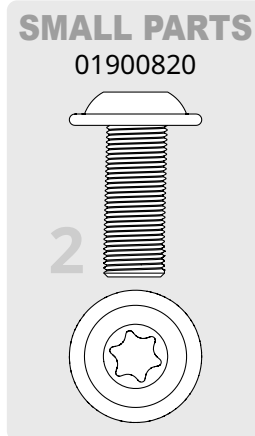
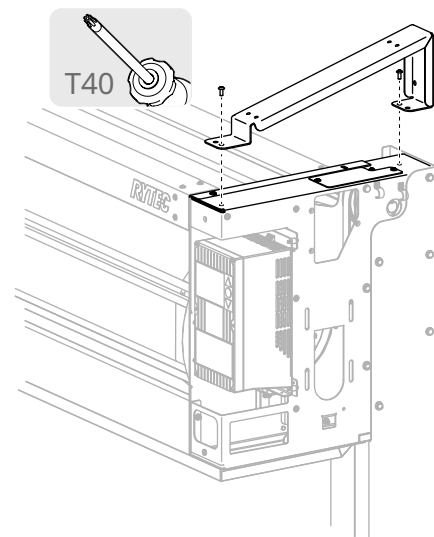

- L and -L/R doors:** install the rest of the splice brackets.

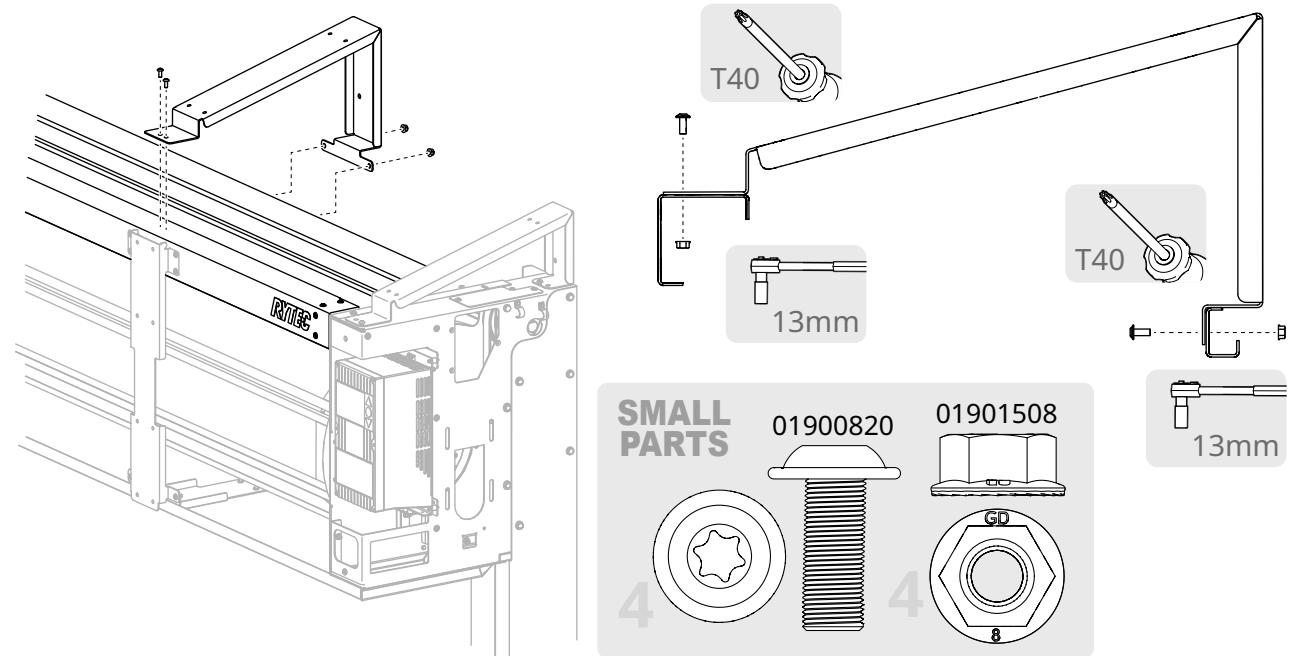

- S, -S/R, -US and -US/R doors:** install the end splice bracket.

Do this on both sides of the head assembly.

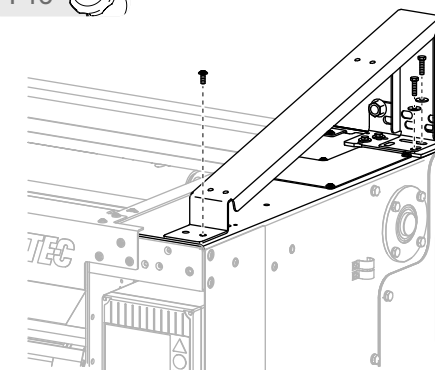
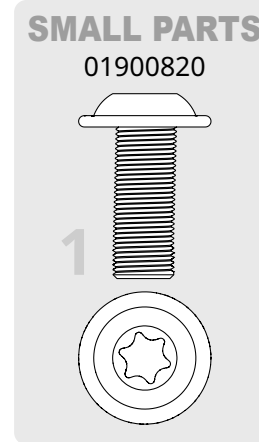

Use hardware saved in Step 10 on page 6.
Rear screw connects to **flanged nut**.
Front screw connects to **riveted nut**.

- S, -S/R, -US and -US/R doors:** finish anchoring the wall mount bracket through the splice bracket.

Do this on both sides of the head assembly.

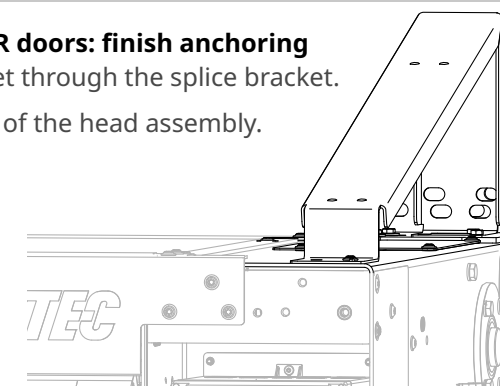
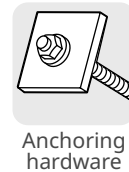

Use at least one anchor point through the splice bracket and the wall mount bracket.

6 -S, -S/R, -US and -US/R doors: install the rest of the splice brackets.

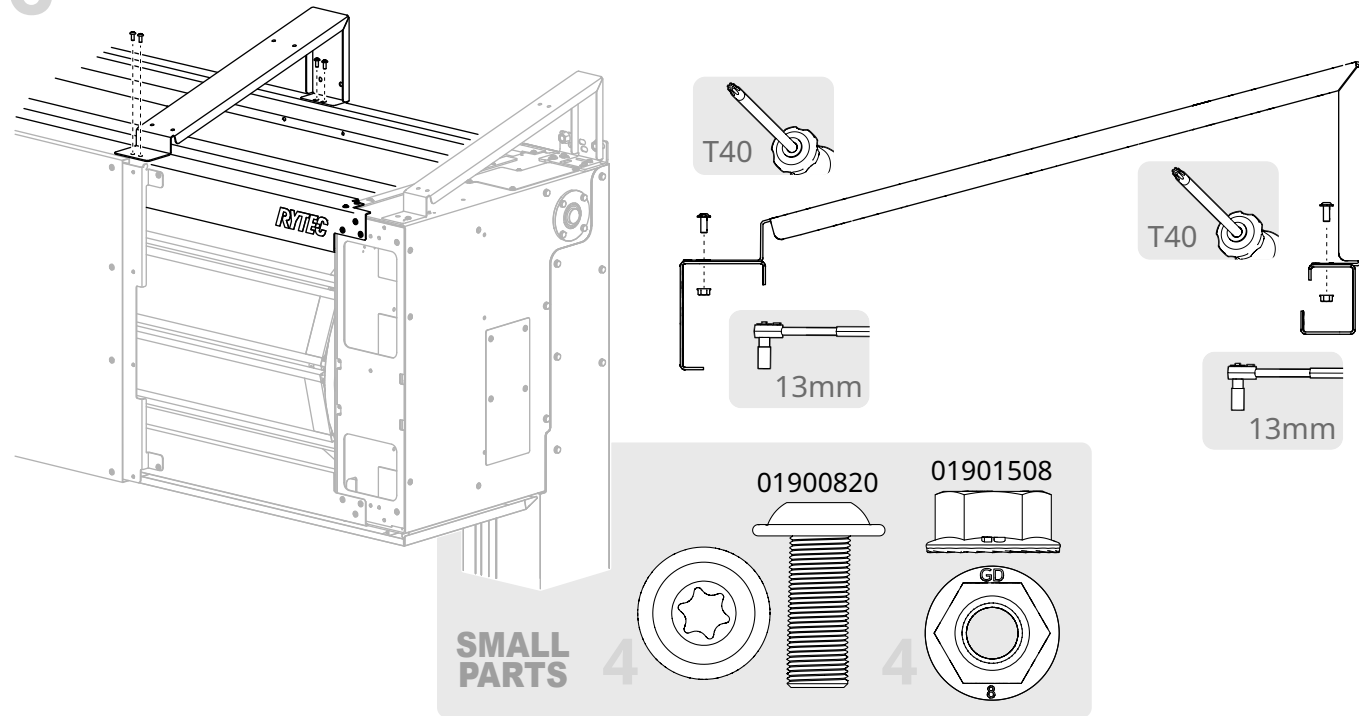

8 **Align side flashing** with top of hood cover, place flashing tight against the cover and **anchor** in place. **Do this** on both sides of the head assembly.



Anchoring hardware

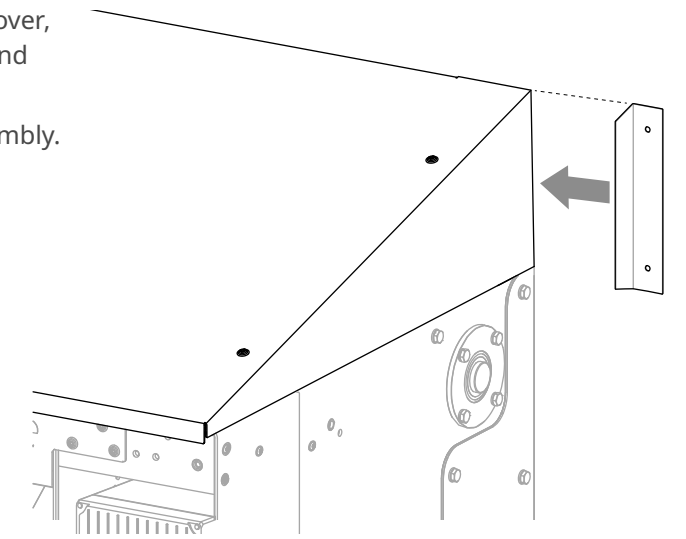

7 **All doors: install** the top hood cover panels.
 ■ **Install panels left to right:** each panel overlaps the panel to the left.

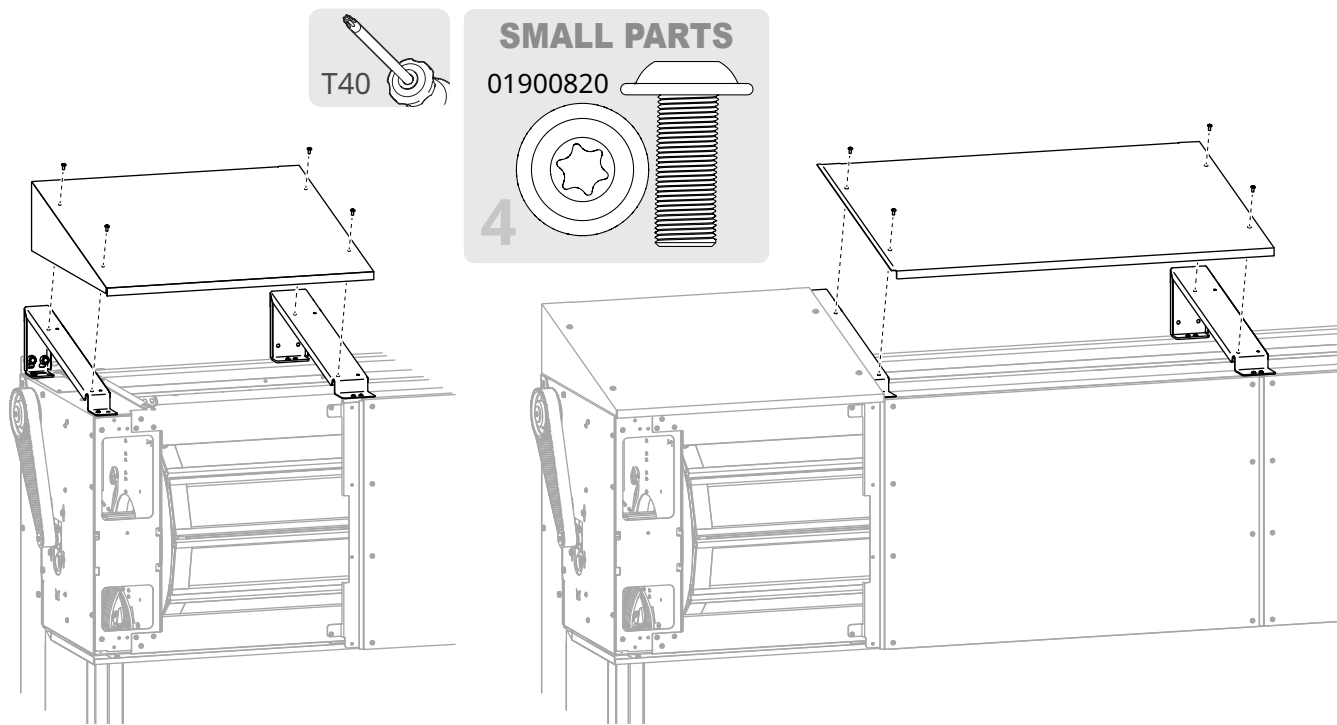

9 **Align top flashing** with end of side flashing, place flashing tight against the cover and **anchor** in place.



Anchoring hardware

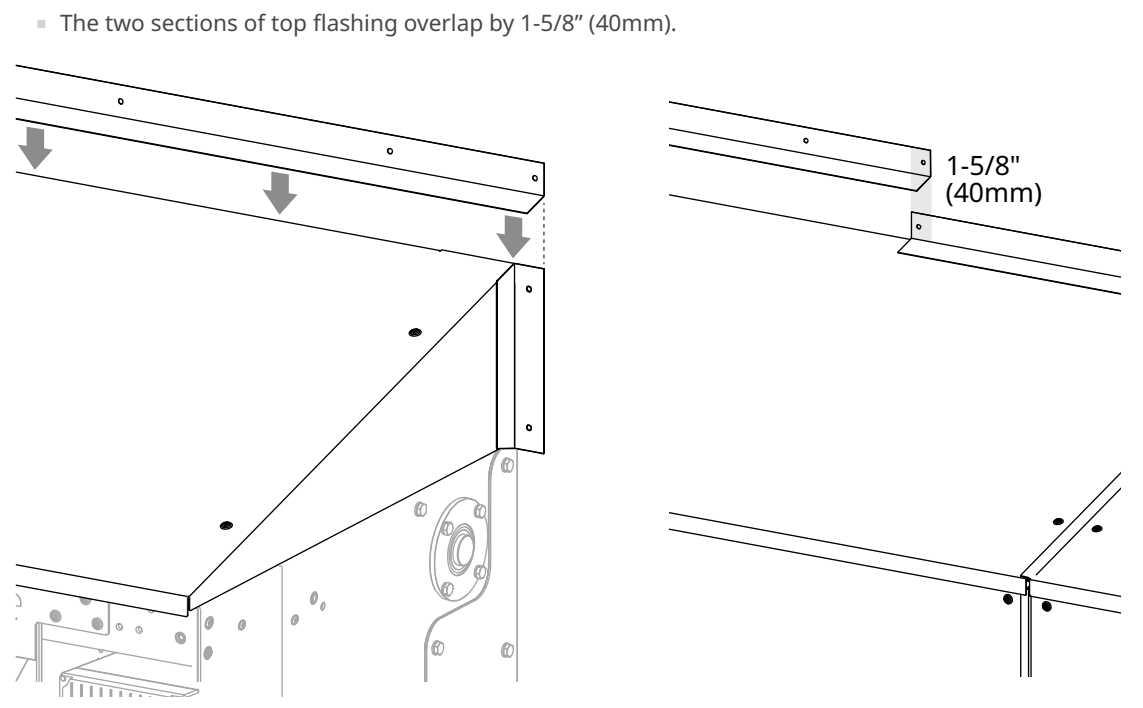

How to install the System 4 controller and wire the door

⚠ WARNING

All electrical work must meet all applicable local, state and national codes.
It is recommended that all electrical work be done by a certified electrician.

Failure to wire the door correctly could result in shock, burns or death to the people who install, use or service the door.

⚠ WARNING

The high-voltage power to the controller must be properly grounded.
Improper grounding could result in shock, burns or death to the people who install, use or service the door, as well as catastrophic motor failure.

- **If the service is floating, ungrounded or open delta type power,** an isolation transformer must be installed.
- Metal conduit entering the bottom left of the control box contacts the metal protection ground plate inside the controller. **If non-metallic conduit is used,** a protection ground conductor must be used.

IMPORTANT

The System 4 installation must meet all of the standards and follow all of the steps shown in these instructions. Failure to do so voids the warranty for the door.

- **The high-voltage and low-voltage conduits must be separated** by a distance that meets all applicable federal, state and local codes and regulations.
- **Wires must be cut to length.** Do not loop wires or leave excess length untrimmed.
- **Use shielded wiring** where indicated in these instructions.
- **If you splice wires:**
 - **You must use** the same gauge wire for the entire length. Gauge is listed in the steps in these instructions.
 - **All spliced field wiring** must maintain the voltage and temperature rating supplied by Rytec.

Contact Rytec technical support at 800-628-1909 or email helpdesk@rytecdoors.com before starting the installation if you cannot meet any of these standards or have questions about how to implement them.

Before you begin

1 Make sure you have all supplies and tools.

Supplies that you provide

Tools you will need

2 Check the job site.

- **The ambient temperature** must be between **-4°F** and **149°F** at all times. Lower temperatures require a control box heater. Contact Rytec technical support for more information.
- **NOTE: for freezer doors,** the controller and fused disconnect must be mounted on the warm side of the door.
- **The mounting surface** for the System 4 controller and fused disconnect must be structurally sound and free of mechanical shock and vibration.

3 Install the high-voltage power supply.

- **Provide a high-voltage power supply** that matches the electrical spec for the System 4 controller.
- **A fused disconnect is recommended.** Fuses must meet NEC code for FLA listed on the electrical spec for the System 4 controller.

4 Make sure the high-voltage and low-voltage cables from the head assembly of the door are separate. **Cables may be routed** through the top ① or bottom ② port at the back of the belt guard cover.

INSIDER'S TIP

Label the controller end of the cables. **Label them again** if you cut or trim them.

High Voltage

Motor power

Wires: White, Red, Green, Black

Low Voltage

Brake

Wires: White, Black

Pathwatch (1 or 2 cables)

Wires: White, Black, Red

Encoder

Wires: White, Yellow, Pink, Gray, Red, Green, Blue, Brown

X-10 junction box

Wires: White, Yellow, Gray, Orange, Purple, Red, Green, Blue, Brown, Black

How to install the System 4 controller

- 1 **Open** the System 4 controller box and get the controller and ferrite filters. **Loosen** screws on the control box and **open** the cover panel.

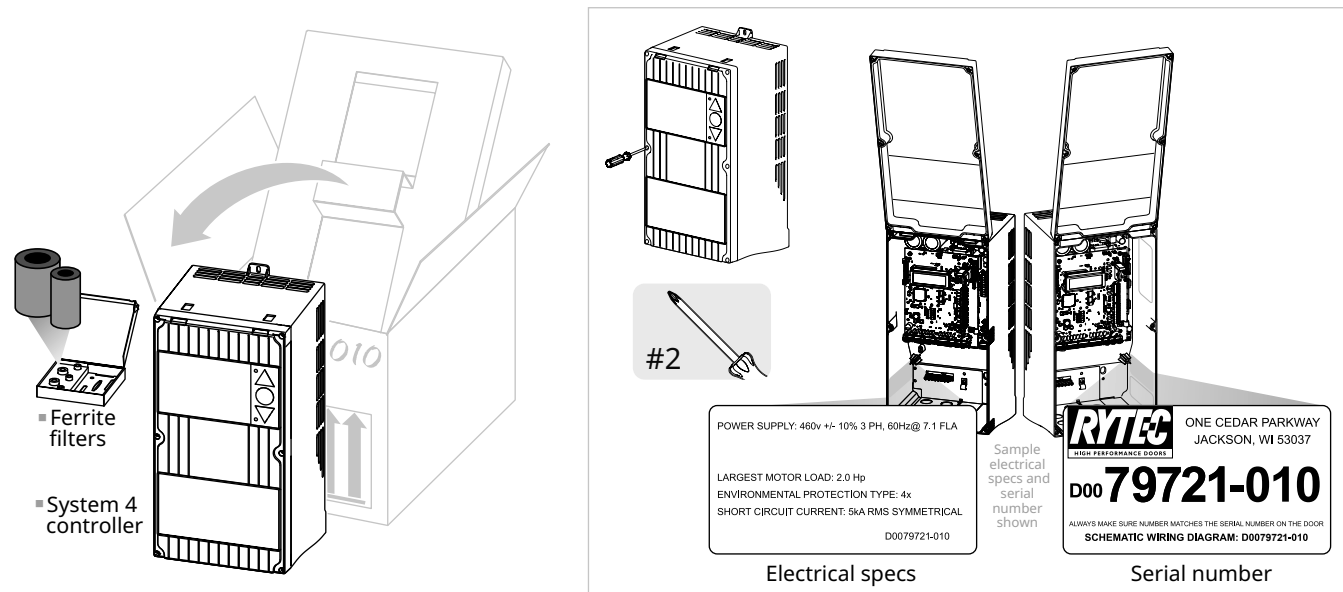

Verify that the serial number and electrical specs for the controller match the door.

- 2 **Install** the control box onto the wall using the hardware you have supplied.

- 3 **Drill** holes through the bottom of the control box for the conduit.

IMPORTANT

- **Conduit must enter through the bottom of the control box.** Drilling holes in the **front, back, top or sides** of the control box voids the warranty.
- **High-voltage wires** must enter through the left side of the box bottom.
- **Low-voltage wires** must enter through the right side of the box bottom.
- **Holes must be drilled.** The indentations in the box bottom are not knockouts.

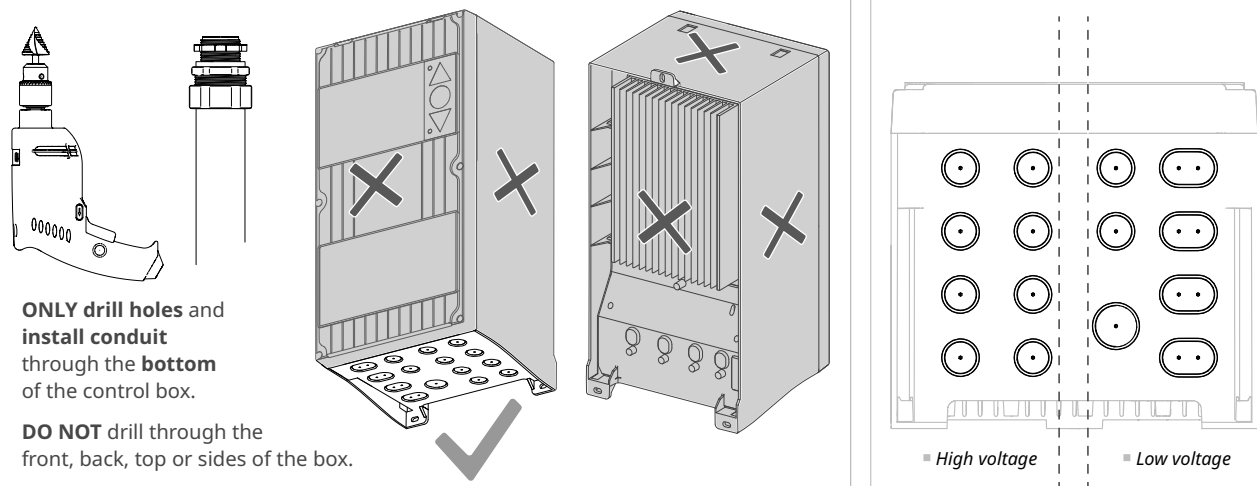

How to install the high-voltage wiring

WARNING

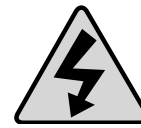

Set the disconnect switch to the OFF position and perform a lockout/tagout of the high-voltage disconnect before installing wiring to the controller. Do not set the disconnect switch to the ON position until the wiring installation is complete and the controller is fully earth grounded per instructions.



Failure to comply could result in shock, burns or death.

- Find the schematics** for the door in the red document envelope. **Check the crate and small parts boxes** for accessories such as activators or safety devices and any schematics included with them. If the schematics indicate the door has non-standard wiring, **follow the schematics** instead of this manual.

IMPORTANT

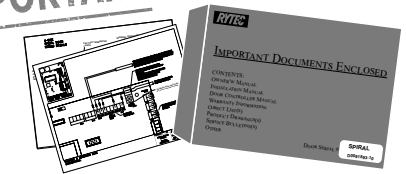

- 1 **Connect** the supply voltage wiring from the disconnect.



12 AWG

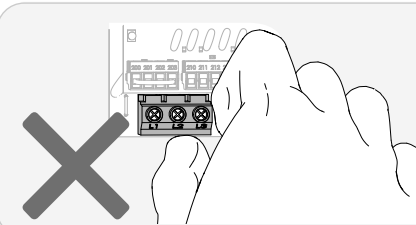

Do not try to remove the green terminal block from the circuit board. It is fixed in place and will break.

Maximum torque for all screws is 2.5 in-lbs.

Place one large ferrite filter around all three wires, and one small filter around each individual wire.

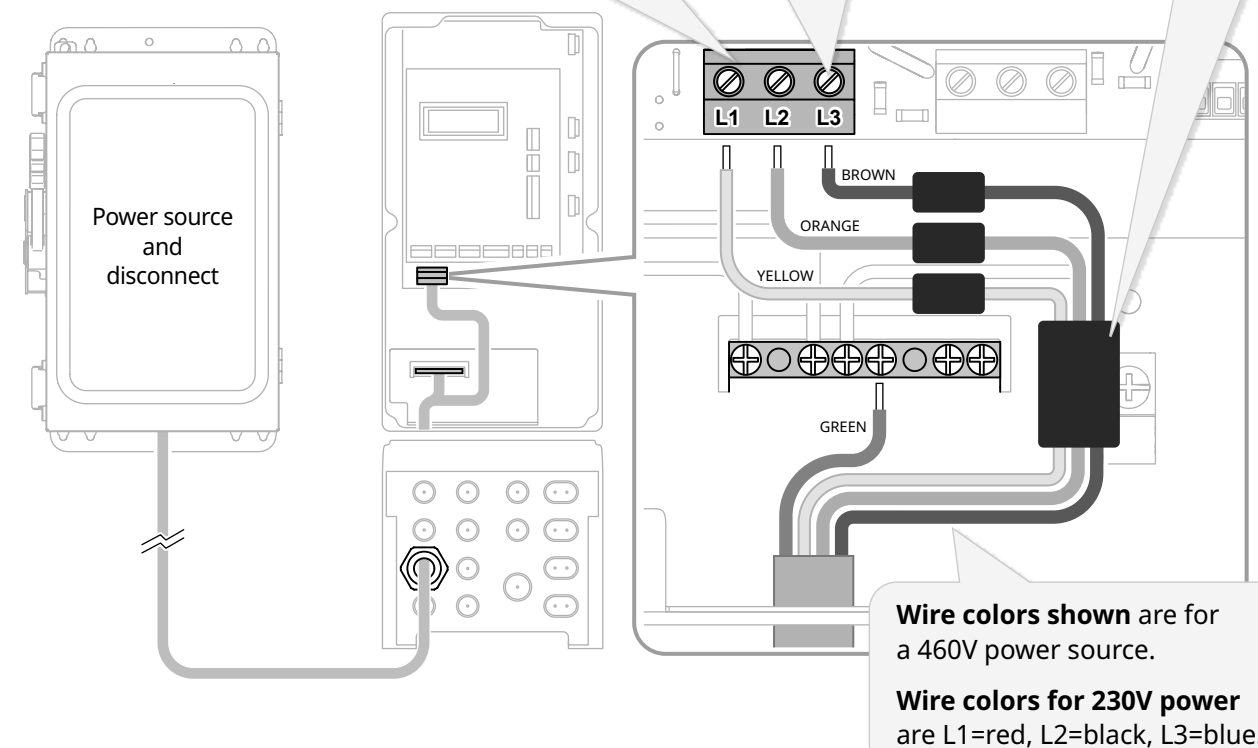

Wire colors shown are for a 460V power source. Wire colors for 230V power are L1=red, L2=black, L3=blue.

2 Connect the high-voltage wiring from the motor.
Shielding: braided copper mesh and drain wire

16 AWG

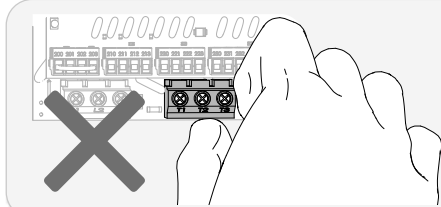
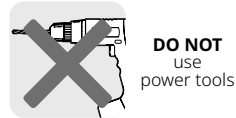

Do not try to remove the green terminal block from the circuit board. It is fixed in place and will break.

Maximum torque for all screws is 2.5 in-lbs.

Place one large ferrite filter around all three wires.

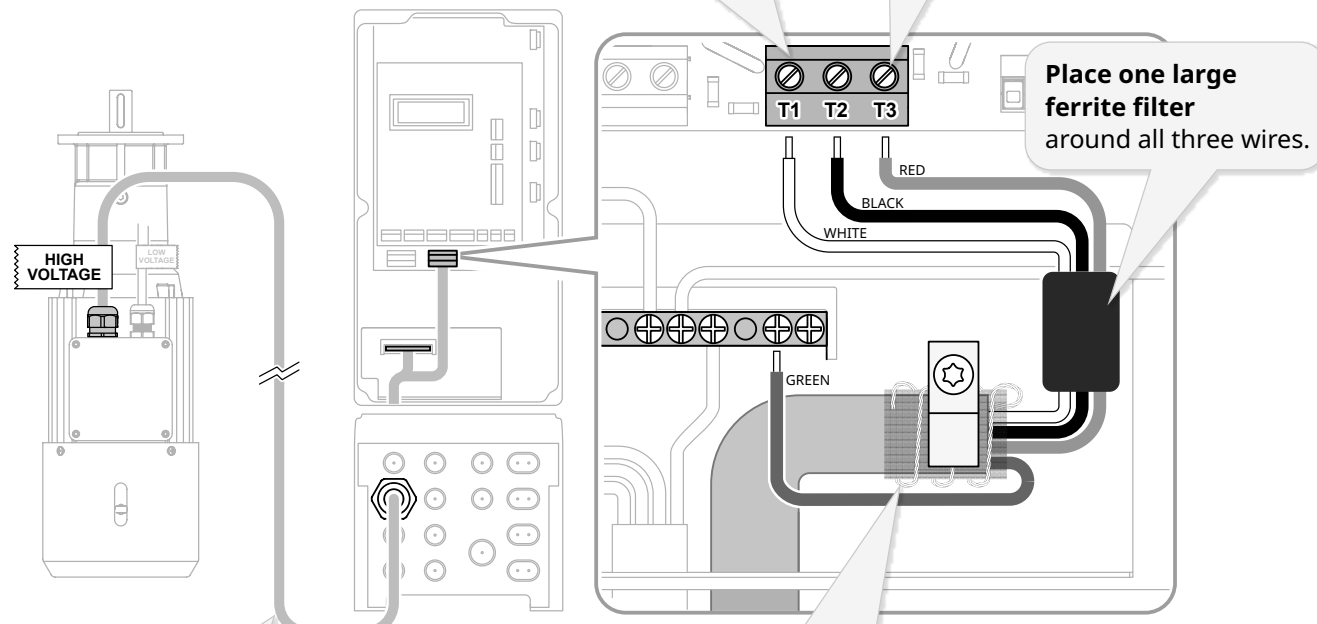

Maximum wire length between motor and controller: 100' (one hundred feet).

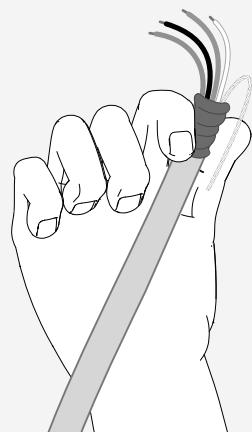

The **shield** (braided copper mesh) and **drain wire** (bare metal) must be in contact with the **P-clip**.

To ensure a tight contact:

1. Loosen the P-clip.
2. Strip high-voltage cable jacket to expose braided shield, then pull back shield and wrap drain wire around it.
3. Run wires, shield and wrapped drain wire under clip.
4. Tighten clip.
5. Trim excess drain wire.

How to install the low-voltage wiring

IMPORTANT



- Low-voltage wires can be run in the **same conduit**.
- All low-voltage wiring must be 24 VDC+ only, installed per NEC to Class II power supply requirements.
- Maximum torque for all System 4 controller screws is **2.5 in-lb.** **DO NOT use power tools.**

1 Connect the brake wiring from the motor.
Shielding: unshielded

18 AWG

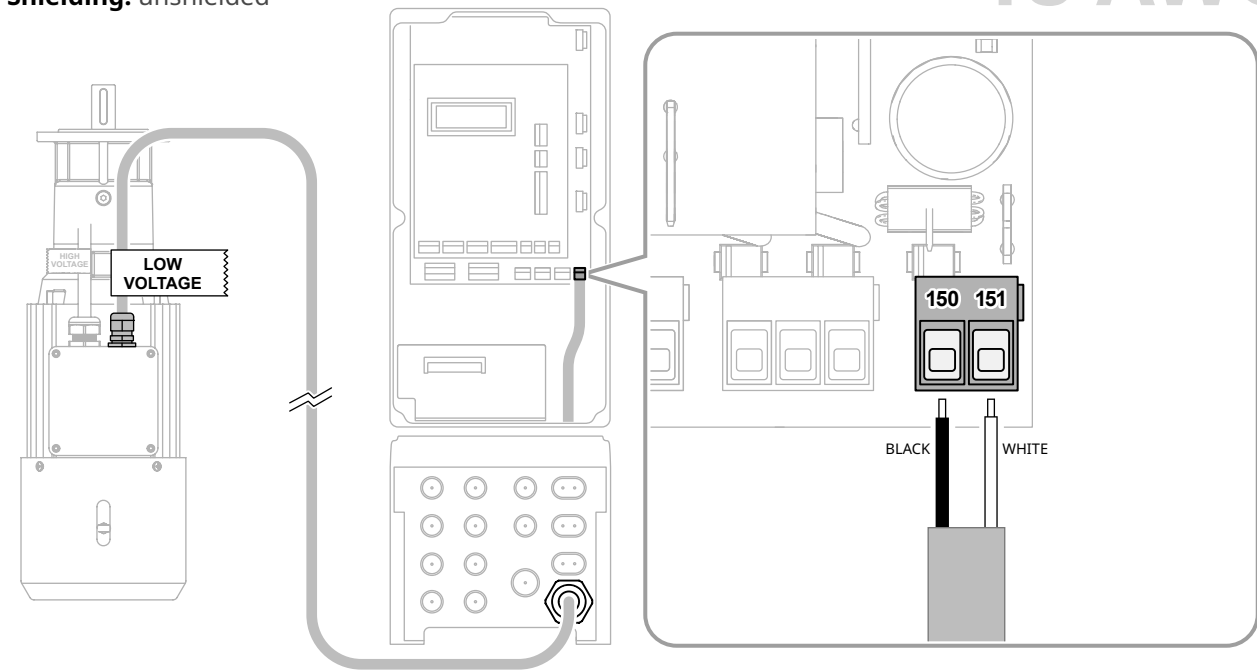

2 Connect the wiring from the Pathwatch LED strips.
Shielding: unshielded

18 AWG

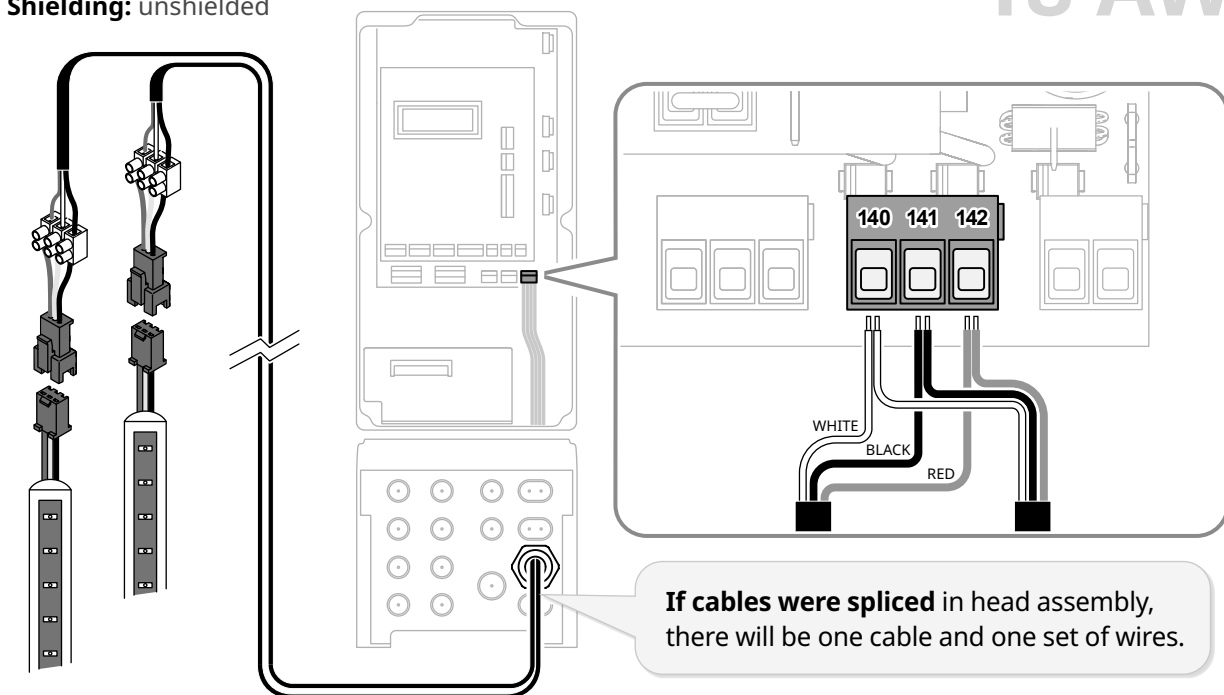

If cables were spliced in head assembly, there will be one cable and one set of wires.

3 Connect the wiring from the encoder.
Shielding: metal foil and drain wire

24 AWG

IMPORTANT Encoder wiring must not be spliced unless you have consulted with Rytec technical support at 800-628-1909.

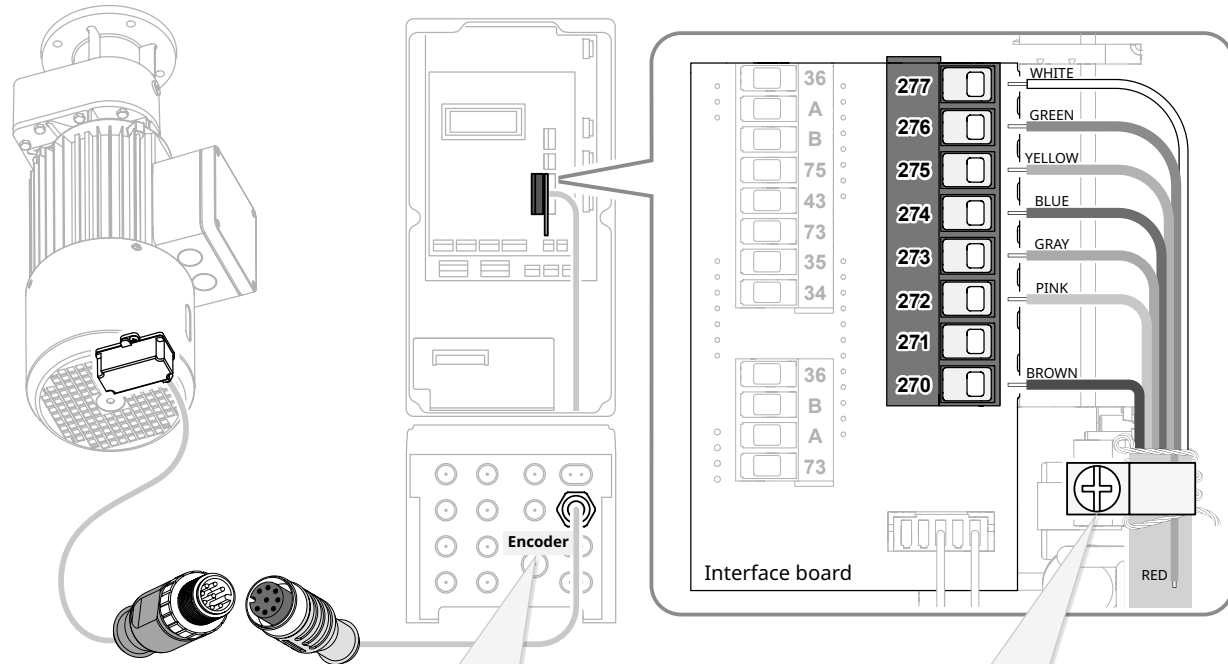

Mark controller end of cable as "Encoder"

- The **drain wire** (bare metal) must be in contact with the **P-clip**.
- To ensure a tight contact:**
1. Loosen the P-clip.
 2. Strip encoder cable jacket to expose wires.
 3. Trim and bend red, pink, gray and blue wires. Tape to jacket.
 4. Wrap drain wire around jacket and unused wires.
 5. Slide cable under P-clip and tighten. **Make sure there is maximum contact** between clip and drain wire.
 6. Trim excess drain wire.

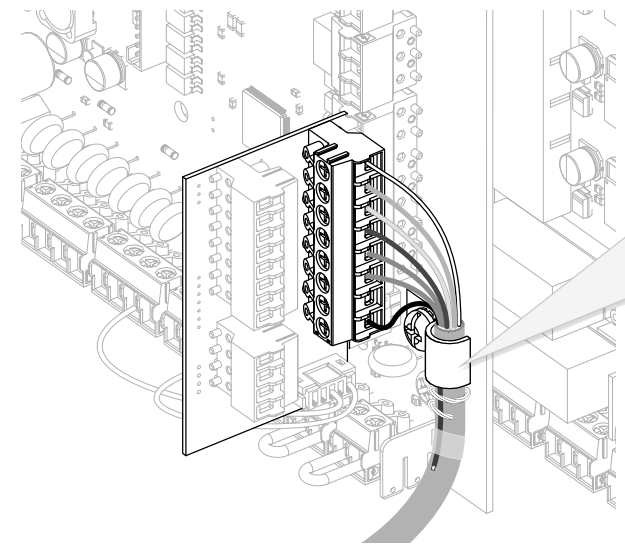

4 Connect the wiring from the X-10 junction box.
Shielding: unshielded

24 AWG

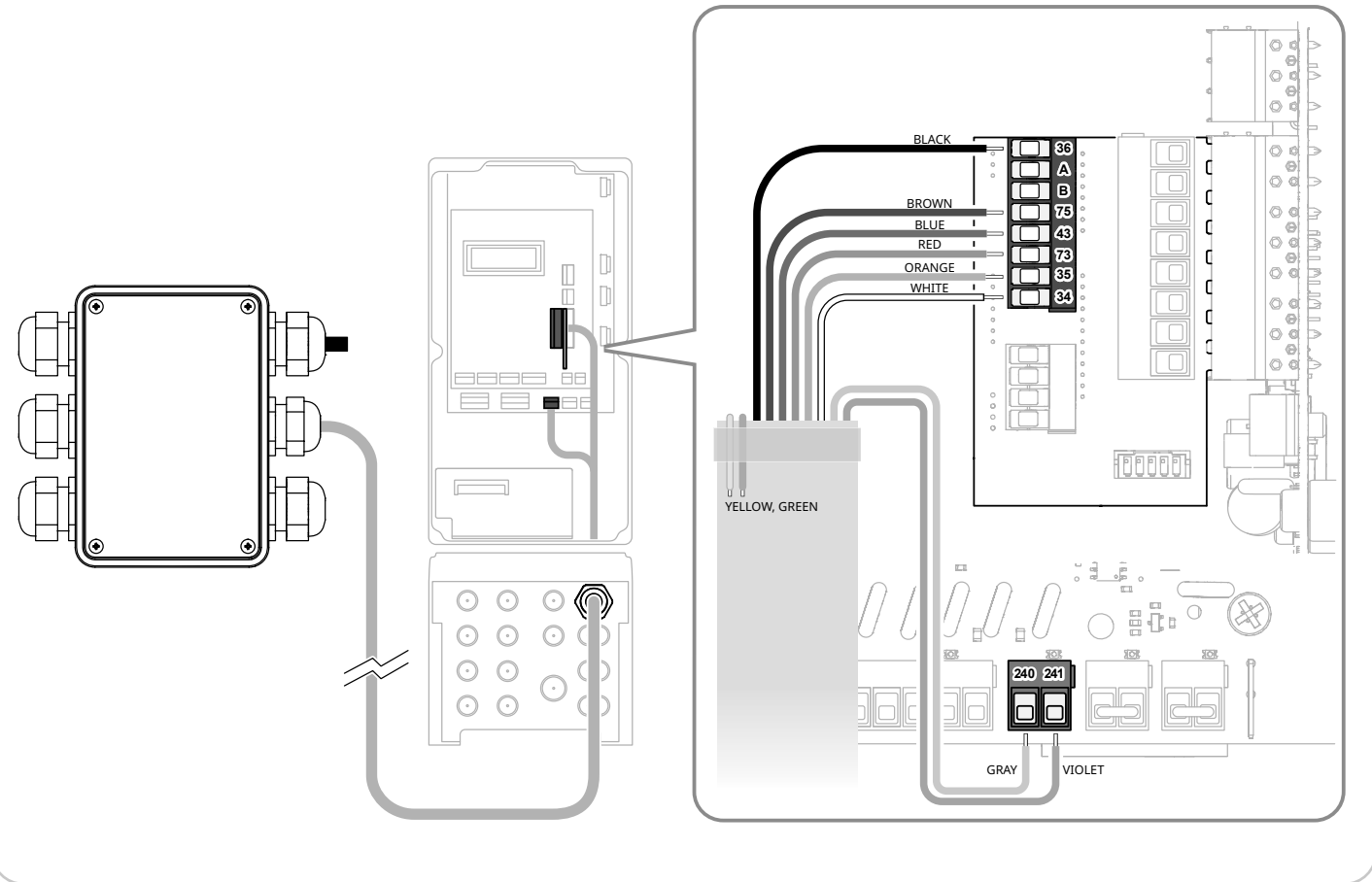

Before powering up the door

⚠ WARNING

It is recommended that this pretest be done by a certified electrician.

- 1 **Make sure** the power to the door is correct.
 - **Open** the System 4 control box and check the power supply listed on the label inside.
 - **Test** the voltages at the disconnect. Test leg to leg and leg to ground.
 - If power is correct, **power up** the door and start the set limits sequence.

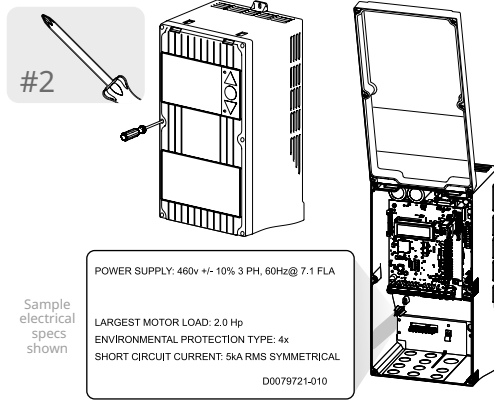

How to set limits and test the door

⚠ CAUTION

Make sure that people and vehicles do not pass through the open doorway until the automatic calibration is complete. The door can open or close unexpectedly, resulting in injury.

The Controller Display

Access level

- O** = Operator level
- S** = Service level
Accesses more parameters
- R** = Rytec level
*Accesses all parameters
Requires password from technical support*

Parameter name

P: Password 0

001= 1979 Cyc

Parameter number
All three digits are hexadecimal

Parameter value
? = value being changed
✓ = change saved

Blinking cursor
On left side of display: *press arrows to change parameter number*
On right side of display: *press arrows to change parameter value*

The Controller Controls

UP Arrow

- Press to increase a value or parameter number
- Press and hold to increase values or parameter numbers quickly

RESET Button

- Press to toggle the flashing cursor between parameters and values
- Press and hold to save changes to a value

DOWN Arrow

- Press to decrease a value or parameter number
- Press and hold to decrease values or parameter numbers quickly

Icon key

Press

Press and hold

Press UP or DOWN arrow, as needed

NOTE: The System 4 display uses hexadecimal numbers to number parameters and for some values.

The display uses the ten numeric characters (0-9), plus six letters (A-F), which represent the values from 11 through 16.

In some cases it will be necessary to press the UP arrow sixteen times to change a value from 0000 to 0010.

Make sure the protective film has been removed from both light curtains before turning on power to the door.

Do This **Result**

1 Turn on power to controller

The sequence starts. Scrolling message: Press Reset button to begin

Result

! Synchron. !
_0 Press Reset

2 1X to start sequence

Scrolling message: Hold Reset button if position OK

Result

➔ To Open Pos.
_0 Hold Reset

IMPORTANT Interrupt the set limits sequence and run the tests in *What to test after powering up the door* on the next page.

3 **Resume** the sequence and set the open position.

until open height is correct

Result

➔ To Open Pos.
_0 Hold Reset

The bottom of the door panel should be above the lintel (top of the door opening) and below the point where the door panel stops automatically.

Do This **Result**

4 until "Open Limit Set" screen displays

Result

Open Limit Set
_0 _

when quality check is complete, you see these screens:

LGx Qual. Check
_0

! Synchron. !
_0 Press Close

Scrolling message: Press Close button to begin

5 1X to lower the door panel

Result

Search Edge
_330_Auto Close

the door panel stops when it reaches the bottom of the light curtain, then you see:

!Auto Calibrate!
Press Open butto

6 1X to start auto-calibration

Result

Act1 = 45Sec
Object 232

Door Is Closing
1515 Limit Corr.

Spiral
[xxx] Cycles

- The door opens and closes automatically up to 12 times.
- The controller automatically sets the close limit position while the door calibrates.
- When calibration is complete, the door switches to Run mode.

IMPORTANT The door may not open or close completely during automatic calibration. This is normal.

When calibration is complete, the door will open and close correctly.

You can now **test the door**.

What to test after powering up the door

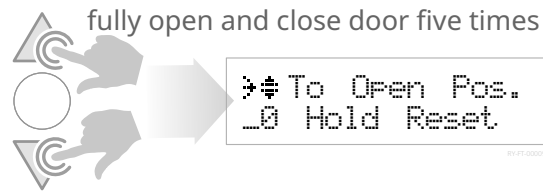

Press and hold the arrows to fully open, then fully close the door five (5) times.

1 Does the door panel move in the right direction?

Test: The direction of the door should match the direction of the arrow on the controller.

Yes: no action is needed.

No: follow the steps in *How to reverse the rotation of the motor*.

2 Is the door panel level and plumb?

Test: laser the door along the seal between two door panel slats.



Laser level

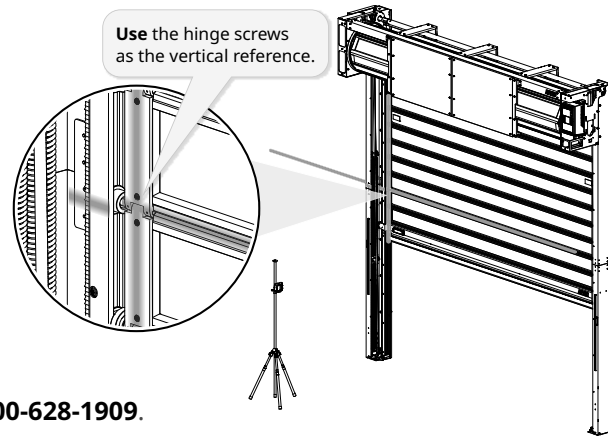

Yes: no action is needed.

Panel is not level: follow the steps in *How to adjust the secondary drive belt*.

Panel is not plumb: contact Rytec technical support at 800-628-1909.

3 Are the drive belt pulley assemblies level?

Test: make sure the secondary drive belts in both side columns are centered in the pulley assemblies after the door has been opened and closed several times.

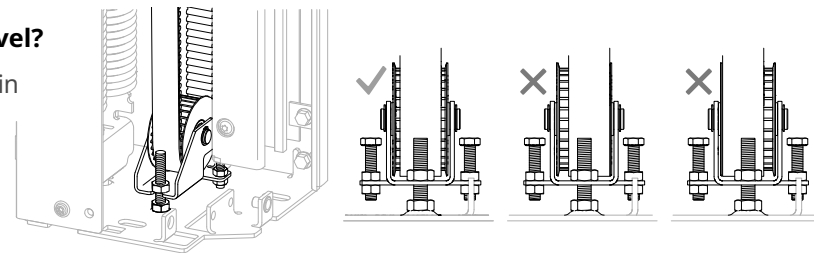

Yes: no action is needed.

No: follow the steps in *How to level the baseplate pulley assembly*.

4 Is the manual brake release operating correctly?

Test: pull down the lever to 90° to manually release the brake, then push the lever back up to reset it.

Release operating correctly: when the lever is down, the door panel moves freely and the controller displays an F211 Emergency Stop error. When the handle is reset, the controller displays Door held open and you can close the door by pressing the DOWN arrow. **No action is needed.**

Release NOT operating correctly: the F211 Emergency Stop error stays on when the lever is reset, and the door cannot be closed. **Follow the steps in How to adjust the proximity sensor.**

5 Is the door operating correctly?

Test: listen for grinding, whining or excessive motor noise. Watch for changes in speed or excessive movement of the motor or drum

Yes: no action is needed.

No: contact Rytec technical support at 800-628-1909.

How to reverse the rotation of the motor

First: set the controller to Parameter mode and access Service level parameters

Do This	Result	Do This	Result
1 until the parameter screen displays		4 16X to set value to hexadecimal 10	
	You are in Parameter mode. Go to parameter P:999.		Set the value to 10 (Service level password).
2 2X to reach parameter P:999		5 until question mark changes to checkmark (value saved)	
	The parameter P:999 screen displays.		The Service level password is saved.
3 1X to move cursor to the right (edit value)		6 1X to move cursor to left (parameters)	
	You can now change the value of parameter P:999.		You can now go to parameter P:130.

Next: navigate to parameter P:130 and change the value

Do This	Result	Do This	Result
1 until parameter displays		3 press either arrow to change value	
	Value is either 0 or 1.		Change the 0 to 1, or change the 1 to 0.
2 1X to move cursor to the right (edit value)		4 The new value is saved.	
	The value is either 1 or 0.		The new value is saved.
5 until the "To Open Pos." screen displays		5 until the "To Open Pos." screen displays	
	Reset the limits for the door.		Reset the limits for the door.

How to adjust the secondary drive belt

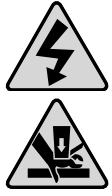

⚠ WARNING

Do not perform this procedure until the power disconnect is in the OFF position and a lockout/tagout is complete.

Contact with high-voltage wires, or the door being activated unexpectedly, can cause death or serious injury.



1

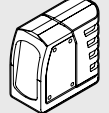

Laser level

IMPORTANT

Always adjust the belt to **lower** the side of the door panel that is **higher**.

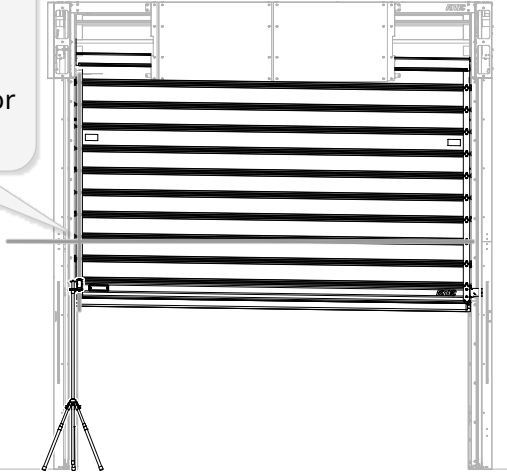

2

Loosen the top front nut on the baseplate pulley assembly until there is noticeable slack in the secondary drive belt.

- It should not be necessary to remove it from the mounting bolt.

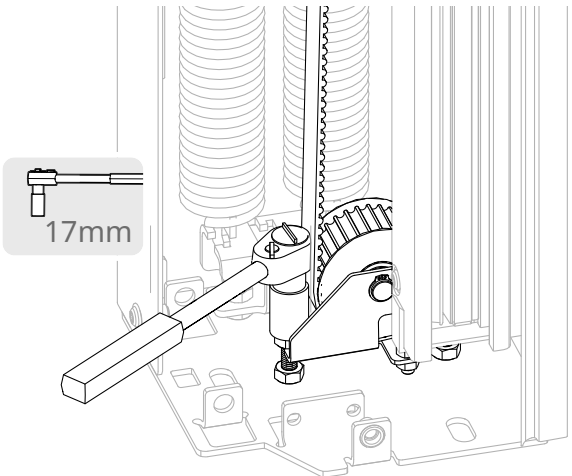
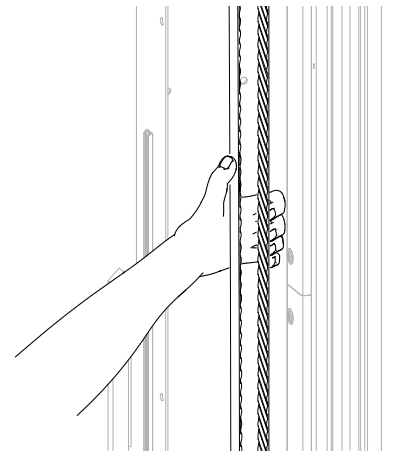



3

In the head assembly, **“jump” the secondary drive belt** one notch in the pulley.

IMPORTANT Adjust the belt **one tooth at a time**, then recheck level.

Push up slack to create a “wave” in the belt and hold it against the pulley.



Press belt up and in until teeth drop into the next notch on pulley.

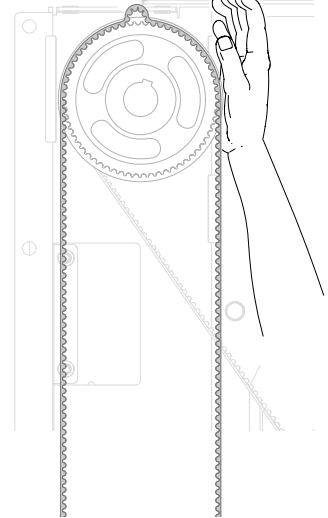

Push “wave” around top of pulley and down the other side.

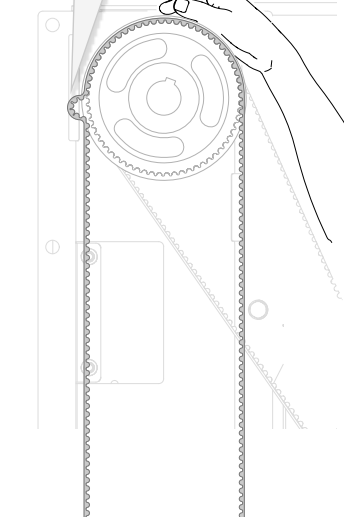



Keep lower hand a safe distance from pulley
12"

4

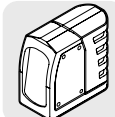

Laser level

Level the door panel again.

If the door panel is not level, repeat these steps and retest.

If the door panel is level, reset the tension on the belt.

5

To reset the tension on the belt:

- 1: Tighten** the top front nut to increase the tension.
- 2: Press** the front and rear legs of the belt together to test tension.
- 3: Adjust** the height of the top nut as needed to reach the correct tension.

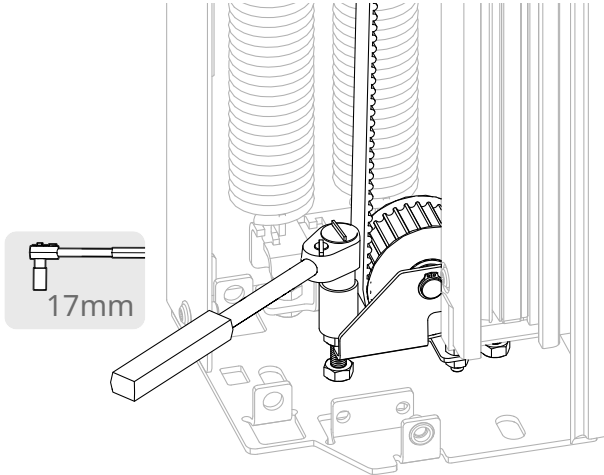
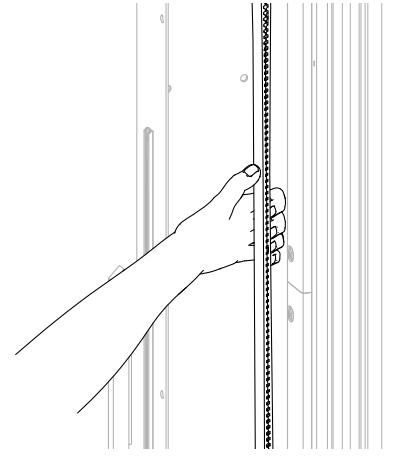
How to level the baseplate pulley assembly

- 1 **Loosen** the top nut of the bolt on the side opposite to the side the belt favors.
Lower the bolt until it touches the baseplate.
 Turn the bolt **one more half-turn** to raise that side of the pulley assembly, then test the door.

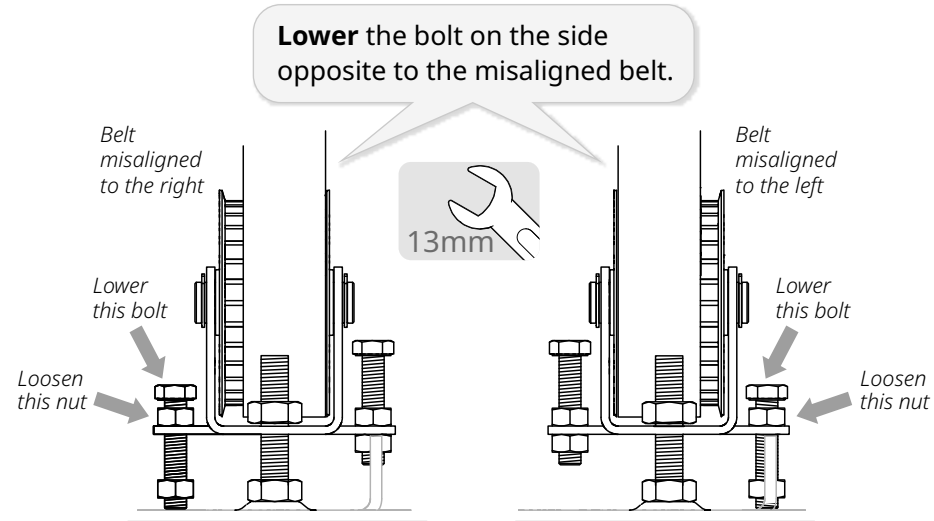

- 2 **Manually raise and lower** the door three (3) times.

- 3 **If the belt is not centered in the pulley assembly:** repeat these steps and retest.
If the belt is centered: raise the lower nut to lock the assembly in place.

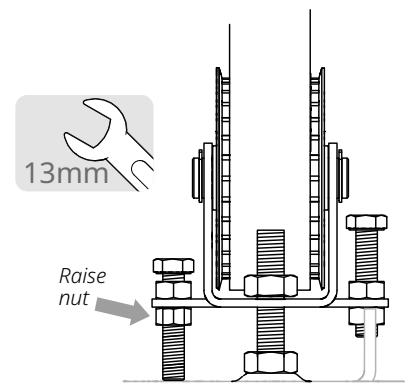

How to adjust the proximity sensor

What's the problem? The controller tracks the position of the manual break release through a magnetic sensor located in the motor. In some installation environments, the sensor needs to be adjusted from the factory preset to correctly track the brake release.

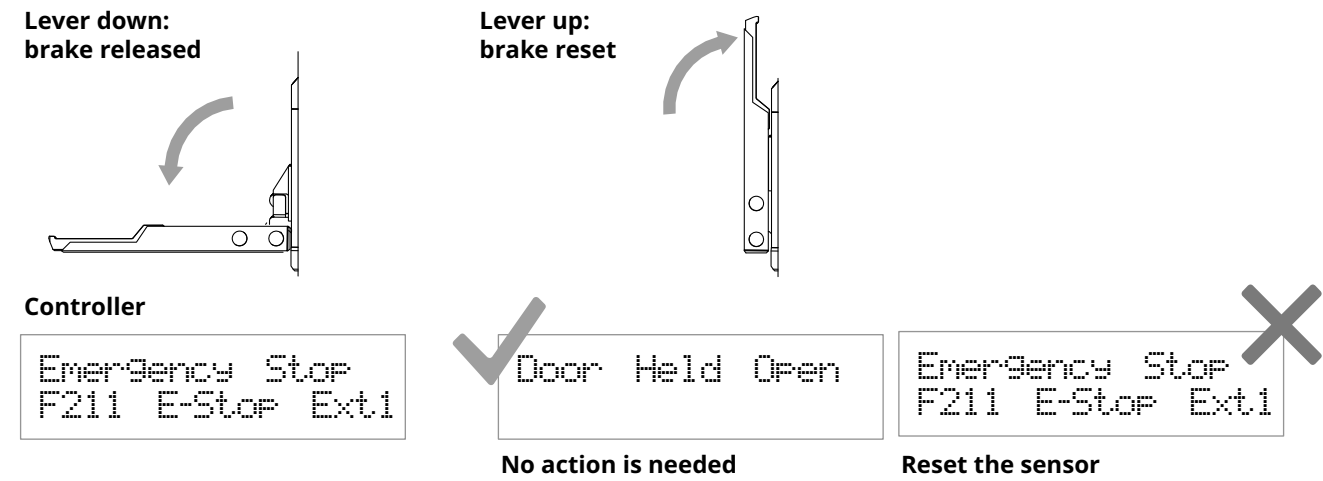

	⚠ WARNING	
	<p>Do not perform this procedure until the power disconnect is in the OFF position and a lockout/tagout is complete.</p> <p>Contact with high-voltage wires, or the door being activated unexpectedly, can cause death or serious injury.</p>	

- 1 At the motor, **remove** the brake release lever.
DO NOT remove the cable. The play in the spring allows it to turn with the release lever until it is free of the motor.

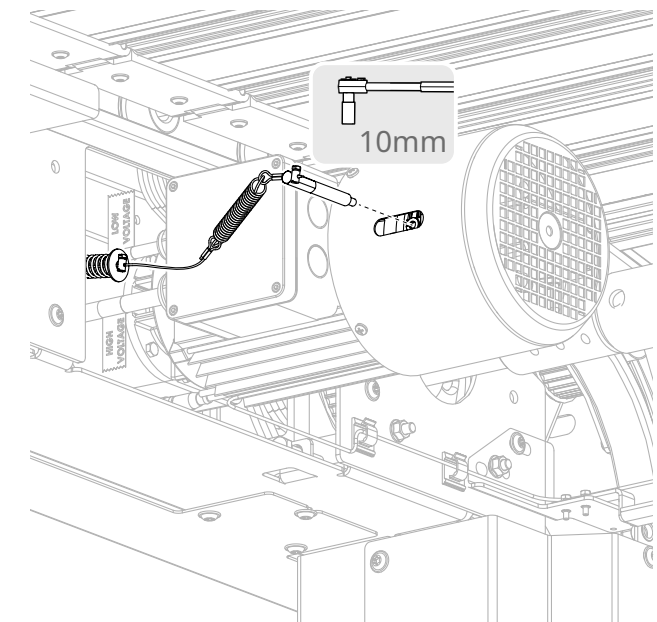

2 Remove the four screws and the bottom cover of the motor.

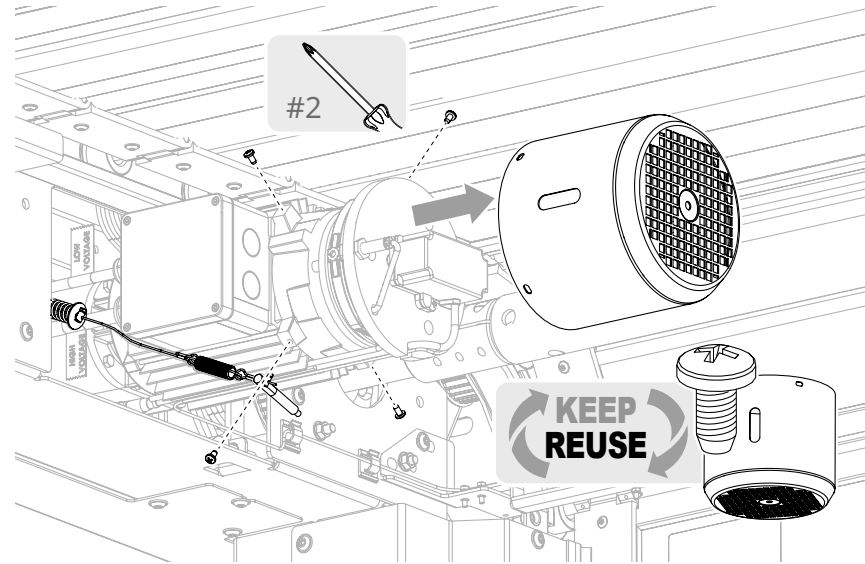

3 Check the distance between the sensor and the brake release arm ①. It should be .03"/.76mm, which is the **thickness of a credit card**. To adjust the sensor, first **loosen** the outer nut ②, then **tighten** the inner nut ③ to secure it in place.

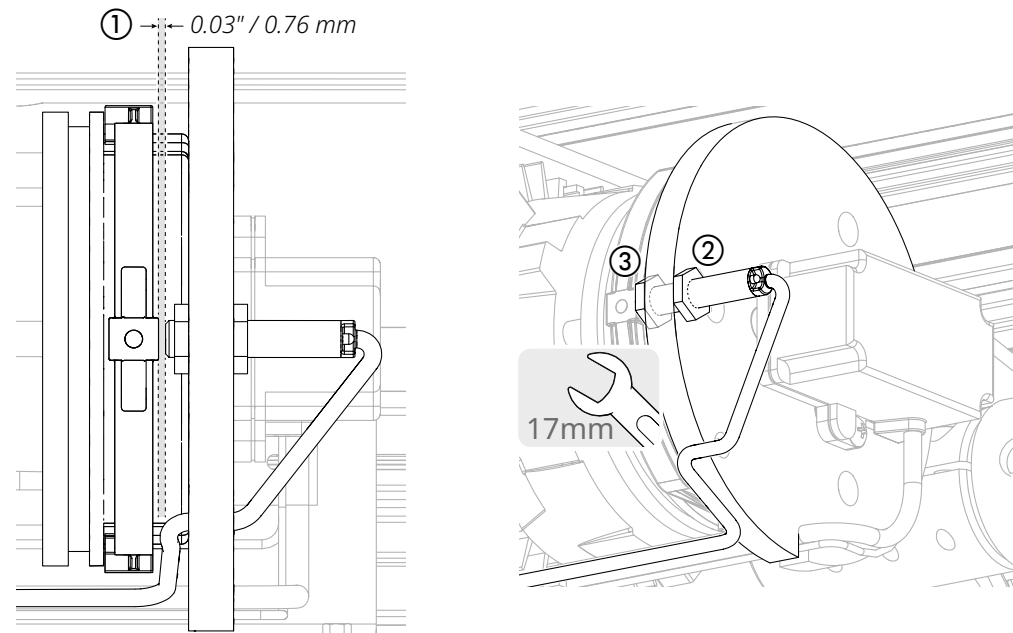

4 Test the manual brake release again. **If the controller displays the F211 error on reset**, repeat these steps and retest. **If the controller displays "Door Held Open"**, the issue is resolved. **Reinstall** the motor cover and the brake release lever.

How to manually reset the close limit (optional)

First: set the controller to Parameter mode and access Service level parameters

Do This	Result	Do This	Result
1 until the parameter screen displays		4 16X to set value to hexadecimal 10	
You are in Parameter mode. Go to parameter 999.		Set the value to 10 (Service level password).	
2 2X to reach parameter P:999		5 until question mark changes to checkmark (value saved)	
The Password parameter P:999 screen displays.		The Service level password is saved.	
3 1X to move cursor to the right (edit value)		6 1X to move cursor to left (parameters)	
You can now change the value of parameter P:999.		You can now go to parameter 275.	

Next: navigate to parameter P:275 (parameter P:221 for doors with photo eyes) and change the value

Do This	Result	Do This	Result
1 until parameter displays		3 until new value displays	
The default value is -12 (default at.		IMPORTANT Do not change the value by more than 10 increments. Then test the door.	
2 1X to move cursor to the right (edit value)		4 until question mark changes to checkmark (value saved)	
You can now change the value.		The new value is saved.	
<ul style="list-style-type: none"> ▪ The UP arrow increases the value and raises the close limit position for the door. ▪ The Down arrow decreases the value and lowers the close limit for the door. ▪ Each press of an arrow changes the limit by a fraction of an inch, which gives you precise control of the value. 		5 until door returns to run mode	

How to finish testing the door and the safety features

Navigate to parameter P:980 and set the value to 4 so the door will cycle continuously

Do This	Result
<p>1 until parameter displays</p> <p>The default value is 0.</p>	<p>P: Operat. Mode 5 980= 0 #</p>
<p>2 1X to move cursor to the right (edit value)</p> <p>You can now change the value.</p>	<p>P: Operat. Mode 5 980= 0v#</p>
<p>3 4X to change the value to 4</p>	<p>P: Operat. Mode 5 980= 4?#</p>
<p>4 until question mark changes to checkmark (value saved)</p> <p>The new value is saved.</p>	<p>P: Operat. Mode 5 980= 4v#</p>
<p>5 until door returns to run mode</p>	<p>Spiral [xxx] Cycles</p>
<p>6 press either arrow to start cycling</p>	<p>Act 1 5 Sec</p>

1 Watch the door as it cycles.

- **Make sure** the door panel rises to the fully open position, remains in place for the standard time, then closes to the fully closed position.
- **Make sure** the fully open and fully closed positions remain at the set limits.
- **Make sure** the reversing edge is level when the door is fully closed.

IMPORTANT ▪ **Let the ACL timer** hold the door open through each cycle. Shortening the timer while the door is cycling can cause the motor to overheat.

2 While the door cycles, **look and listen** for:

- **Unusual noises** such as grinding, whining or excessive motor noise
- **Excess movement** by the motor, drive or drum.
- **Unexpected delay** in activation or unusually long time period before automatically closing.

3 Make sure the Pathwatch LED strips operate correctly as the door opens and closes:

- **Continuous red light** while the door closes.
- **Three-second sequence** of yellow light before the door closes.
- **If the door also has a Pathwatch II** warning light at the top of the door:
 - There is also a continuous red light **while the door opens.**
 - The three-second sequence before the door closes is **red instead of yellow.**

4 Make sure the blue ① and green ② LEDs are activated in both light curtains, and that the red LED in the receiver ③ is **NOT** activated.

Receiver Laser level Transmitter

① ② ③

If the red LED is on, run a laser level on the vertical guide track to make sure light curtains are at the same height. **Adjust** if necessary.

If the red light does not go off, or if you see a different combination of lights, call Rytec technical support at 800-628-1909 and request **Service Bulletin #274.**

5 Test the light curtain by placing your hand flat across the light curtain in the path of the door at the top ①, middle ② and bottom ③ of the light curtain while the door panel closes.

① ② ③

Make sure the door panel returns to the fully open position each time the light curtain is activated.

Make sure the door panel stops immediately when you place your hand at the top ① of the light curtain, and gradually when you place your hand in the middle ② or at the bottom ③.

⚠ WARNING

Make sure you are standing clear of the door panel while performing this test.

6 Test the reversing edge by placing your arm in the path of the door while it is closing.

IMPORTANT **Make sure** you place your arm above the light curtains.

The door panel should stop, then reverse direction and rise to the fully open position.

7 IMPORTANT

Set the controller to parameter mode.

Set Parameter 980 back to 0 to take the door out of continuous cycle.

Return to run mode.

8 Activate the door using each activating system at least three times per system.

How to complete the installation



It is recommended that you **do not use power tools** for these steps. Overtorquing screws can damage the riveted nuts that secure them..

1 Reinstall both side column covers.

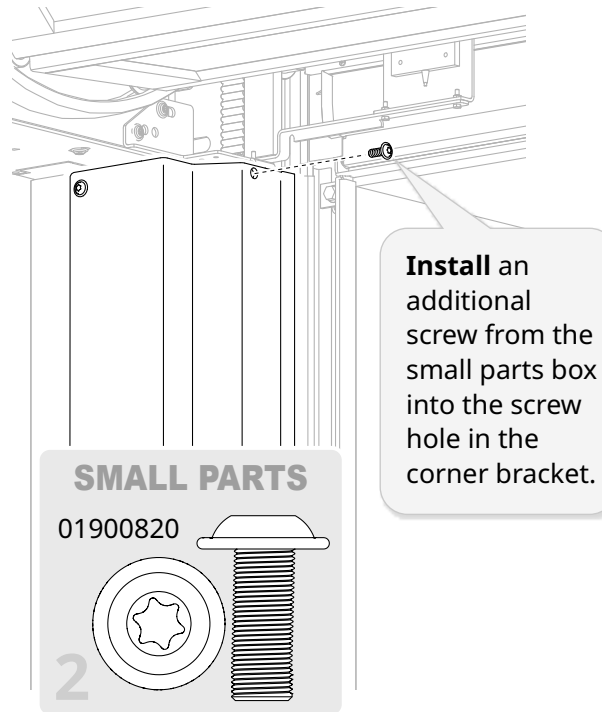
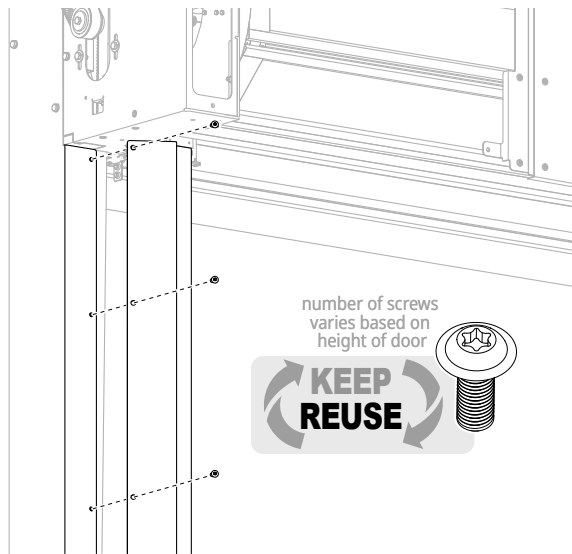

2 Reinstall both console covers.

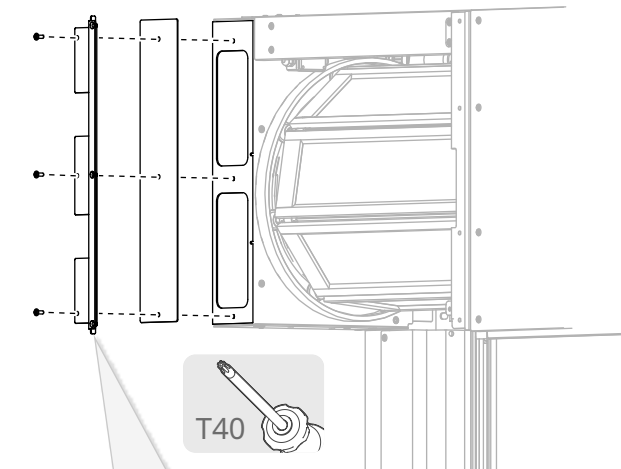
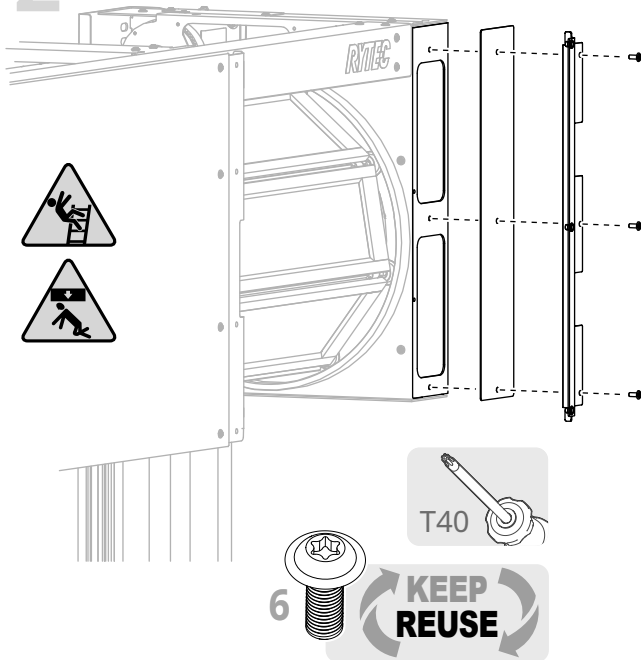

3

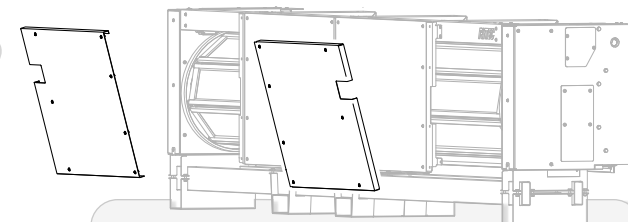

If the door has a preinstalled front hood cover, **reinstall** the front panels. **Locate** the display covers and hardware in the small parts box and **install**.

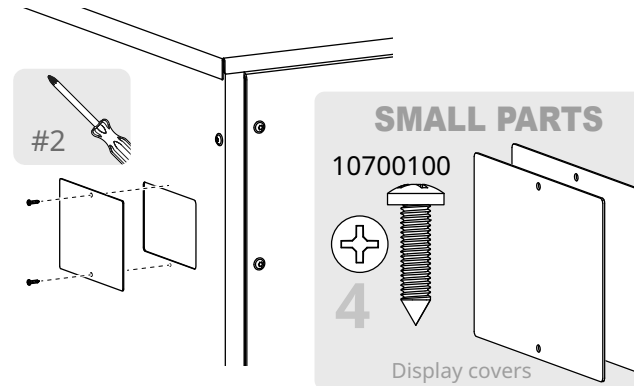

T40

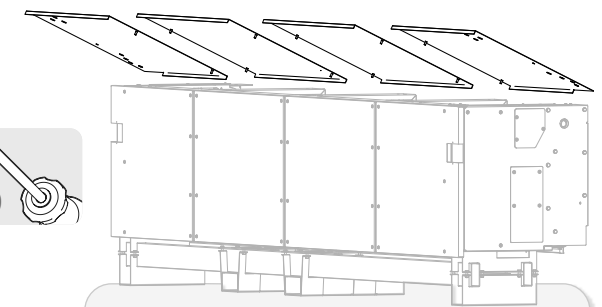

If the door has a preinstalled flat top hood cover, **reinstall** the top panels.

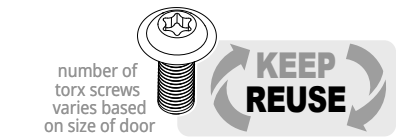

Notes:
Number of panels varies based on size of door.
-S and -S/R doors have both top and bottom front spreaders.

4 Reinstall the belt guard cover.

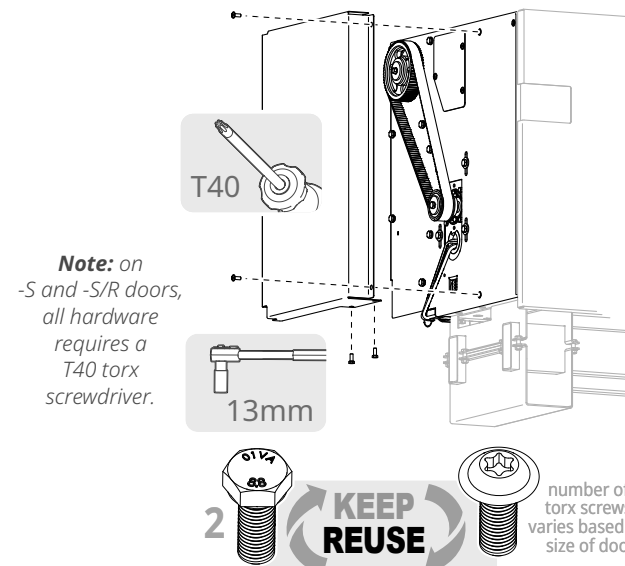

6 Caulk

between the door opening and the door.

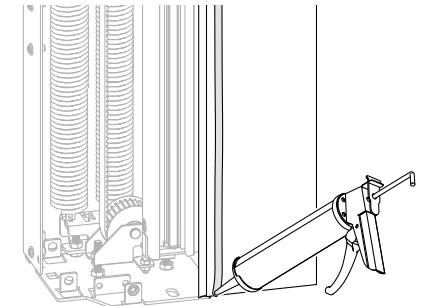

7 Full vision doors: remove the protective plastic film from both sides of each door slat.

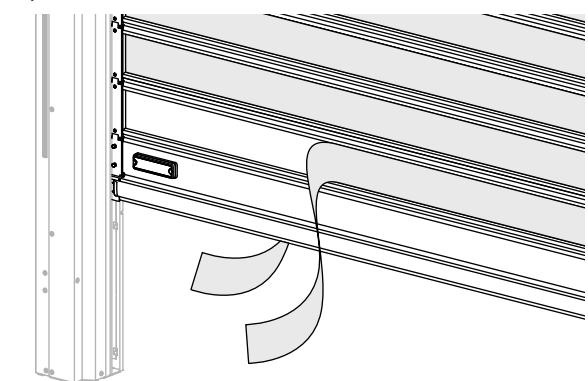

CAUTION

Film can release a static charge when removed.

5 If necessary, use the spray paint to correct blemishes in the door finish.

