

R

Y

T

E

C

Sure-Seal™

Installation Manual



P.O. Box 403, One Cedar Parkway, Jackson, WI 53037

Phone: 262-677-9046 Fax: 262-677-2058

Rytec Website: www.rytecdoors.com, Rytec On-line store: www.rytecparts.com

Rytec E mail: helpdesk@rytecdoors.com, Parts E mail: Parts@rytecdoors.com

[Revision: A (11-26-2019), R1170928-0, ©Rytec Corporation 2010]

TABLE OF CONTENTS

PAGE

INTRODUCTION	1
HOW TO USE MANUAL	1
DOOR SERIAL NUMBER(S).....	1
INSTALLATION.....	2
MATERIAL, TOOLS, AND EQUIPMENT	2
ADDITIONAL REQUIREMENTS	2
Labor and Site Requirements.....	2
Forklift Requirements	2
Electrician’s Responsibilities.....	2
Fill-In Material Requirements.....	2
GENERAL ARRANGEMENT OF DOOR COMPONENTS	3
UNCRATING	3
ANCHORING METHODS	3
Concrete, Block, or Brick Walls.....	3
Wood, Block, Brick, or Insulated Walls	4
Insulated Wall	4
LOCATING CENTERLINE OF DOOR OPENING	4
LOCATING SIDE COLUMNS	4
SIDE COLUMNS	5
HEAD ASSEMBLY	7
ANCHOR PLATES	9
JUNCTION BOX.....	9
ANTENNA	9
ENCODER.....	10
DOOR SEALING	11
CONTROL PANEL AND ELECTRICAL CONNECTIONS	11
DOOR OPEN & CLOSE LIMIT POSITIONS	12
Close-Limit Position.....	12
Open-Limit Position	12
(OPTIONAL) REVERSING EDGE SWITCH INSPECTION AND ADJUSTMENT ..	12
Reversing Edge Switch Air Bleed Check	12
Reversing Edge Switch Sensitivity Adjustment.....	13
RESETTING BOTTOM BAR	13
PATHWATCH LED™ WARNING LIGHTS	14
Front.....	15
Rear.....	15

TABLE OF CONTENTS

	PAGE
PHOTO EYES	16
Front.....	16
Rear.....	16
Testing Photo Eyes	17
AIR BLOWER (DOOR OPENING HT ≤ 16 FT)	17
SIDE COLUMN HEATED BLOWER	18
CLEAR SIDE COLUMN TOP COVERS	20
FINAL CHECKS	20

INTRODUCTION

The information contained in this manual will allow you to install your Rytec Sure-Seal™ door in a manner that will ensure maximum life and trouble-free operation.

Any unauthorized changes in procedure, or failure to follow the steps as outlined in this manual, will automatically void the warranty. Any changes in the working parts, assemblies, or specifications as written that are not authorized by Rytec Corporation, will also cancel the warranty. The responsibility for the successful operation and performance of this door lies with the owner of the door.

DO NOT OPERATE OR PERFORM MAINTENANCE ON THIS DOOR UNTIL YOU READ AND UNDERSTAND THE INSTRUCTIONS CONTAINED IN THIS MANUAL.

If you have any questions, contact your Rytec representative or call the Rytec Technical Support Department at 800-628-1909. *Always refer to the serial number of the door when calling the representative or Technical Support.* The serial number is located in several locations, see DOOR SERIAL NUMBER section.

A wiring schematic is provided with each individual door, specifically covering the control and electrical components of that door.

HOW TO USE MANUAL

Throughout this manual, the following key words are used to alert the reader to potentially hazardous situations, or situations where additional information to successfully perform the procedure is presented:

! WARNING

WARNING is used to indicate the potential for personal injury, if the procedure is not performed as described.

! CAUTION

CAUTION is used to indicate the potential for damage to the product or property damage, if the procedure is not followed as described.

IMPORTANT: *IMPORTANT* is used to relay information **CRITICAL** to the successful completion of the procedure.

NOTE: *NOTE* is used to provide additional information to aid in the performance of the procedure or operation of the door, but not necessarily safety related.

DOOR SERIAL NUMBER(S)

To obtain your **DOOR SERIAL NUMBER**, there are five universal locations where this information can be found. These are on the outside bottom & inside the door of the System 4 control panel, the left and right side columns at approximately eye level, and the drive motor/head assembly. (See Figure 1)

IMPORTANT: *When installing multiple doors of the same model, verify & match the serial numbers of all the components for each door (i.e. control panel, side columns, head assembly, etc.).*

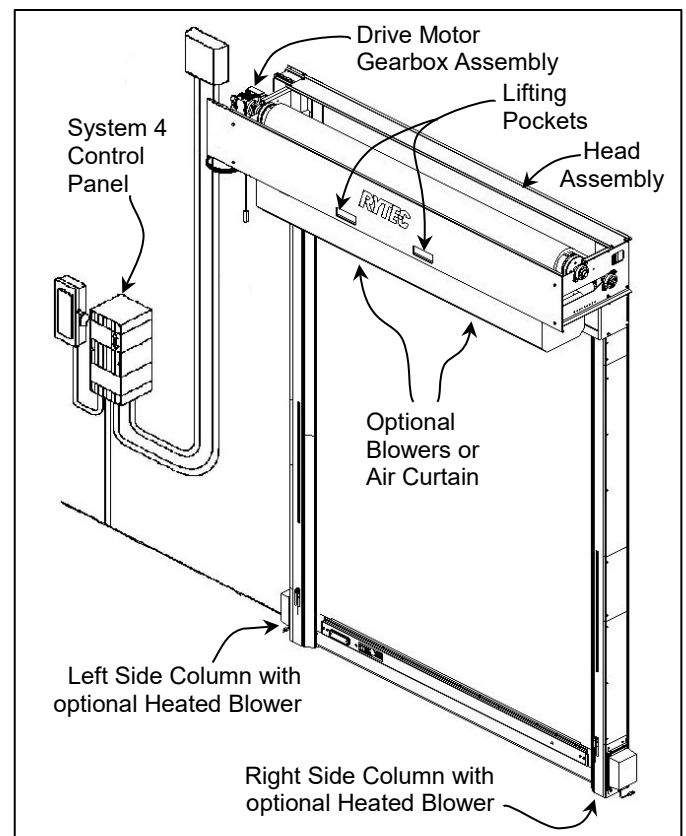

Figure 1

NOTE: *The lifting pockets in the head assembly are there for forklift handling only.*

INSTALLATION-MATERIAL, TOOLS, AND EQUIPMENT

INSTALLATION

MATERIAL, TOOLS, AND EQUIPMENT

1. Threaded rod ($\frac{1}{2}$ -in. diameter) and other various wall anchor hardware and material. Concrete Anchor bolts ($\frac{1}{2}$ -in. diameter). (See "ANCHORING METHODS" on page 3)
2. Assorted shim stock. (See Figure 10)
3. Double-sided tape (to temporarily hold shims).
4. Carpenter's or spirit level (4-ft. minimum length).
5. Carpenter's square.
6. Fish tape.
7. Hammer drill.
8. Masonry drill bit (for $\frac{1}{2}$ -in. diameter anchors).
9. Three or four bar clamps (48-in. long).
10. Four 12" C-clamps.
11. Pencil or Marker.
12. Hammer or mallet and blocks of wood.
13. Crowbar or pry bar.
14. Assorted hand tools (pliers, tape measure, etc.).
15. Socket and wrench sets.
16. Water level, line level, or transit.
17. Two ladders (taller than height of door opening).
18. Forklift (see "Forklift Requirements").

ADDITIONAL REQUIREMENTS

Labor and Site Requirements

1. Two installers.
2. An electrician is required for making all electrical connections. (See "Electrician's Responsibilities")

NOTE: All electrical work must be performed in accordance with local, state, and all applicable building codes.

3. 100% accessibility to the door opening during the entire installation process. No traffic should be allowed to pass through the opening while the door is being installed.

Forklift Requirements

A forklift supplied by the customer, dealer, or installer is mandatory for the safe and proper installation of this door. The forklift should have:

- 4,000-pound lift capacity.
- minimum height ability — door height plus 18 in.
- side-shift capability (desired).

Electrician's Responsibilities

For complete details on the responsibilities of the electrician, refer to the Rytec System 4 Drive & Control Installation, Owner's Manual, & Door Specific Electrical Schematic.

1. Install fused disconnect and Rytec control panel. (See Figure 2 for typical installation)

2. Install all necessary conduit tubing.

NOTE: Separate conduit must be run for high and low voltage wiring.

3. Run electrical power lines to disconnect.
4. Run power lines from disconnect to control panel.
5. Run power lines from control panel to junction box(s) and door.
6. Run power lines from control panel to door motor.
7. Run low-voltage cables from control panel to door.
8. Wire low-voltage safety devices and activators (if used).

Run high and low voltage wires/cables in separate metal conduit to the bottom of the System 4 control panel.

All wires/cables must be cut to length. **DO NOT** leave excess wire/cable loops on the door or in the control panel. Excess wires/cables can cause problems.

Fill-In Material Requirements

Some applications may require the use of a door pullout (extension) to gain clearance of an existing obstruction between the door and the door opening. The following materials can be used to fill the space or gap between the door and the door opening.

1. 16-gauge hot-rolled sheet steel.
2. 2-in. x 2-in. x $\frac{3}{16}$ -in. angle iron.
3. Insulated panels.

NOTE: If any pullout or build out is used in the installation it must be insulated to prevent frost and ice buildup on or in the door. Failure to properly insulate the pullout can affect the operation of the Sure-Seal door.

It is very important to seal and caulk around the pullouts to prevent frost and ice buildup.

INSTALLATION-GENERAL ARRANGEMENT OF DOOR COMPONENTS

GENERAL ARRANGEMENT OF DOOR COMPONENTS

Figure 2 shows the location of the major components of the door and the general placement of the associated subassemblies for a typical installation.

This illustration is provided to you for informational purposes only. It should not be relied upon solely during the installation of your door and its sub-assemblies.

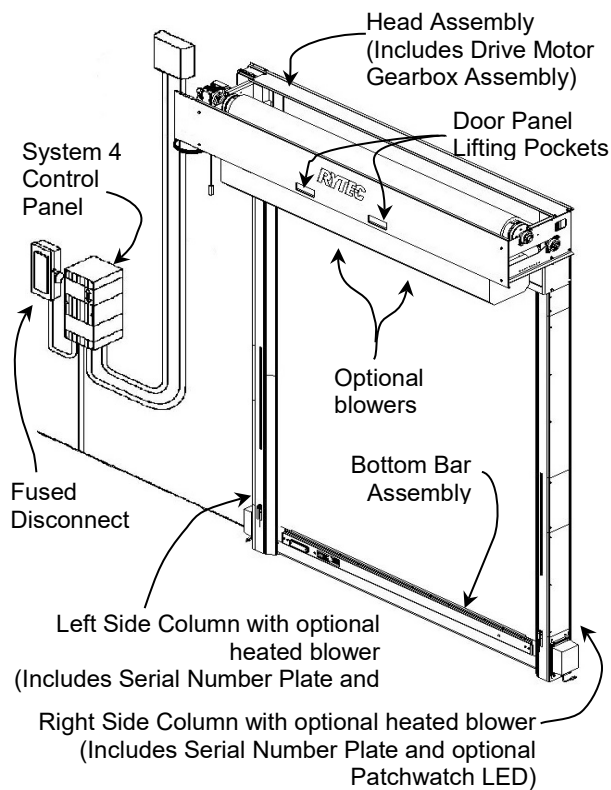

Figure 2

NOTE: Figure 2 shows the front side of the door. Left and right are determined when viewing the front side of the door.

UNCRATING

Your Rytec door has been crated to allow for minimal handling of assemblies during the installation process.

NOTE: Remove parts and sub-assemblies from the shipping crate in the order directed throughout this manual.

1. Remove the top of the crate.
2. Remove the front of the crate. (See Figure 3)

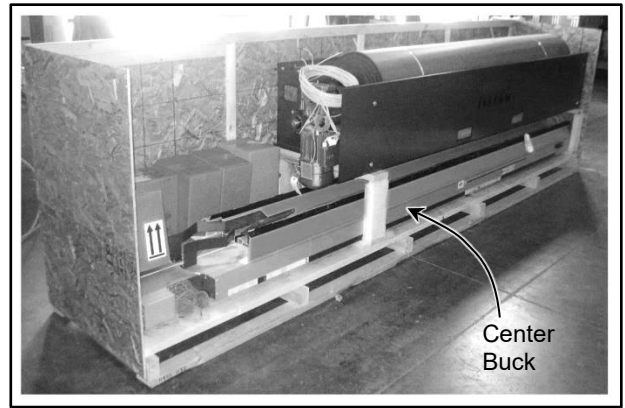

Figure 3

ANCHORING METHODS

Correct anchoring of the side columns to the wall and the floor is important for the smooth and safe operation of the door. The wall material should be strong enough to support the weight of the door and all wall anchors.

Figure 4 through Figure 7 show anchoring methods for various types of walls. Use the method that is best suited for your particular installation site.

All necessary anchoring hardware and material required for the installation of this door are the responsibility of the door owner. If you have any questions, call your Rytec representative or the Rytec Technical Support Department at 800-628-1909.

NOTE: Use $\frac{1}{2}$ -in. diameter threaded through bolts or $\frac{1}{2}$ -in. diameter threaded rods to anchor the door to all wall applications. Use $\frac{1}{2}$ -in. diameter concrete anchor bolts to anchor the door to a concrete floor.

If expansion anchors are used, a quarterly inspection should be implemented for safe and secure door operation.

Concrete, Block, or Brick Walls

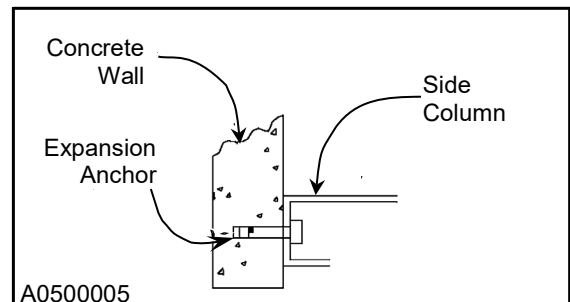

Figure 4

INSTALLATION-LOCATING CENTERLINE OF DOOR OPENING

Wood, Block, Brick, or Insulated Walls

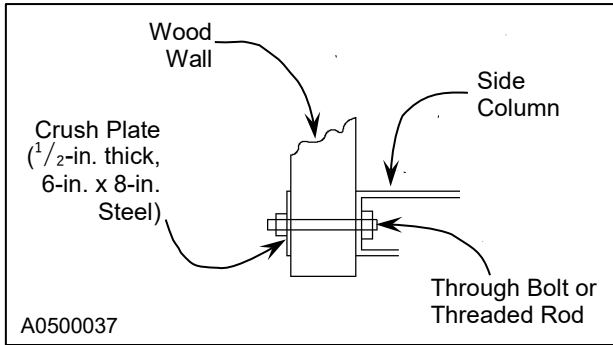

Figure 5

Insulated Wall

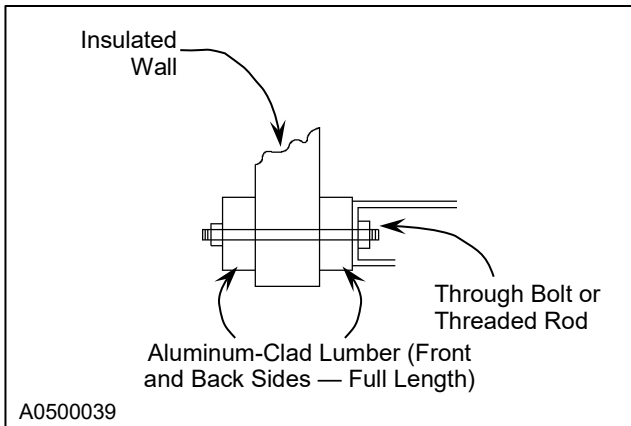

Figure 6

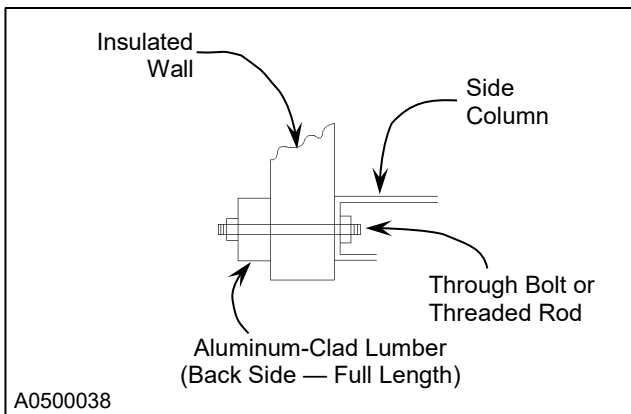

Figure 7

LOCATING CENTERLINE OF DOOR OPENING

NOTE: Accurate measurements are critical for the proper installation and operation of your Rytec door. Verify all measurements.

1. Measure the width of the door opening.
2. Divide the measurement in half to locate the centerline. Then mark the centerline along the floor. (See Figure 8)

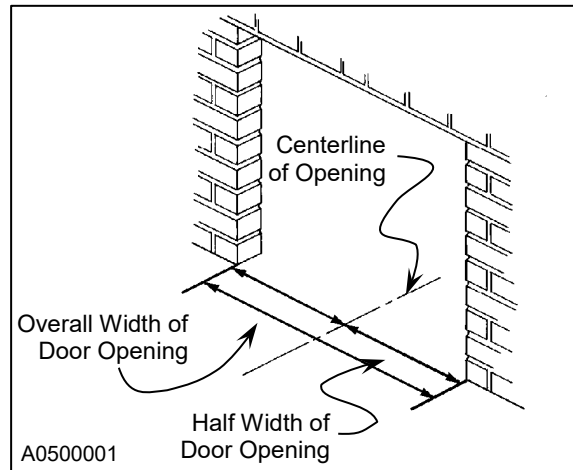

Figure 8

LOCATING SIDE COLUMNS

1. Locate the layout drawing of the door. It should be attached to the small parts carton packed inside the shipping crate. This drawing identifies the production width of your door. Verify the dimension provided by measuring the width (length) of the head assembly.
2. Using the centerline as a reference point, lay out and mark half of the door's production width along the floor. (See Figure 9)



This door is equipped with a breakaway bottom bar assembly. To ensure that it works properly, the width of the door opening must not be smaller (narrower) than the production width of the door. If the width of the opening is narrower than the width of the door, do not proceed with the installation. Contact your Rytec representative or the Rytec Technical Support Department at 800-628-1909.

INSTALLATION-SIDE COLUMNS

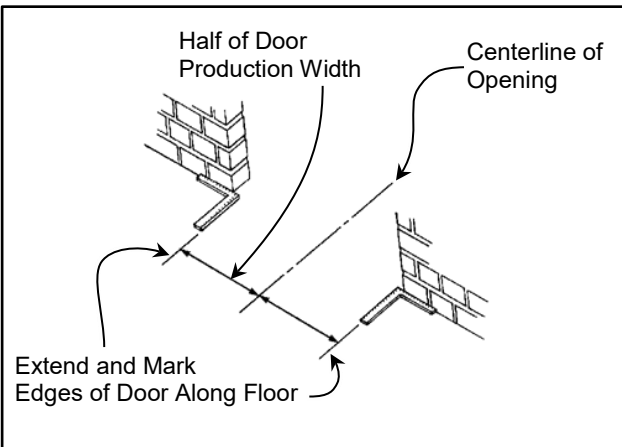

Figure 9

3. With a carpenter's square placed against the wall, mark both sides of the door along the floor. Extend the line along each edge.
4. Check the floor for level across the door opening. The floor must be level within 0.12 in. from side – to – side. If one side of the opening is higher than the other, a shim under the low side column will be required.

Figure 10 and Figure 11 show two methods that can be used to ensure level side columns.

NOTE: Contact the Rytec Technical Department if the floor is more than 1 in. out of level.

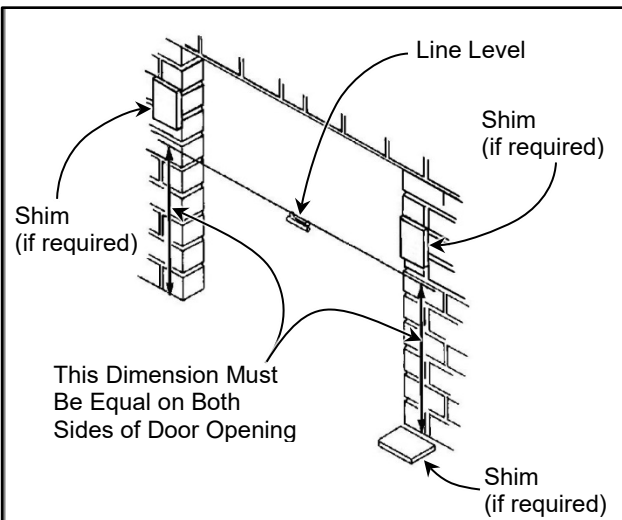

Figure 10

5. Use a plumb bob or carpenter's level to check the wall for plumb in the areas where the side columns are to be mounted. Also, inspect the wall for any obstructions.

If the wall is not plumb, shims must be used as required @ each side column fastener. If you find an obstruction, remove it or shim the column to avoid the obstruction. (See Figure 10 and Figure 11)

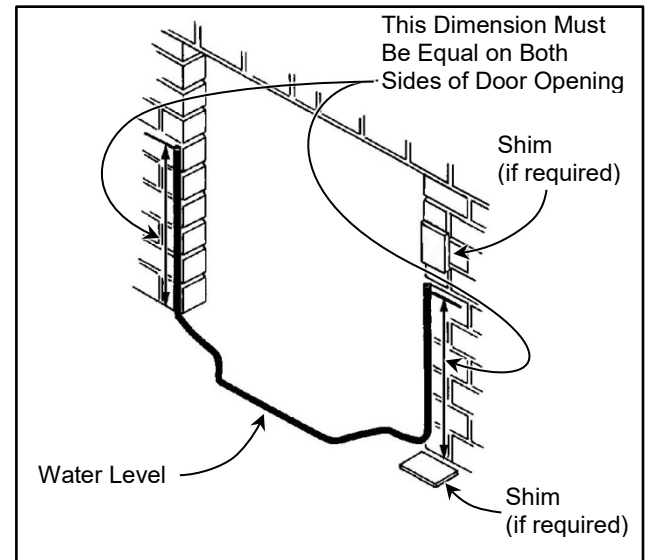

Figure 11

SIDE COLUMNS

The following procedure details the installation of the side columns.

CAUTION

Side columns are heavy; use proper lifting and support equipment when removing from crate. Personal injury may result from using improper handling procedures.

1. Remove the blocking from the head assembly buck in the middle of the shipping crate to gain access to the side columns. (See Figure 3)
2. Remove the side columns from the shipping crate. Remove the covers from the side columns by removing the screws that hold the covers in place. Save all hardware and covers for reassembly for each one. Do not mix the parts up.
3. Stand one side column on the floor. Place it against the wall on the appropriate side of the door opening (i.e. left on left side, right on the right side), just outside the line indicating the production width of the door. Use clamps as needed. (See Figure 12)

INSTALLATION-SIDE COLUMNS

IMPORTANT: It is critical that the side columns are mounted square and plumb with the wall and level across the door opening. Utilizing a 4-foot level and carpenter's square to check this will help ensure the columns are correctly set. Place shims as necessary.

Additionally, using bar clamps to temporarily secure the side columns to the wall will allow you make slight adjustments during the installation process.

WARNING

Before drilling any holes, ensure there are no electrical wires, water pipes, or gas lines, etc., buried in the floor or hidden in the wall.

- Once the side column is set plumb and square, mark the center of the slot locations and the column edges on the wall. Pre-drilled anchor points have been provided in the side column. Remove the side column and drill anchor holes in the wall. Reset the side column plumb and square. Anchor it to the wall. **DO NOT** fully tighten the anchors at this time - they will be tightened later in the installation after the head assembly is installed. (See Figures 12 - 14)

NOTE: Use $\frac{1}{2}$ -in. expansion shell or stud-type anchors for concrete walls. Use through bolts or threaded rods for brick walls and other applications where expansion anchors are not appropriate.

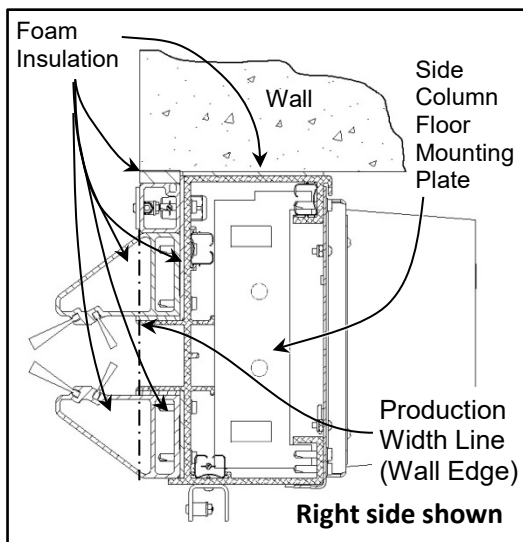

Figure 12

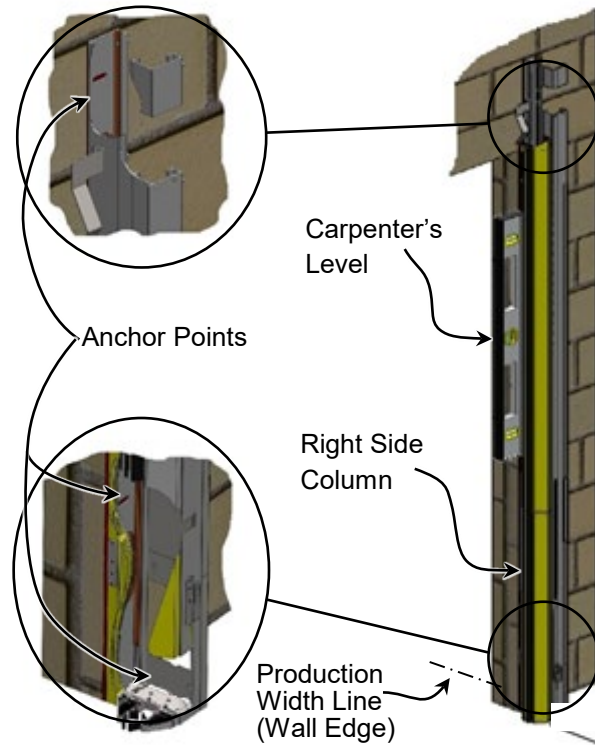

Figure 13

- Mount the opposite side column to the wall in the same manner used for installing the previous side column.
 - With both columns set and at least snugly bolted in place to the wall, once again check the overall plumb and squareness of each column. (See Figure 14)
 - Compare the diagonal measurements and the upper and lower horizontal measurements across the columns. The columns are square and parallel when the diagonal measurements are equal and the horizontal measurements are equal.
- Note:** It is critical that the horizontal distance between the mating surfaces of the side columns which the head bolts to, match the mating width between the head assembly mounting plates. (See Figure 14)
- If either column requires any slight repositioning (when the difference of either comparison is greater than $\frac{1}{4}$ in.), use a block of wood and a mallet to nudge the column(s) into the correct position.
 - Choose one of the side columns at this point and tighten all fasteners and set it in place. The opposite side column will likely need to be adjusted when installing the head assembly.

INSTALLATION-HEAD ASSEMBLY

NOTE: Personal injury or equipment damage may result from the head assembly not being secured when being lifted.

CAUTION

The head assembly is extremely heavy; use proper lifting and support equipment when removing it from the crate. Personal injury may result from using improper handling procedures.

Secure the head assembly to the forklift prior to lifting it to the top of the side columns.

NOTE: To prevent damage to the door components, use cloth or packing material between the forks and the head assembly. Pay close attention to the foam door panel.

2. Secure the head assembly with C-clamps and a strap around the front spreader, door panel drum, and the idler drum to the forks of the forklift or mechanical lift before lifting it into position. C-clamps should be used on both sides of the front spreader to secure the head in place. (See Figure 16 - 18)

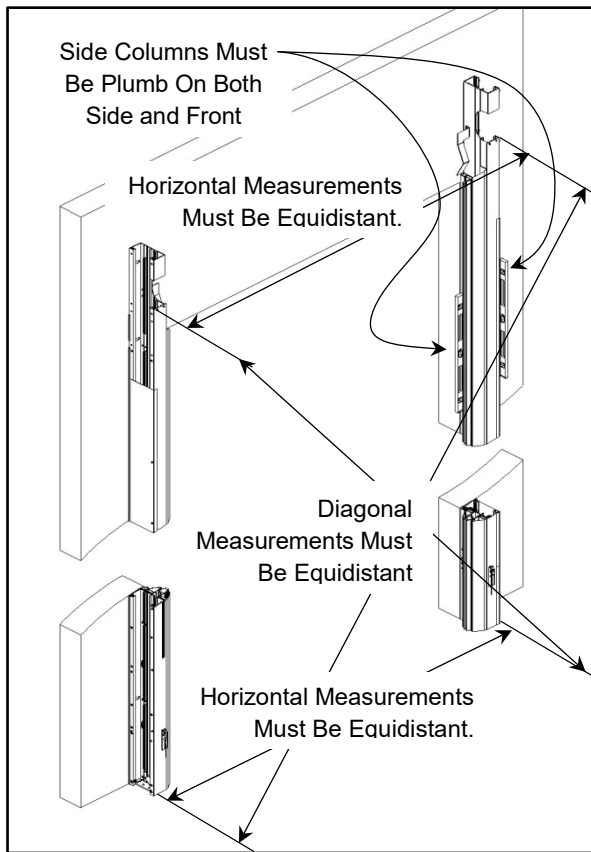

Figure 14

HEAD ASSEMBLY

1. Remove the head assembly from the crate. Using a fork lift, guide the forks into the slots in the front of the head assembly making sure that the forks are below the panel and idler drum. The lifting slots are provided to aid in lifting the head and preventing damage to the foam panel, drum, and head assembly. (See Figure 15 and Figure 16)

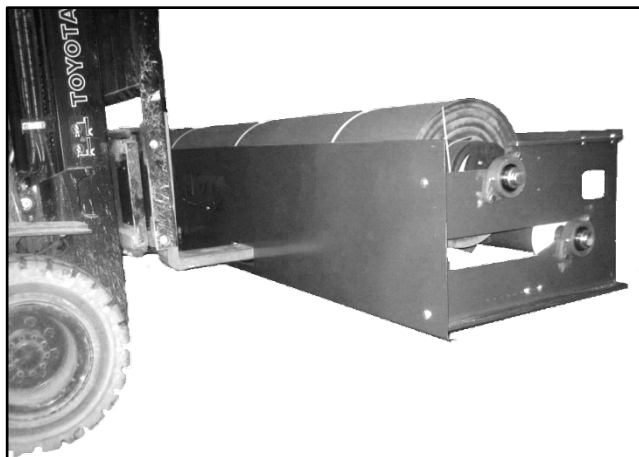

Figure 15

NOTE: Do not wrap the strap around the rear spreader when securing to lifting forks. This will damage it.

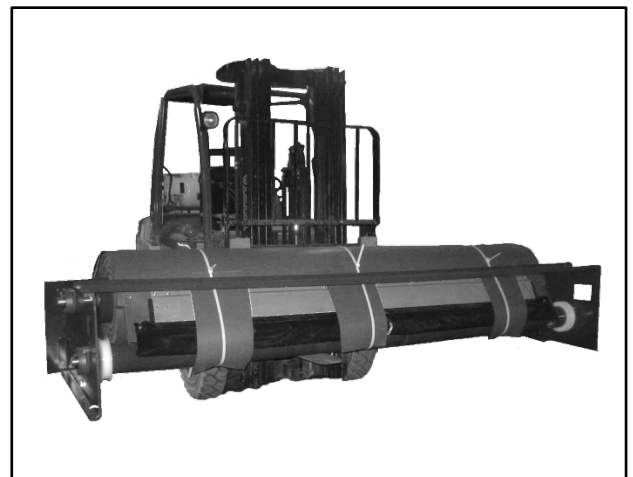

Figure 16

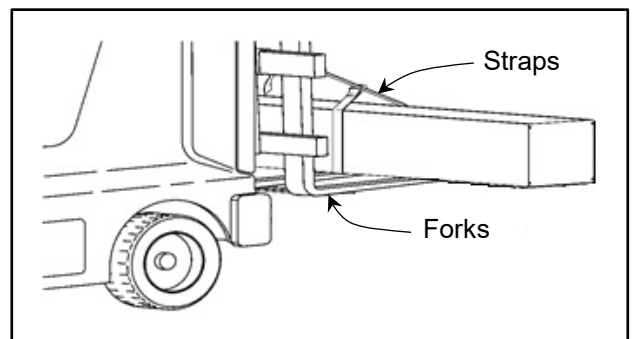

Figure 17

INSTALLATION-HEAD ASSEMBLY

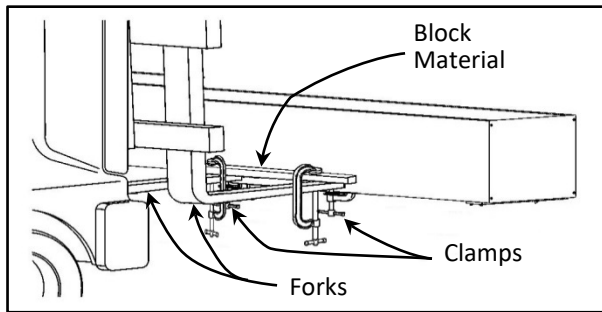

Figure 18

3. Check if there are optional Photo eyes or Pathwatch LED strips in the side columns. If there are, Insert the grommet with the Pathwatch LED and/or Photo eye wires running through it into the slot in the side column as shown.
4. With the head assembly safely secured to the forklift, raise it up above the door to mount to the side columns. Guide the head in toward the wall while keeping the side column edges clear of the head assembly mating edges and wires exiting the top of the side columns. Line up the mating holes on the head assembly with the fastener holes in the side columns. (See Figure 18 - Figure 20)

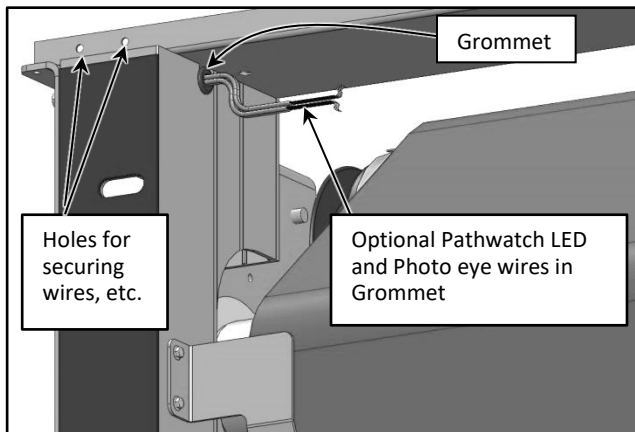

Figure 19

5. Fasten the head to the level and plumb side column that's locked in place with the specified fasteners. DO NOT completely tighten the fasteners. Adjustments will need to be made yet. The hardware is located in the small parts carton. (See Figure 20)
 - a. Install (4) $\frac{3}{8}$ -16UNC x $1\frac{1}{4}$ -in. hex flange machine screws and $\frac{3}{8}$ -16 Uni-Strut nuts on each side column/head mount (left and right side). (See Figure 20)
6. Next align and fasten the head assembly to the opposite side column just like in the previous steps. DO NOT completely tighten the fasteners. Adjustments will need to be made yet. (See Figure 20)

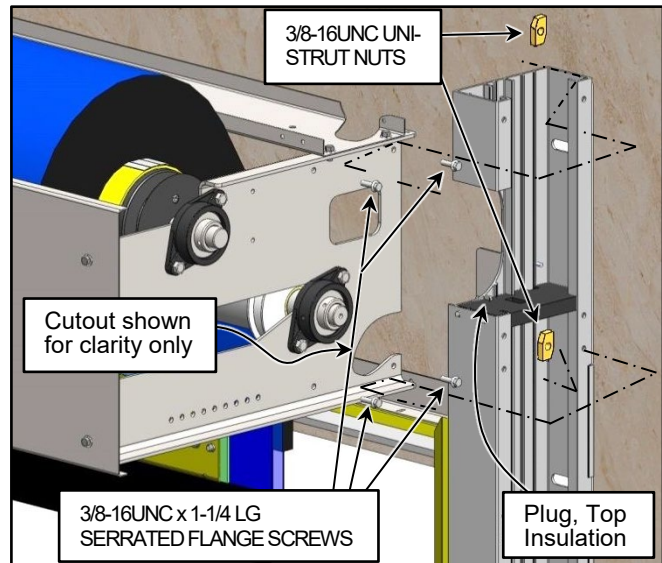

Figure 20 (Broken out view for clarity)

7. With the head assembly snugly bolted in place to the side columns, check the overall plumb and squareness of the overall assembly (side columns and head). Compare the diagonal measurements and the upper and lower horizontal measurements across the columns. The columns are square and parallel when the diagonal measurements are equal and the horizontal measurements are equal. Check the head for level and plumb.
8. Mount and secure the Top Rear Spreader Brush Seal in between the side columns as shown. Adjust to provide a proper door seal. Use alternating fastener holes. (See Figure 21)

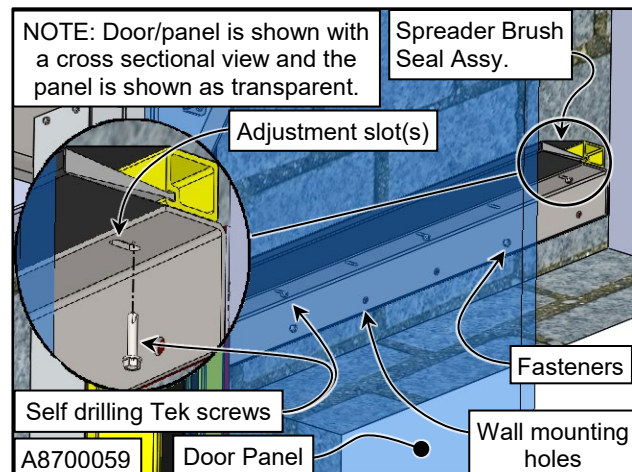

Figure 21

9. Once the assembly is set plumb, square, and, finish fully anchoring the loose side column to the wall.
10. Tighten the fasteners and secure the head assembly to the side columns.

11. Unclamp the head assembly from the forklift, remove the strap(s), and then remove the forklift. Be sure to carefully remove the forks from the head so no damage occurs.

NOTE: Anchor points in the head assembly are predrilled at the factory for the load bearing cross-sectional area. Do not add additional points for mounting. Please consult your Rytec representative or call the Rytec Technical Support Department at 800-628-1909 with questions.

12. Remove the bar clamps or other items that were used to secure the side columns to the wall.
13. Route the (optional) Pathwatch LED and Photo eye wires up between the rear spreader bar on the head assembly and the wall to the top of the spreader. Use zip ties or another similar fastener to secure them to the spreader in the holes provided. (See Figure 19)

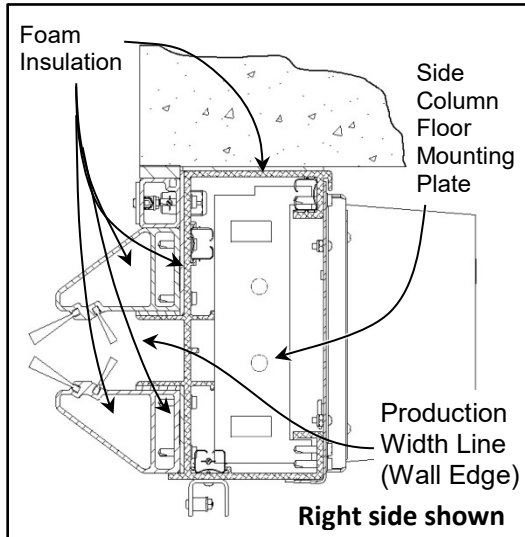

Figure 22

ANCHOR PLATES

1. Insert the side column floor mounting plates into the bottom of each side column. Make sure all wires, power cords, and any other items are not on or under the Anchor Plate. Damage could occur if they are. (See Figure 22)
2. Secure the position of the side columns on the floor. Using the holes of the side column mounting plates, locate and drill holes for the anchors, install them, and secure the plates to the floor.
3. Secure the side column mounting plates to the floor through the 2 holes in each plate. (See Figure 22)

NOTE: If a stud-type anchor is used for the bottom anchor, the anchor must not extend more than 1 in. above the base plate of the side column.

JUNCTION BOX

NOTE: A junction box may or may not be included based on the configuration of the door.

The junction box is shipped loose in the shipping crate and needs to be mounted separate of the door's head assembly.

1. Locate, identify, & remove junction box from the crate.
2. Orient the Junction Box assembly as shown. Mount the J-Box assembly with appropriate fasteners/anchors for the wall construction. Allow ample room for access to the J-Box, Bearings, Motor & the head assembly. (See Figure 23)

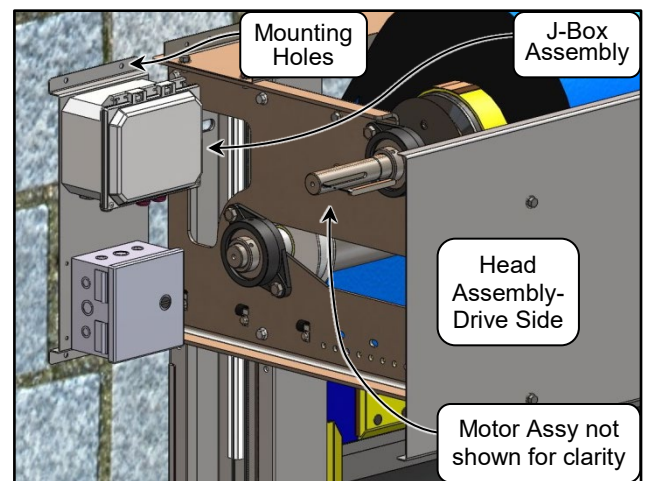

Figure 23

ANTENNA

NOTE: The antenna is an optional feature.

IMPORTANT: The antenna is a fragile and highly sensitive instrument. Extreme care should be used in handling this piece of equipment.

1. Remove antenna from small parts carton.
2. Carefully remove packing material from antenna. Inspect for damage.

NOTE: Do not install antenna if it is found to be damaged. Call your local Rytec representative or the Technical Support Department at 800-628-1909 for a replacement.

3. Locate and identify the insert nuts for mounting the antenna bracket assembly. They are on the lower inside of the front spreader on the drive side. (See Figure 24)

INSTALLATION-ENCODER

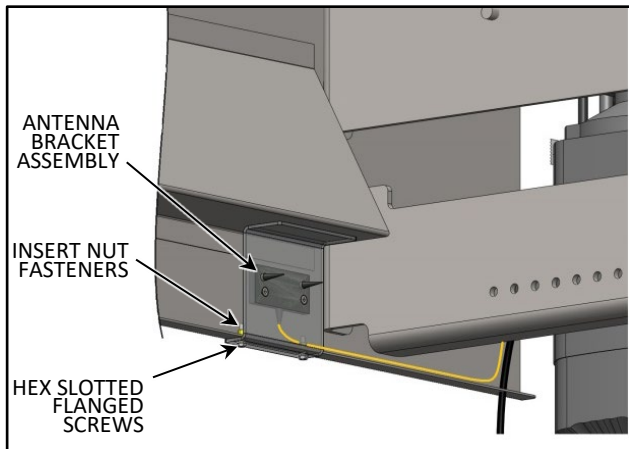

Figure 24

4. Install the antenna bracket assembly to the front spreader with (2) 10-24NC x $\frac{3}{4}$ " long hex flanged machine screws. Fastener hardware is located in the small parts carton. (See Figure 24)
5. Route the antenna wire along the front spreader to the motor encoder and connect it as documented in that section. (See Figure 24)

NOTE: To secure antenna cable, use plastic ties as required.

ENCODER

1. Install the Feig encoder hub shaft end to the end of the encoder coupling shaft and tighten set screw plate. The Feig encoder hub can be found in the small parts carton.

NOTE: The large flat washer, split lock washer, and encoder coupling shaft are factory installed on the gearbox. Use a mild thread locker on the set screw.

2. Install encoder mounting plate with encoder using two(2) M10-1.5 x 20 mm hex head cap screws.
3. Connect the encoder cable to the encoder.
4. Install plastic zip tie into the threaded hole in encoder mounting plate and secure the encoder cable. (See Figure 25)

All hardware is located in the small parts carton.

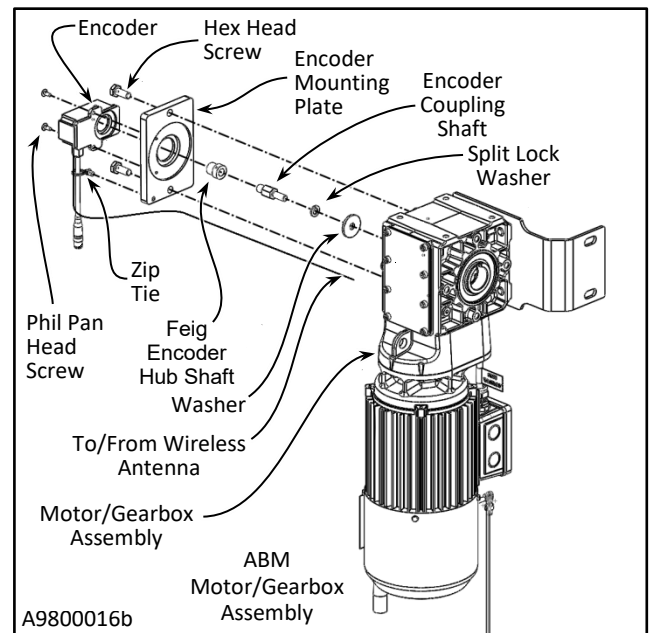

Figure 25

DOOR SEALING

Foam insulation is built into the side column. The insulation is a technical and important item in the proper operation of the Sure-Seal door. From the moment the door is uncrated until the door is installed, strict care should be taken not to damage the insulation on the back side of the side column. (See Figure 26)

In addition to the insulation, a thermal break foam core is constructed into the components of the door assembly. This gives the door an extra barrier to combat against temperature differential. (See Figure 26 & Figure 27)

For a tight and air-proof seal, a bead of caulk should be applied at the inside perimeter of the door assembly. Use a construction grade of caulk to seal the door.

IMPORTANT: Use caulk as directed per the manufacturer's instructions. Improper wall preparation may result in poor adhesion. The door may not be altered in any form to apply caulk.

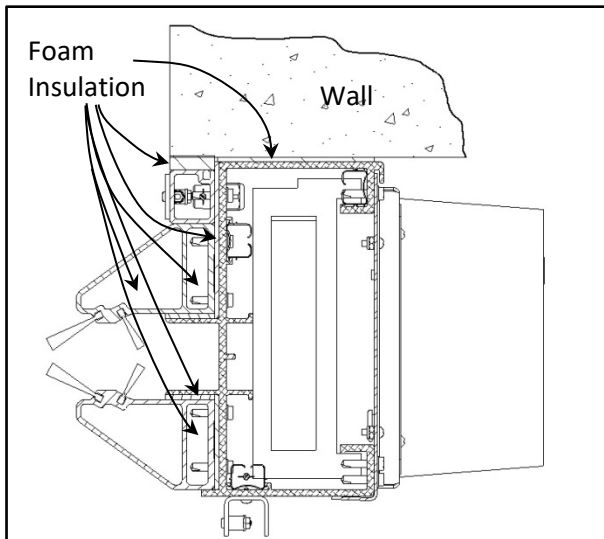

Figure 26

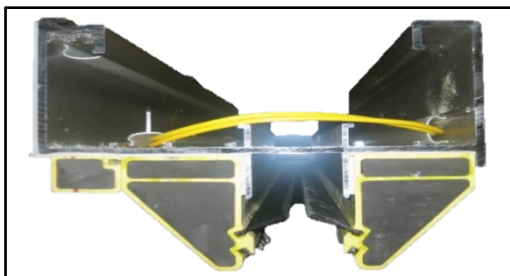

Figure 27

CONTROL PANEL AND ELECTRICAL CONNECTIONS

Once the door has been assembled, see the Rytec System 4 Drive & Control Installation, Door's Electrical Schematic, & Owner's Manual for information on control panel installation, electrical connections, door limit settings, and initial door start-up procedure.

Locate the electrical schematics in the red documents envelope in the small parts box and wire the door according to these specifications.

INSTALLATION-DOOR OPEN & CLOSE LIMIT POSITIONS

DOOR OPEN & CLOSE LIMIT POSITIONS

See the Rytec System 4 Drive & Control Installation & Owner's Manual for the proper procedure for setting the open and close door limits. The close- and open-limit door positions are detailed below.

Close-Limit Position

The close-limit position should be adjusted so that the door travel allows the edge seal on the bottom bar to gently seal against the floor. (See Figure 28)

CAUTION

Damage to the bottom bar parts can occur if the door seal is allowed to seal too tightly against the floor. If there is an optional reversing edge, it should NOT contact the floor.

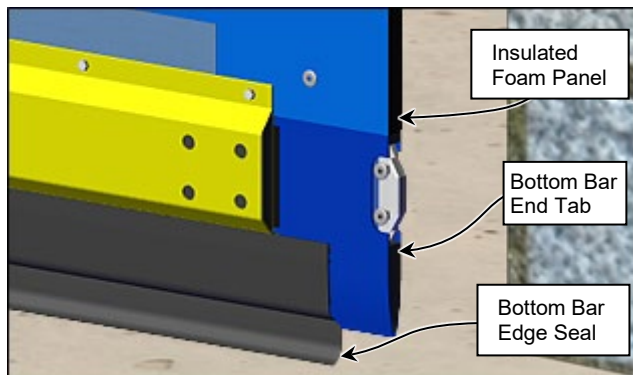

Figure 28

Open-Limit Position

When the door is knocked out of position, the System 4 Drive & Control takes over and will raise the tabs high enough to be reinserted into the side columns. The open-limit position should be adjusted so that the door travel allows a minimum of half the foam breakaway tab into the yellow channel guides of each side column. (See Figure 29)

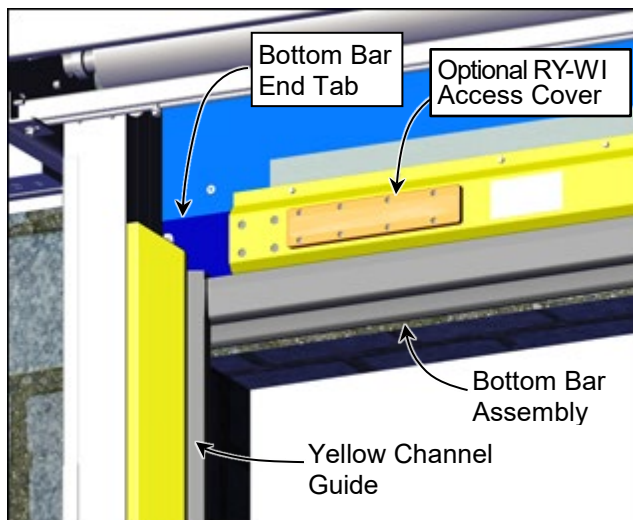

Figure 29

REVERSING EDGE SWITCH INSPECTION AND ADJUSTMENT

NOTE: The reversing edge is an optional feature.

WARNING

Do not stand under the door panel when testing the reversing edge. If the reversing edge switch is not working properly, the panel could strike personnel and cause injury.

To check the reversing edge switch, run the door through the down cycle. As the door is lowered, tap the bottom of the reversing edge. The door should immediately reverse direction and open. The door is set up from the factory for 3 impacts of the reversing edge after which it will remain open. If the reversing edge is tripped 3 times consecutively the door will remain open and code F:361 will appear on the display. Push and hold the STOP/ RESET button 3 to 5 seconds and the control will reset. Push the down arrow to close the door.

If the door does not reverse direction, check the air bleed and sensitivity of the reversing edge switch.

Reversing Edge Switch Air Bleed Check

The reversing edge switch is located inside the bottom bar assembly, on the same end as the drive motor.

WARNING

The disconnect must be in the OFF position and properly locked and tagged before performing the following procedure.

1. To inspect and adjust the switch, remove the access cover from the wireless enclosure assembly on the face of the bottom bar assembly. (See Figure 29)
2. Make sure the clear PVC hose is in tight contact with the air input post so that air leakage cannot occur and that vibration will not cause the hose to fall off. Also make sure the PVC hose is not kinked. (See Figure 30)

INSTALLATION-RESETTING BOTTOM BAR

- The air bleed has been set at the factory and should not require adjustment. If adjustment is necessary, turn the air bleed adjustment screws located on the front and back of the switch fully clockwise — but do not overtighten. Then turn each screw back (counterclockwise) one full turn.

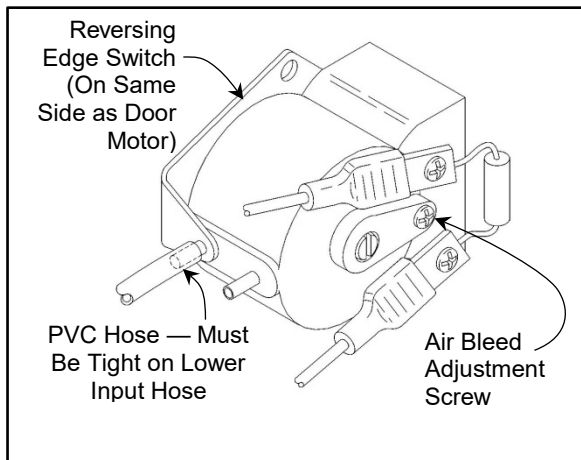

Figure 30

Reversing Edge Switch Sensitivity Adjustment



The disconnect must be in the OFF position and properly locked and tagged before performing the following procedure.

- The reversing edge switch is a normally open contact. The PVC hose is on the lower air input post. To adjust the switch, first remove the resistor from the contact terminals and attach an ohmmeter across the two terminals. (See Figure 31)

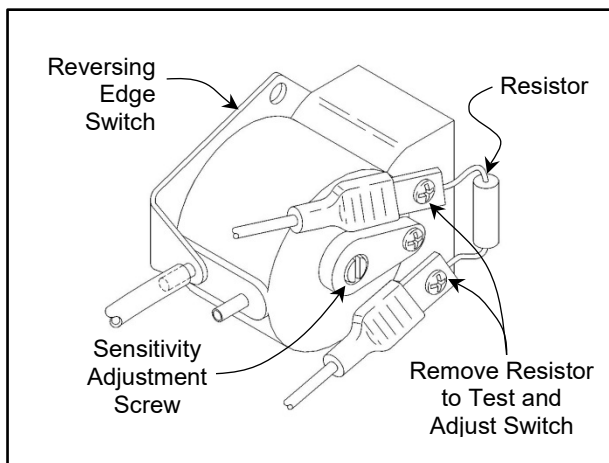

Figure 31

- Turn the sensitivity adjustment screw clockwise until continuity is achieved. Then turn the sensitivity screw 2 full turns counterclockwise for a standard setting. Some doors may require a further adjustment counterclockwise. (See Figure 31)

NOTE: Testing the reversing edge is the best way to determine sensitivity.

- Reattach the wires and resistor; then replace the access cover.

NOTE: If the reversing edge is too sensitive, the door may reverse direction during the closing cycle without coming in contact with an object. If this occurs, readjust the

RESETTING BOTTOM BAR

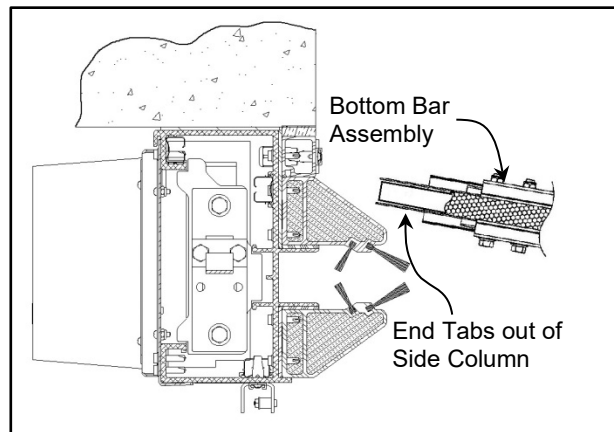

Figure 32

NOTE: The resetting bottom bar is an optional feature.

For doors with the optional fully automated self-resetting bottom bar, after a strike and a clear sensor path the door will automatically reset the bottom bar. The process goes as follows:

- The foam breakaway tabs have popped out of the side column's channel due to impact. (See Figure 32 and Figure 33)

NOTE: If the door panel was damaged during the impact, remove the door from service and repair. If you have any questions, contact your Rytec representative or call the Rytec Technical Support Department at 800-628-1909.

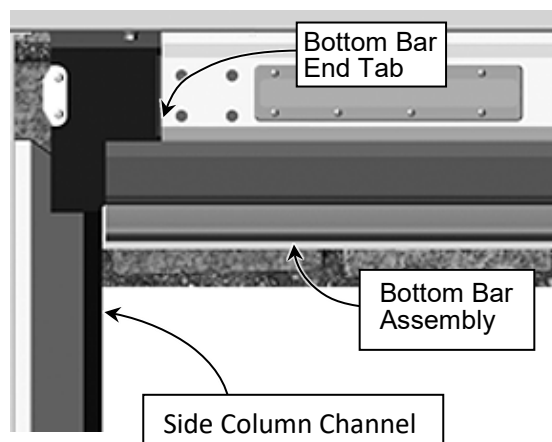

Figure 33

INSTALLATION-PATHWATCH LED™ WARNING LIGHTS

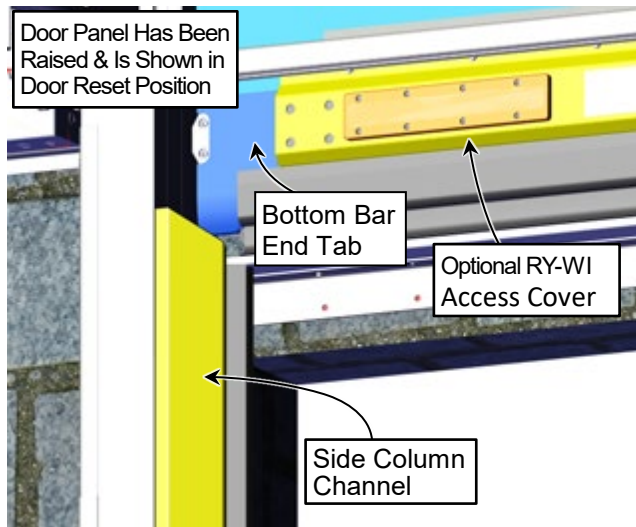

Figure 34

2. The door panel will momentarily pause and then execute the reset procedure.
3. The door panel's foam breakaway tabs will roll upward above the side column's channel. (See Figure 34)
4. The photo eye senses if the path is clear of any obstructions.
5. Then the door panel will guide itself into the channel and resume its normal operation. (See Figure 35)

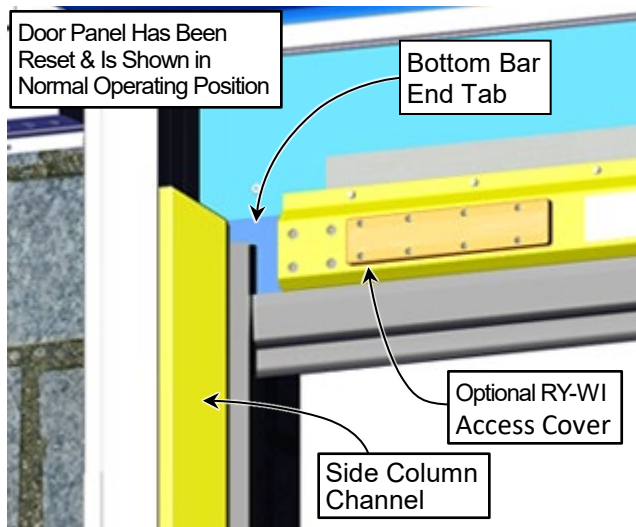

Figure 35

NOTE: The door function is fully automatic; it will reset, rise to the open position, and reinsert the bottom bar according to factory installed parameters. Cycling the door and checking for proper door operation is not required unless prescribed, but an occasional test of the self-repair system would ensure its proper operation. Should slight adjustments of the door be needed, please contact your Rytec Technical Support at 800-628-1909.

PATHWATCH LED™ WARNING LIGHTS

NOTE: The Pathwach LED™ is an optional feature.

The standard setting for the warning lights is 3 seconds prior to the door closing, the lights will flash yellow and then change to a steady red while closing. Adjustments to the closing time can be made through the System 4 Control Panel. Please contact your Rytec Technical Support department at 800-628-1909 for assistance. (See Figure 36)

IMPORTANT: Photo eyes are used as a safety feature and not as a door opener. Never try to interrupt either set of photo eyes as the door is closing. Wait for the door to perform its normal cycle before entering or exiting doorway.

NOTE: The Pathwach LED's are preinstalled in the side columns at the factory with the cables labeled, coiled, pre-routed to the side column top, and through the grommet. Be sure to route cables away from all moving parts. Use cable ties as required.

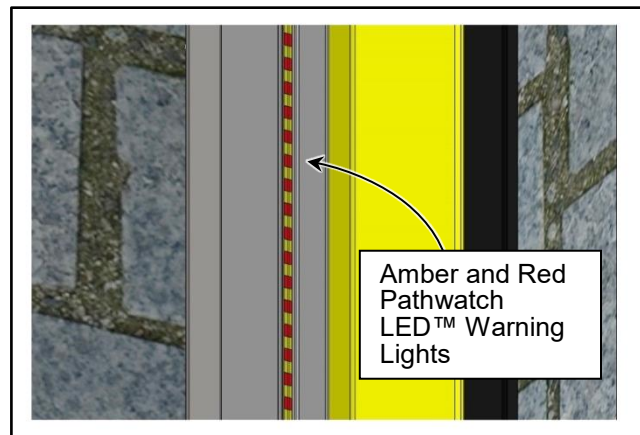

Figure 36

INSTALLATION-PATHWATCH LED™ WARNING LIGHTS

Front

1. Find and identify the Pathwatch LED warning light cables/wires in the side columns, both front and rear. They should be coiled & labeled at the top and pre-routed through the side column's wire chases.
2. After the side columns and head assembly have been assembled and mounted to the wall, confirm the front Pathwatch LED Warning light cables/wires are routed as shown in Figure 19, Figure 37, and Figure 38:
 - a. Through the wire chase on the inside front of the side column and down to the bottom. (See Figure 37)
 - b. Flat across the side column bottom back to the rear of the side column. Make sure the cables counterweight or crush plate. (See Figure 37)
 - c. Up the side column rear wire chase through the grommet and inside wire chase slot. (See Figure 19)
 - d. Up through the gap between the head assembly rear spreader and the wall. (See Figure 38)
3. Secure cables/wires with plastic ties to the rear spreader of the head assembly.
4. Connect cables/wires to junction box per schematic.

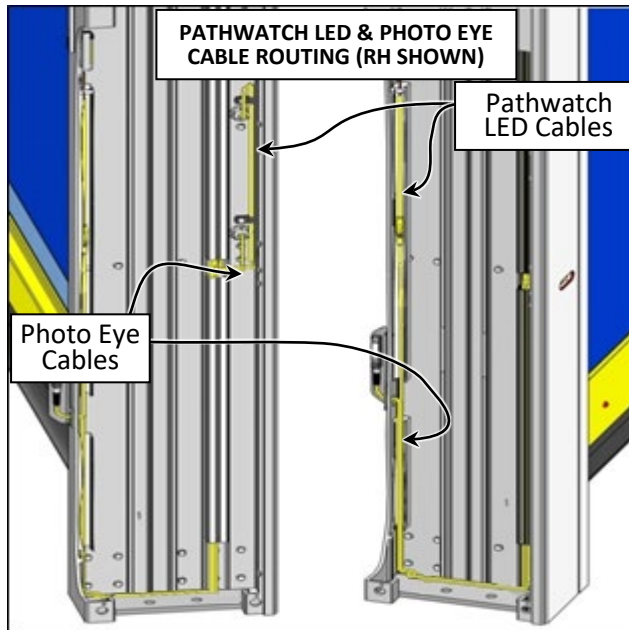

Figure 37

Rear

1. Find and identify the rear Pathwatch LED warning light cables/wires in the side columns. They should be coiled & labeled at the top and pre-routed through the side column's wire chases.
 2. After the side columns and head assembly have been assembled and mounted to the wall, confirm the rear Pathwatch LED Warning light cables/wires are routed as shown in Figure 19, Figure 37, and Figure 38:
 - a. Up the side column rear wire chase through the grommet and inside wire chase slot. (See Figure 19 and Figure 37)
 - b. Through the gap between the head assembly rear spreader and the wall and to the junction box. (See Figure 38)
- NOTE: Use the rear spreader of the head assembly to route the cables/wires to the junction box.*
3. Secure cables/wires with plastic ties to the rear spreader of the head assembly. (See Figure 38)
 4. Connect cable to junction box per schematic.

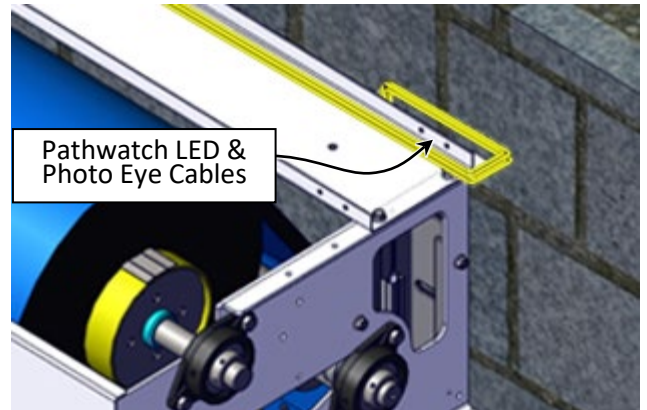

Figure 38

INSTALLATION-PHOTO EYES

PHOTO EYES

NOTE: The Photo eyes are an optional feature.

The photo eyes are provided as a safety feature. If the photo eyes are correctly installed, interrupting either set of eyes as the door is closing will reverse the direction of the door and hold it in the fully open position until the interruption is removed.

The transmitter and receiver can be identified in two ways. The transmitter is designated SMT 3000 on the white label or by a single green light that comes on at the clear end of the transmitter. (See Figure 39) The receiver is designated SMR 3215 on the white label or by a yellow light that illuminates only when it is in proper alignment with the transmitter. (See Figure 40)

NOTE: When the cable is connected to the photo eye, there is only a $\frac{1}{4}$ -inch window to see the green or yellow LED light.

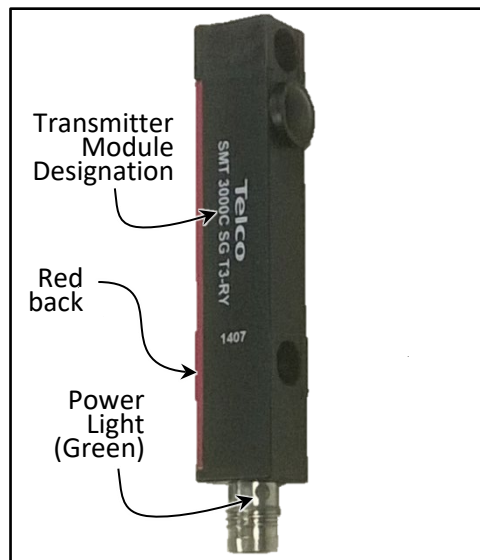

Figure 39

Front

1. The front photo eyes are externally mounted on the front of the side column. Check that the photo eye and all connections are secure and there is nothing damaged.
2. Confirm the front cable/wires are routed as shown in Figure 19, Figure 37, and Figure 38:
 - a. From the photo eye back into the side column, down the front side wire chase of the side column to the bottom. (See Figure 37)
 - b. Flat across the bottom of the side column back to the rear side column. Make sure the cables are flat on the bottom and don't interfere w/ the counterweight or crush plate. (See Figure 37)

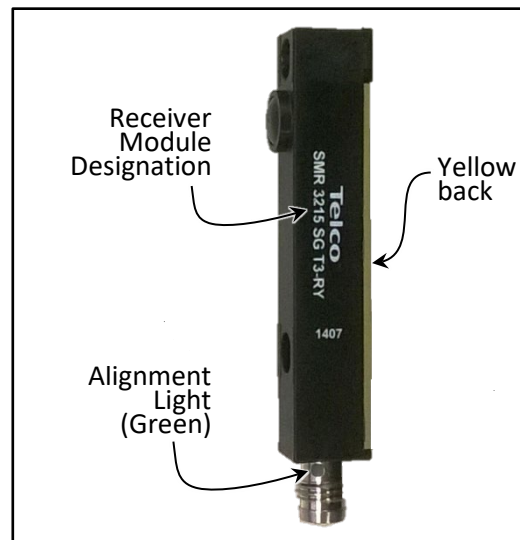

Figure 40

- c. Up the side column rear wire chase through the grommet and inside wire chase slot. (See Figure 19)
- d. Through the gap between the head assembly rear spreader and the wall to the rear junction box. (See Figure 38)

NOTE: Use the rear spreader of the head assembly to route the cables/wires to the junction box from the non-motor side.

3. Secure cables/wires with plastic ties to the rear spreader of the head assembly. (See Figure 38)
4. Connect cables/wires to junction box per schematic.

Rear

1. The rear photo eyes are internally mounted in the rear of the side column. Check that the photo eye and all connections are secure and there is nothing damaged.
2. Confirm the rear cable/wires are routed as shown in Figure 19, Figure 37, and Figure 38:
 - a. Up the side column rear wire chase through the grommet and inside wire chase slot. (See Figure 19, and Figure 37)
 - b. Through the gap between the head assembly rear spreader and the wall to the rear junction box. (See Figure 38)

NOTE: Use the rear spreader of the head assembly to route the cables/wires to the junction box from the non-motor side.

3. Secure cable with plastic ties to the rear spreader of the head assembly. (See Figure 38)
4. Connect cable/wires to junction box per schematic.

INSTALLATION-AIR BLOWER (DOOR OPENING HT ≤ 16 FT)

Testing Photo Eyes

With the power on, the green light on the transmitter indicates the photo eye module is powered up. When the yellow light on the receiver module is also lit, the transmitter and receiver modules are properly aligned.

Placing your hand in front of the receiver breaks the light path causing the yellow light to go out. Removing your hand causes the yellow light to go back on.

AIR BLOWER (DOOR OPENING HT ≤ 16 FT)

The Air Blower is an optional item providing frost prevention and buildup. Door openings that are 16 ft high or less utilize this style/model blower.

NOTE: Hardware is located in the small parts carton.

1. Locate and gather all the items in Figure 46. Install each air blower to the UNI-Strut Beam using (2) 3/8-16 x 1.25 in. long hex flange serrated machine screws, Ø3/8 in. flat washers, and 3/8-16 UNI-Strut nuts. Tighten fasteners. Orient the blower(s) with the air intake facing away from the door as shown (See Figure 41)

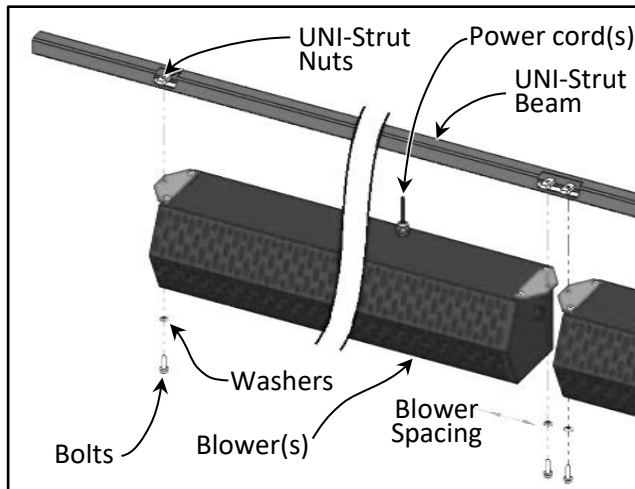

Figure 41

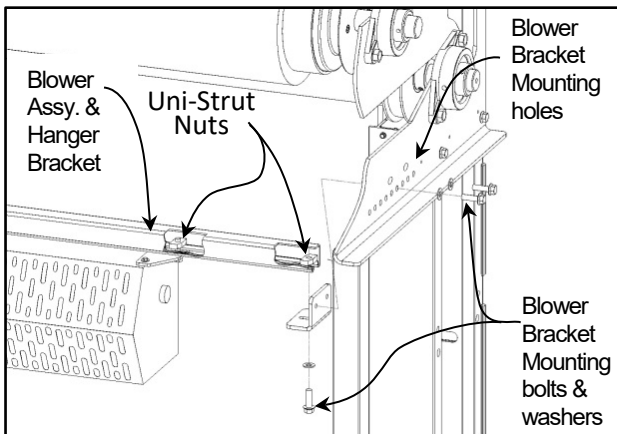

Figure 42

2. Install the blower mounting brackets to the head assembly with (4) 3/8-16 x 1.25 long Hex Flanged Socket Screws and 3/8 Flat Washers. Both brackets must be aligned and use the same mounting holes on each side of the head assembly mounting plates. (See Figure 41)
3. Mount the Air Blower Assembly to the Door Head Assembly. Place the UNI-Strut Beam on the Blower Assembly Mounting brackets and secure with (2) 3/8-16 x 1.25 long Hex Flanged Socket Screws and 3/8 Flat Washers into the 3/8-16 UNI-Strut nuts. (See Figure 42)
4. Space the blower(s) so that when mounted to the head assembly they are evenly spaced along the door width. Loosen fasteners and adjust as required. Tighten all fasteners securing the Blower Assembly and brackets in place. (See Figure 43)

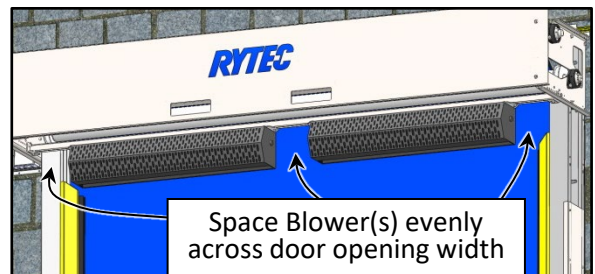

Figure 43

5. Route the Blower electrical power cord(s)/ wiring along the UNI-Strut Blower support located behind the front panel of the head assembly. Run cord(s) to the door side where the power supply junction box and control panel are located. Secure the cord(s) to the UNI-Strut with zip ties or equal. (See Figure 44)

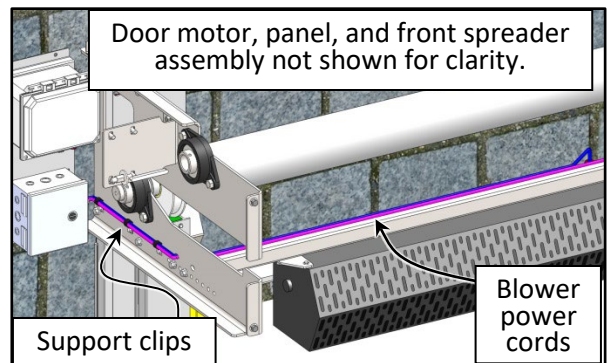

Figure 44

6. Route the Blower electrical power cord(s)/ wiring to the junction box through the Head Assembly door side mounting plate as shown. Use the side clips for support as shown. (See Figure 44)
7. Connect cable/wires to junction box per electrical schematic.
8. Test the airflow pattern of the blower(s) and make adjustments as necessary to achieve the best airflow coverage.

INSTALLATION-SIDE COLUMN HEATED BLOWER

SIDE COLUMN HEATED BLOWER

NOTE: The Heated blowers are an optional feature.

The Side Column Heated Blowers are to be installed in the bottom of each side column. They are RH/LH specific, and are **not interchangeable**. Warm air is generated and blown/circulated through the internal side column cavity by the blower and is controlled with a thermostat. (See Figure 45 - Figure 47)

NOTE: Heated blowers are shipped loose and holes are pre-cut in side columns.

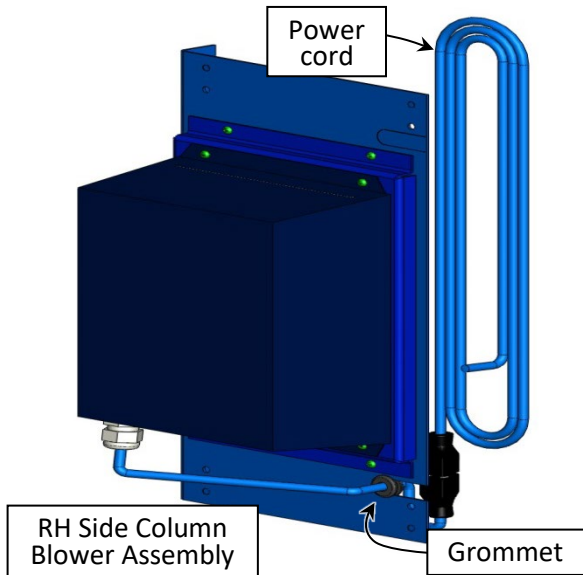

Figure 45

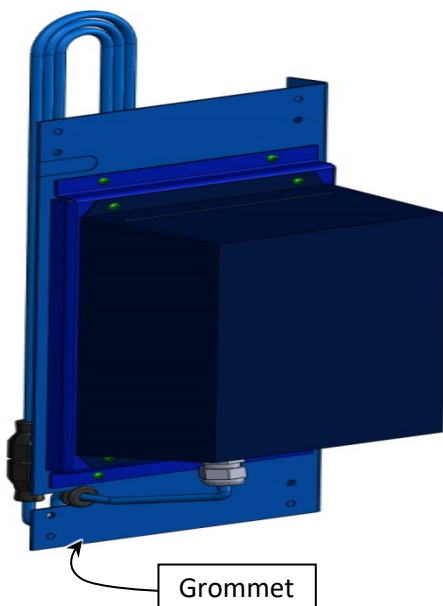

Figure 46

1. Locate and gather all the items in Figure 45/46 along w/ #12-24 x 1/2 Long Hex Flanged machine screws.

2. Remove side column covers.

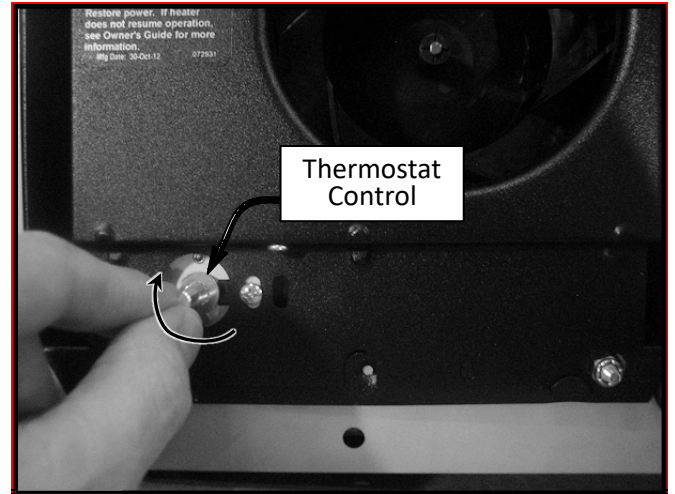

Figure 47

3. Route the wire end of the Power cord with the female receptacle to the power supply junction box for each side column heated blower as follows:
 - a. Run the power cord through the rear/outside wire chase in the side column from the bottom up to the top. (See Figure 48)
 - b. Run the cord out the top between the wall and the Head Assembly rear spreader. (See Figure 48)

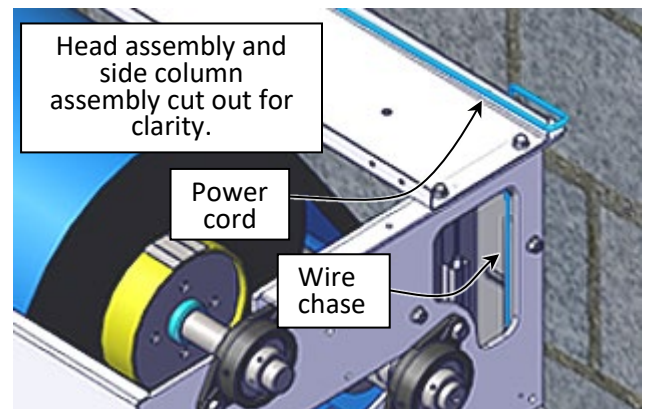

Figure 48

- c. Run the cord to the power connection junction box. Route the cord along the rear spreader as necessary securing with zip ties or equal.
 - d. Leave enough loose cord in the bottom of the side column to allow for connecting and installation/removal of the heated blower assembly.
4. Connect the power cords to the electrical leads in the junction box per electrical schematic. Install all side column covers.
 5. Confirm that the blower assembly power cords are routed through the mounting plate/grommet as shown. If not, do so. (See Figure 45 and Figure 46)

INSTALLATION-SIDE COLUMN HEATED BLOWER

6. Connect the female and male blower power cords on respective sides. Arrange the blower power cords so there won't be any interference with the function of any parts such as the counterweight, crush plate, etc.
7. Turn the thermostat control dial clockwise completely to set the blower heat to high. (See Figure 47)

IMPORTANT: The Side Column Heater Thermostat must be set to its highest setting to operate properly. Failure to do so may result in ice buildup or other related issues.

8. Orient blowers as shown. Install in the Side Column Assemblies. Use (4) #12-24 x ½ in. long hex flange serrated machine screws for each one. Tighten fasteners. (See Figure 49 and Figure 50)
9. Turn on the electrical supply.

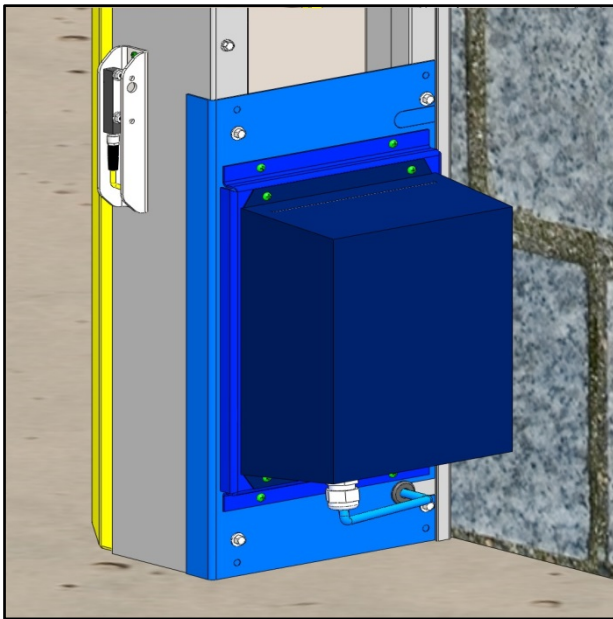

Figure 49

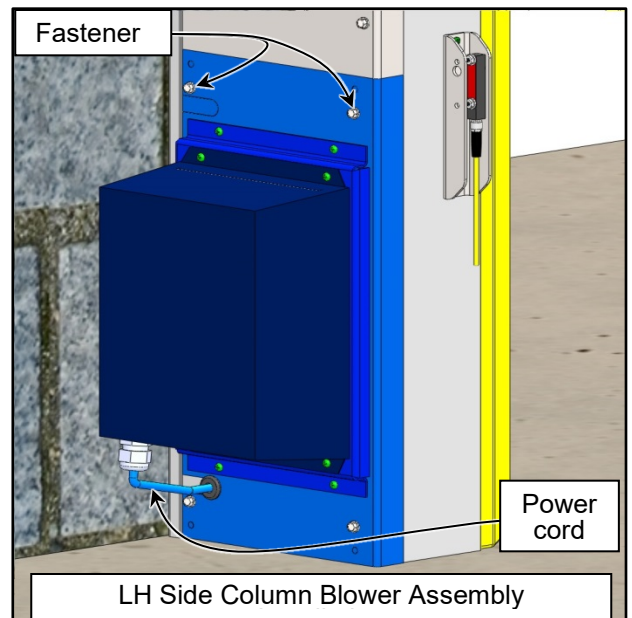

Figure 50

NOTE: The fan for the side column heaters must be rotating for the defrost system to work properly. During shipment the fan may bind against the casing. If the fan is not turning, rotate the fan on the shaft and the fan should begin to turn. If not, check for proper voltage to the fan and contact Rytec Technical Support for assistance at 1-800-628-1909.

After 30 minutes the surface of the heater housing should be warm to the touch and frost should begin to dissipate. Please contact Rytec Technical Support at 1-800-628-1909 with any questions.

FINAL CHECKS-CLEAR SIDE COLUMN TOP COVERS

CLEAR SIDE COLUMN TOP COVERS

The side columns have a transparent cover that gets mounted at the very top just below the Head or Blower Assembly.

1. Locate the Clear-transparent Top Side Column Cover. It should be in the Small Parts Container.
2. Remove the covering film from the Top Side Column Covers.
3. Mount the covers on each Side Column as shown. (See Figure 51 & Figure 52)

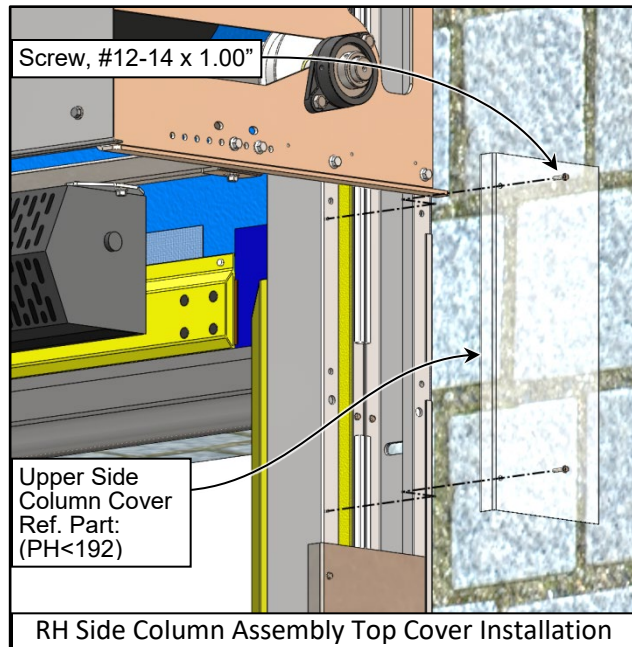

Figure 51

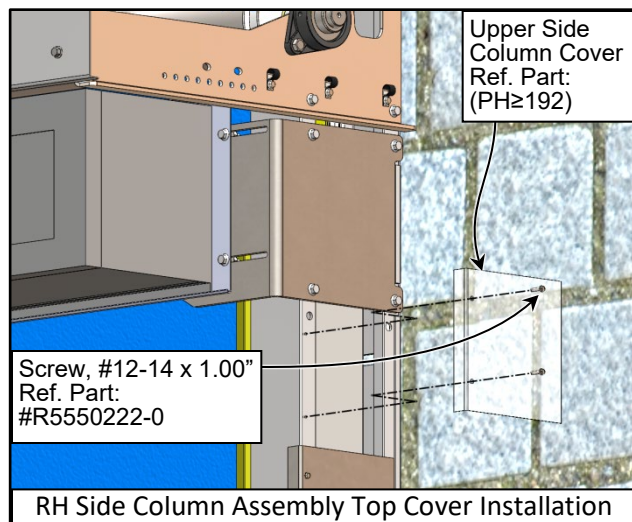

Figure 52

FINAL CHECKS

NOTE: Check all of the following door components and systems once the door panel has been cycled at least 20 times.

Side Columns: Check that side columns are plumb and square and that all anchor bolts are secure and tight.

Head Assembly: Check that all mounting hardware is in place and tight.

Bottom Bar: Check that the bottom bar travels smoothly up and down within the side columns. Also check that the breakaway/self repair feature works properly as described in the “RESETTING BOTTOM BAR” section on page 13.

Limit Positions: Adjusted properly. Up and down travel of the door should be as described in “DOOR OPEN- AND CLOSE-LIMIT POSITIONS” on pages 12 and 12.

Motor: Check that the door travels in the proper direction when the button is pressed.

Reversing Edge (optional): Works properly. As the door is closing, if the reversing edge makes contact with an object, the door should immediately return to the fully open position as described in “REVERSING EDGE SWITCH INSPECTION AND ADJUSTMENT” on page 12.

Timers: Automatic timers must be set to ensure that the door closes properly, as described in the Rytec System 4 Drive & Control Installation & Owner’s Manual.

Activators: Operate as specified by manufacturer.

Caulk: Ensure that the side columns and head assembly are caulked where they meet the wall of the building.

Photo Eyes (optional): Make sure the photo eyes are working as described in “DAILY INSPECTION” in the Owner’s Manual.

Defrost System (optional): Make sure the blowers are adjusted and operating properly.

